



United Technologies
turn to the experts 

Package Rooftop Units – 50Hz



Quality Assurance
Certificate Reg. No:
04 100 950420



Subject to change without notice
Manufacturing point: Jeddah, Saudi Arabia
Nearest port of embarkation: Jeddah Islamic port
Product classification: Commercial

Product Data Catalog

50TCM – 50Hz **Nominal Cooling Capacity 6 – 12.5 Tons** **HFC R-410A Refrigerant**

The 50TCM units are single side discharge rooftop cooling unit utilizing electric heat as an option. Units are pre-wired, pre-charged with R-410A refrigerant, and tested at the factory. These units can be placed on the side of a building or can be placed on a roof without roof curbs. Each unit is designed to occupy a minimal space. Piping and drain connections are readily accessible.

Contact your local Carrier representative for additional reference materials.

Table of Contents

Features / Benefits.....	2
Shipping Information / Options / Accessories.....	4
Model No. Nomenclature.....	6
AHRI Capacity Ratings.....	7
Physical Data.....	8
Unit Dimensional Drawing.....	10
Cooling Capacities.....	16
Fan Performance Table.....	21
Fan RPM at Motor Pulley / Sound Rating.....	24
Electrical Data / Electric Heater Data.....	25
Wiring Schematic.....	27
Application Data.....	32
Guide Specifications.....	33

Features / Benefits

Every compact one-piece unit arrives fully assembled, charged, tested, and ready to run.

Durable-Dependable Construction

Designed for durability in any climate, the weather-resistant cabinets are constructed of galvanized steel, bonderized, and all exterior panels are coated with a pre-painted baked enamel finish. The paint finish is non-chalking, and is capable of withstanding ASTM (American Society for Testing and Materials) B117 500-hour Salt Spray Test. All internal cabinet panels are primed, permitting longer life and a more attractive appearance for the entire unit. Totally enclosed condenser-fan motor and permanently lubricated bearings provide additional unit dependability.

Indoor-Air Quality

Non corrosive sloped condensate pans minimize biological growth in rooftop units in accordance with ASHRAE (American Society of Heating, Refrigeration and Air Conditioning Engineers) Standard 62-99 (IAQ). 2"inch filters provide for greater particle reduction in the return air.

Simple, Electrical Connections

Terminal boards, located in the unit control box, facilitate connections to room thermostat, outdoor thermostat(s) and electric heater. Service panels can be quickly removed, permitting easy servicing. Both power and control connections are made on the same side of the unit to simplify installation. In addition, color-coded wires permit easy tracing and diagnostics.

Easy Installation

All units feature base rail design with forklift slots and rigging holes for easier maneuvering. Durable packaging protects all units during shipment and storage. Convenient side by side openings permit installation very close to face of buildings or on roof top. The non-corrosive sloped condensate pan minimizes residual condensate in off cycle. An external, field-supplied P-trap is required. Field-installed electric heaters are available up to 34.7 kW.

Installation Features

- Single point electrical service entry
- Side discharge application
- No roof curb needed
- Side-by-side supply and return air
- Separate panel for control box

Performance Features

- HFC R-410A non-ozone depleting refrigerant
- ASHRAE Compliant
- EER's up to 12.5
- TXV refrigerant metering device
- Two independent refrigerant circuits, each with a scroll compressor
- Low outdoor temperature cooling operation down to 40° F
- Liquid filter drier standard on each circuit
- Fresh air intake capable
- Non-corrosive sloped condensate drain pan in accordance to ASHRAE 62 standard
- Thermally protected and permanently lubricated condenser and evaporator fan motors
- Angle type return air section with washable type filters

Environmentally Sound Refrigerant Choice

R410A refrigerant is:

- A chlorine-free refrigerant from the HFC group
- Has zero ozone depletion potential
- Thermally efficient and provides high EER (energy efficiency), COP, and part load efficiencies

Superior Reliability, Efficiency and Safety

- Exceptional endurance tests
 - Painted panels tested to ASTM B-117 500 hours salt spray protection
 - Pre-coated fin condenser coil for extra corrosion protection
- Compressor Protection:
 - High and low pressure cutouts
 - Phase protection relay
 - Crankcase heaters are standard for all units
 - Internal over temperature protection
 - Freeze protection
- Low vibration design:
 - Leak-tight refrigerant circuit
 - Brazed refrigerant connections for increased leak tightness
 - Low-noise scroll compressors with low vibration levels
- Control circuit protected by circuit breaker
- Thermally protected and permanently lubricated condenser and evaporator fan motors
- Angle type return air section with washable type filters
- Transformer for safe 24V control circuit supply included
- High Efficiency, High Static Blower
- State-of-art scroll compressor technology
- Dual, electrically and mechanically independent refrigerant circuit
- Double skin construction, insulated cabinet

Shipping Information

Unit data with Condenser and Evaporator Al/Cu Coils¹

Unit Model Number	EST. WT. (KG)		DIMENSIONS (MM)					
			Net			With Wooden create above		
	NET	GROSS (with Skid)	LENGTH	WIDTH	DEPTH	LENGTH	WIDTH	DEPTH
50TCMA07AXA1-0A0A0	275	285	1051	1888	1187	1089	1943	1219
50TCMD08AXA1-0A0A0	345	360	1048	2238	1510	1207	2292	1543
50TCMD09AXA1-0A0A0	388	403	1253	2238	1510	1412	2292	1543
50TCMD12AXA1-0A0A0	393	408	1253	2238	1510	1412	2292	1543
50TCMD14AXA1-0A0A0	489	504	1253	2238	1510	1412	2292	1543

Unit data with Condenser Only Cu/Cu Coils

Unit Model Number	EST. WT. (KG)		DIMENSIONS (MM)					
			Net			With Wooden create above		
	NET	GROSS (with Skid)	LENGTH	WIDTH	DEPTH	LENGTH	WIDTH	DEPTH
50TCMA07AEA1-0A0A0	310	320	1051	1888	1187	1089	1943	1219
50TCMD08AEA1-0A0A0	379	394	1048	2238	1510	1207	2292	1543
50TCMD09AEA1-0A0A0	430	445	1253	2238	1510	1412	2292	1543
50TCMD12AEA1-0A0A0	434	449	1253	2238	1510	1412	2292	1543
50TCMD14AEA1-0A0A0	530	545	1253	2238	1510	1412	2292	1543

Unit data with Condenser and Evaporator Cu/Cu Coils

Unit Model Number	EST. WT. (KG)		DIMENSIONS (MM)					
			Net			With Wooden create above		
	NET	GROSS (with Skid)	LENGTH	WIDTH	DEPTH	LENGTH	WIDTH	DEPTH
50TCMA07AFA1-0A0A0	331	341	1051	1888	1187	1089	1943	1219
50TCMD08AFA1-0A0A0	398	413	1048	2238	1510	1207	2292	1543
50TCMD09AFA1-0A0A0	461	476	1253	2238	1510	1412	2292	1543
50TCMD12AFA1-0A0A0	465	480	1253	2238	1510	1412	2292	1543
50TCMD14AFA1-0A0A0	561	576	1253	2238	1510	1412	2292	1543

Factory Installed Options and Field Installed Accessories

Category	Item Description	Factory Installed Option	Field Installed Accessory
Coil Options	Cu/Cu indoor and/or outdoor coils	X	
	Pre-coated outdoor coils	X	
Condenser Protection	Condenser coil hail guard (louvered design)		X
Controls	Thermostats, temperature sensors, and subbases		X
	PremierLink DDC communicating controller		X
	RTU Open –protocol controller		X
	Time Guard II compressor delay control circuit		X
	Smoke detector (supply and return)		X
Electric Heat	Electric Resistance Heaters		X
	Single Point Kit		X
Indoor Motor & Drive	Multiple motor and drive packages	X	
Low Ambient Control	Winter start kit ²		X
	Motormaster head pressure control		X

NOTES:

1. Please refer to product nomenclature for ordering information.
2. See application data for assistance.

Factory Options and Accessories

RTU Open, Multi-protocol Controller

Connect the rooftop to an existing BAS without complicated translators or adapter modules using the RTU Open controller. This new controller speaks the 4 most common building automation system languages (BACNET, Modbus, Johnson N2, and LonWorks). Use this controller when you have an existing BAS.

PremierLink

This CCN controller regulates your rooftop's performance to tighter tolerances and expanded limits, as well as facilitates zoning systems and digital accessories. It also unites your Carrier HVAC equipment together on one, coherent CCN network. The PremierLink can be factory-installed, or easily field-installed.

Time Guard II Control Circuit

This accessory protects your compressor by preventing short-cycling in the event of some other failure, prevents the compressor from restarting for 30 seconds after stopping. Not required with PremierLink, RTU Open, or authorized commercial thermostats.

Filter or Fan Status Switches

Use these differential pressure switches to detect a filter clog or indoor fan motor failure. When used in conjunction with a compatible unit controller/thermostat, the switches will activate an alarm to warn the appropriate personnel.

Winter Start Kit

The winter start kit by Carrier extends the low ambient limit of your rooftop to 25°F (-4°C). The kit by-passes the low pressure switch, preventing nuisance tripping of the low pressure switch. Other low ambient precautions may still be prudent.

Alternate Motors and Drives

Some applications need larger horsepower motors, some need more airflow, and some need both. Regardless of the case, your Carrier expert has a factory installed combination to meet your application. A wide selection of motors and pulleys (drives) are available, factory installed, to handle nearly any application.

Electric Heaters

Carrier offers a full-line of field-installed accessory heaters. The heaters are very easy to use, install and are all pre-engineered and certified.



Model Number Nomenclature - 50TCM - R410A Series

1	2	3	4	5	6	7	8	9	10	11	12	13	14	15	16	17	18
5	0	T	C	M	A	0	7	A	9	A	1	-	0	A	0	A	0

Unit Heat Type
50 = Cooling /
Electric Heat RTU

Model Series - Desert Master
TCM = High Ambient Application

Refig. System Options
A = Standard 1 - Stage Cooling
D = Standard 2 - Stage Cooling Models 08-14

Nominal Ton
07 = 6 Ton
08 = 7.5 Ton
09 = 8.5 Ton
12 = 10 Ton
14 = 12.5 Ton

Sensor Options
A = None

Power Supply (V/Ph/Hz)
9 = 400/3/50

Brand/Packaging
0 = Standard

Electrical Options
A = None

Service Options
0 = None

Intake / Exhaust Options
A = None

Base Unit Controls
0 = Electromechanical Controller
1 = RTU Open Controller

Design Review
- = Factory Assigned

Indoor Fan Options
1 = Standard Static Option
2 = Medium Static Option
3 = High Static Option

Coil Options (Outdoor - Indoor)
A = Al/Cu - Al/Cu
B = Precoat Al/Cu - Al/Cu
E = Cu/Cu - Al/Cu
F = Cu/Cu - Cu/Cu

AHRI Capacity Rating

Unit 50TCM	Nominal Ton	Standard CFM	Net Cooling Capacity (BTU/hr)	Net Cooling Capacity (Watt)	Net Cooling Capacity (Ton)	EER	Standard m3/hr	Standard L/s
A07	6.0	2400	66500	19496	5.5	11.2	4075	1133
D08	7.5	3000	86500	25359	7.2	12.5	5094	1416
D09	8.5	3400	94000	27558	7.8	11.9	5773	1604
D12	10.0	4000	113500	33274	9.5	11.5	6792	1888
D14	12.5	4800	135500	39724	11.3	11.0	8150	2265

Minimum - Maximum Air Flow Rate

Unit 50TCM	Minimum	Maximum	Minimum	Maximum
	CFM	CFM	L/s	L/s
A07	1800	2850	849	1345
D08	2250	3750	1062	1770
D09	2550	4250	1203	2006
D12	3000	4500	1416	2124
D14	3700	5700	1746	2690

Minimum Electric Heating Air Flow Rate

Unit 50TCM	Unit Voltage	Heater kW	Unit Configuration	Minimum	Minimum
				CFM	L/s
A07	400	All	Horizontal	1800	849
D08	400	All	Horizontal	2250	1062
D09	400	All	Horizontal	2250	1062
D12	400	All	Horizontal	3000	1416
D14	400	All	Horizontal	3000	1416

EER - Energy Efficiency Ratio

CFM - Cubic Feet per Minute

L/s - Liters per Second

BTU - British Thermal Unit

*AHRI - Air Conditioning, Heating and Refrigeration Institute.

1. Rated in accordance with AHRI Standards 340/360.
2. Ratings are net values, reflecting the effects of circulating fan heat.
3. Cooling Standard: 80 F db, 67 wb indoor entering-air temperature and 95 F db air entering outdoor unit.

Unit Physical Data (English)



Unit 50TCM	A07	D08	D09	D12	D14
Unit Dimensions	41.3x74.3x46.7	41.2x88.1x59.4	49.3x88.1x59.4		
Unit Operating Weight	606	761	855	866	1078
Refrigeration System					
Compressor No.# / Type	1 / Scroll		2 / Scroll		
Refrigerant type	Puron ® R410A				
Circuits No.#	1	2			
Charge per Circuit (1-Down/2-Up) -LBS	16.20	8.71/8.82	9.48/9.92	10.65/10.63	12.79/12.24
Metering Device	Acutrol				
Filter Drier Qty	1	2			
High Pressure Switch (Trip/ Reset)- PSIG	630 / 505				
Low Pressure Switch (Trip/ Reset)- PSIG	54 / 117				
Condenser Coil *					
Coil Type	3/8" helical grooved copper tube, 0.75" Aluminum LSW fins.				
Standard Coil Material	Cu/Al				
Rows / FPI	2 / 17		1 / 20	2 / 20	
Face Area (ft ²)	21.3	20.5	25.1		
Coil test Pressure (PSIG)	450				
Condenser Fan & Motor					
Approx. Air Flow Rate (CFM)	5000	6400	7800	7500	7000
Quantity	1	2		1	
Diameter (in) / No. of Blades	26/3	22/3		30/4	
Motor Type	Induction Motor - Totally Enclosed				
Motor HP - RPM	1/3-960	1/3-1200		1-950	
Evaporator Coil *					
Coil Type	3/8" helical grooved copper tube, 0.75" Aluminum LSW fins.				
Standard Coil Material	Cu/Al				
Rows / FPI	4/15	3/15	4/15		
Face Area (ft ²)	7.3	8.9	11.1		
Coil test Pressure (PSIG)	350				
Drain Pan connection Size (in)	3/4				
Return Air Filter Qty/ Size (in)	4 / 16x16x2	4 / 16x20x2	4 / 20x20x2		
Evaporator Fan & Motor section					
Fan Quantity / Fan Size (in)	1 / 10 x 10		1 / 15 x 15		
Fan Type	Centrifugal - Forward Blade				
Drive Type	Belt				
Motor Type	Induction Motor - TEFC				
Standard Static Drive					
Motor Qty	1				
Maximum BHP	1.4	2		2.4	
FLA	2.6		3.4		3.4
Efficiency @ Full Load	80%		81%		
RPM Range	855-1211	570-808		665-903	
Shaft Diameter (in)	5/8		7/8		
Motor Frame Size	56Y				
Medium Static Drive					
Motor Qty	1				
Maximum BHP	2.4		3.1	3.9	
FLA	3.4		4.4	7.4	
Efficiency @ Full Load	81%				
RPM Range	1077-1393	692-896		808-1040	837-1015
Shaft Diameter (in)	7/8				
Motor Frame Size	56Y		56HZ	145TY	
High Static Drive					
Motor Qty	1				
Maximum BHP	3.1	3.9		4.2	
FLA	4.4	7.4		9.8	
Efficiency @ Full Load	81%				
RPM Range	1211-1568	881-1140		957-1160	
Shaft Diameter (in)	7/8		1 1/8		1 1/8
Motor Frame Size	56HZ	145TY		S184T	

Unit Physical Data (SI)

Unit 50TCM	A07	D08	D09	D12	D14
Unit Dimensions	1051x1888x1187	1048x2238x1510	1253x2238x1510		
Unit Operating Weight	275	345	388	393	489
Refrigeration System					
Compressor No.# / Type	1 / Scroll		2 / Scroll		
Refrigerant type	Puron ® R410A				
Circuits No.#	1	2			
Charge per Circuit (1-Down/2-Up) - kG	7.35	3.95 / 4.00	4.30 / 4.50	4.83 / 4.82	5.80 / 5.55
Metering Device	Acutrol				
Filter Drier Qty	1	2			
High Pressure Switch (Trip/ Reset) - bar	43 / 34				
Low Pressure Switch (Trip/ Reset) - bar	4 / 8				
Condenser Coil *					
Coil Type	3/8" helical grooved copper tube, 0.75" Aluminum LSW fins.				
Standard Coil Material	Cu / Al				
Rows / FPI	2 / 17		1 / 20	2 / 20	
Face Area (m ²)	1.98	1.90	2.33		
Coil test Pressure (bar)	31				
Condenser Fan & Motor					
Approx. Air Flow Rate (m ³ /hr)	8492.0	10867.2	13244.4	12735	11886
Quantity	1	2		1	
Diameter (mm) / No. of Blades	660 / 3	559 / 3		762 / 4	
Motor Type	Induction Motor - Totally Enclosed				
Motor HP - RPS	1/3-38	1/3 - 47		1-37	
Evaporator Coil *					
Coil Type	3/8" helical grooved copper tube, 0.75" Aluminum LSW fins.				
Standard Coil Material	Cu/Al				
Rows / FPI	4 / 15	3 / 15	4 / 15		
Face Area (m ²)	0.7	0.8	1.0		
Coil test Pressure (bar)	23.8				
Drain Pan Connection Size (mm)	19				
Return Air Filter Qty x Size (in)	4 / 16x16x2	4 / 16x20x2	4 / 20x20x2		
Evaporator Fan & Motor section					
Fan Quantity / Fan Size (mm)	1 / 254 x 254	1 / 381 x 381			
Fan Type	Centrifugal - Forward Blade				
Drive Type	Belt				
Motor Type	Induction Motor - TEFC				
Standard Static Drive					
Motor Qty	1				
Maximum kW	1.0	1.5		1.8	
FLA	2.6		3.4		3.4
Efficiency @ Full Load	80%				
RPS Range	14.3 - 20.2	9.5 - 13.5		11.1 - 15.1	
Shaft Diameter (mm)	15.9				
Motor Frame Size	56Y				
Medium Static Drive					
Motor Qty	1				
Maximum kW	1.8		2.3	2.9	
FLA	3.4		4.4	7.4	
Efficiency @ Full Load	81%				
RPS Range	18.0 - 23.2	11.5 - 14.9		13.5 - 17.3	14.0 - 16.9
Shaft Diameter (mm)	22.2				
Motor Frame Size	56Y		56HZ	145TY	
High Static Drive					
Motor Qty	1				
Maximum kW	2.3	2.9		3.1	
FLA	4.4	7.4		9.8	
Efficiency @ Full Load	81%				
RPS Range	20.2 - 26.1	14.7 - 19.0		16.0 - 19.3	
Shaft Diameter (mm)	22.2			28.5	
Motor Frame Size	56HZ	145TY		S184T	

CURBS & WEIGHTS DIMENSIONS - 50TCM07

NOTES:

1. DIMENSIONS ARE IN INCHES, DIMENSIONS IN () ARE IN MILLIMETERS.
2.  CENTER OF GRAVITY
3.  DIRECTION OF AIR FLOW

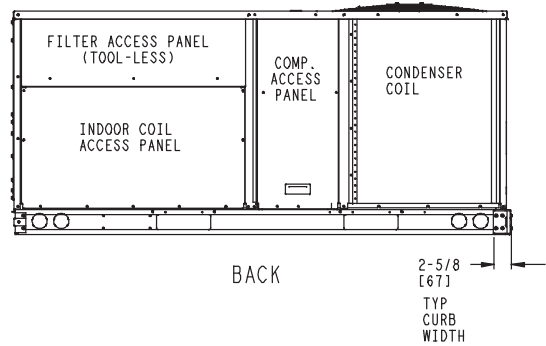
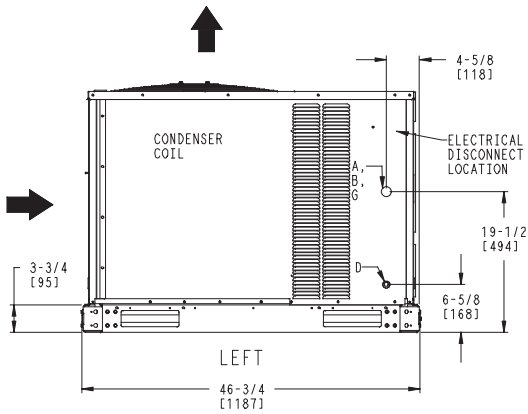
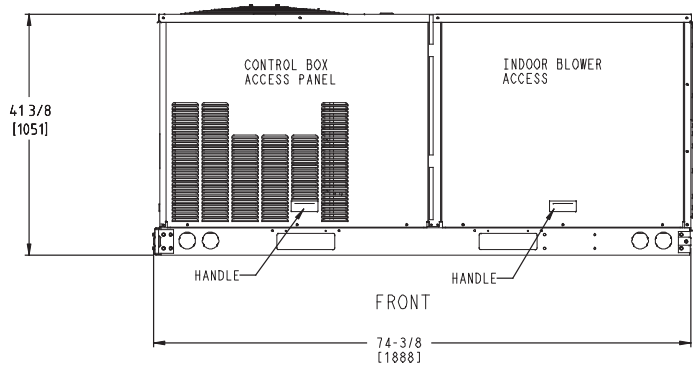
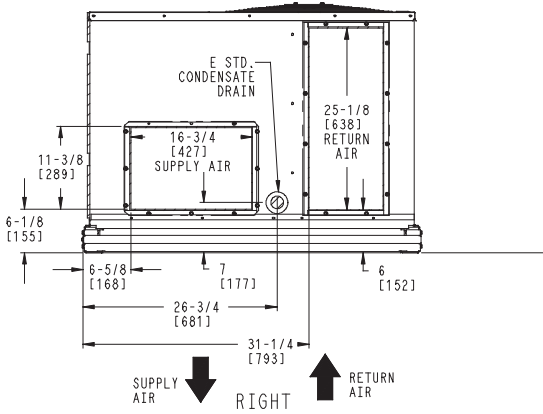
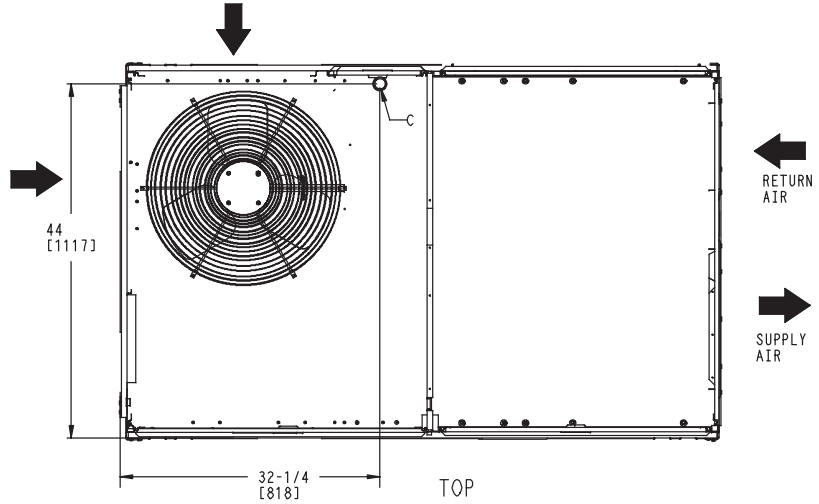

CONNECTION SIZES	
A	1 3/8" DIA [35] FIELD POWER SUPPLY HOLE
B	2" DIA [51] POWER SUPPLY KNOCKOUT
C	1 3/4" DIA [44] GAUGE ACCESS PLUG
D	7/8" DIA [22] FIELD CONTROL WIRING HOLE
E	3/4"-14 NPT CONDENSATE DRAIN
G	2 1/2" DIA [64] POWER SUPPLY KNOCK-OUT

Dimensions 50TCMA07

CURBS & WEIGHTS DIMENSIONS - 50TCM07 (cont.)

UNIT	STD. UNIT WEIGHT		CORNER WEIGHT (A)		CORNER WEIGHT (B)		CORNER WEIGHT (C)		CORNER WEIGHT (D)		C.G.		HEIGHT
	LBS.	KG.	LBS.	KG.	LBS.	KG.	LBS.	KG.	LBS.	KG.	X	Y	Z
50TCMA07	607	275	150	68	160	73	153	69	144	65	38 [965]	22 [559]	20 3/4 [527]

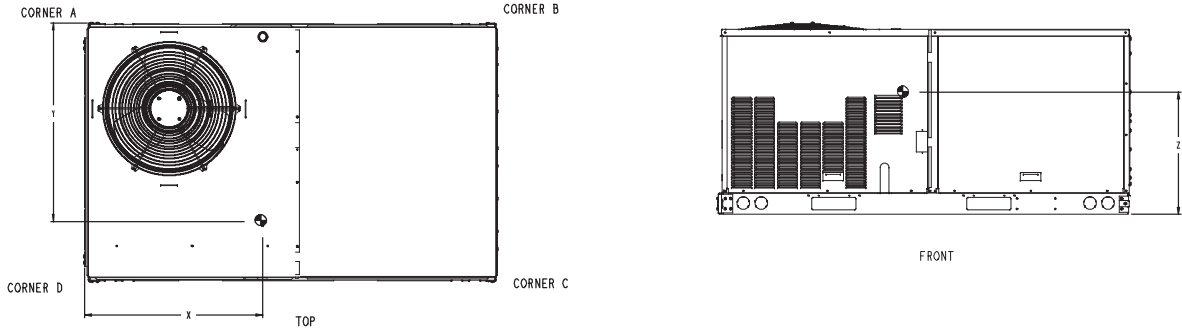

Dimensions 50TCMA07

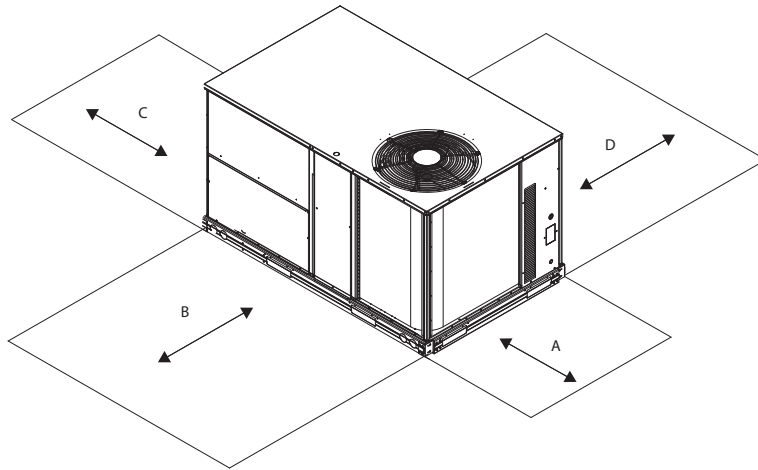

Service Clearance

LOC	DIMENSION	CONDITION
A	48-in (1219 mm) 18-in (457 mm) 18-in (457 mm) 12-in (305 mm)	Unit disconnect is mounted on panel No disconnect, convenience outlet option Recommended service clearance Minimum clearance
B	42-in (1067 mm) 36-in (914 mm) Special	Surface behind servicer is grounded (e.g., metal, masonry wall) Surface behind servicer is electrically non-conductive (e.g., wood, fiberglass) Check for sources of flue products within 10-ft of unit fresh air intake hood
C	36-in (914 mm) 18-in (457 mm)	Side condensate drain is used Minimum clearance
D	42-in (1067 mm) 36-in (914 mm)	Surface behind servicer is grounded (e.g., metal, masonry wall, another unit) Surface behind servicer is electrically non-conductive (e.g., wood, fiberglass)

CURBS & WEIGHTS DIMENSIONS - 50TCMD08/09

NOTES:

1. DIMENSIONS ARE IN INCHES, DIMENSIONS IN () ARE IN MILLIMETERS.

2. CENTER OF GRAVITY

3. DIRECTION OF AIR FLOW

CONNECTION SIZES	
A	1 3/8" DIA [35] FIELD POWER SUPPLY HOLE
B	2 1/2" [64] DIA POWER SUPPLY KNOCKOUT
C	1 3/4" DIA [51] GAUGE ACCESS PLUG
D	7/8" DIA [22] FIELD CONTROL WIRING HOLE
E	3/4"-14 NPT CONDENSATE DRAIN
G	2 " DIA [51] POWER SUPPLY KNOCK-OUT

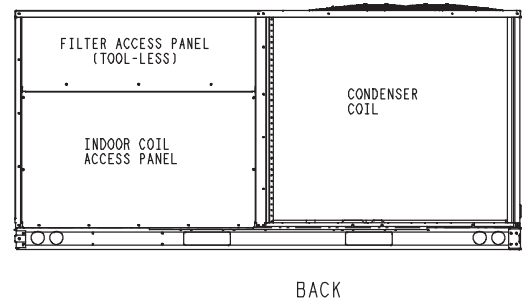
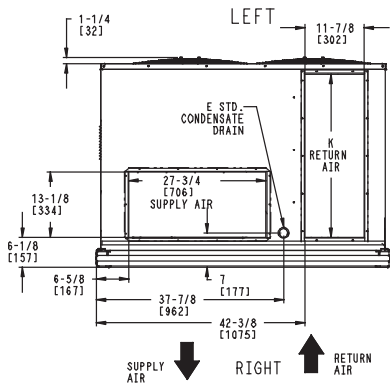
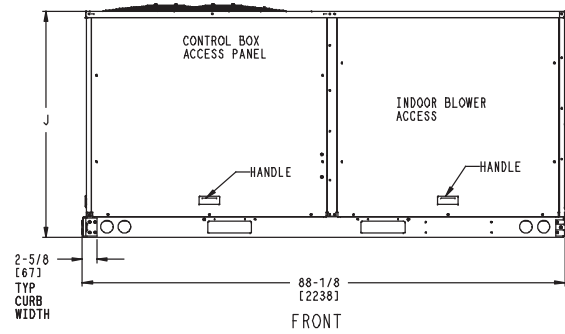
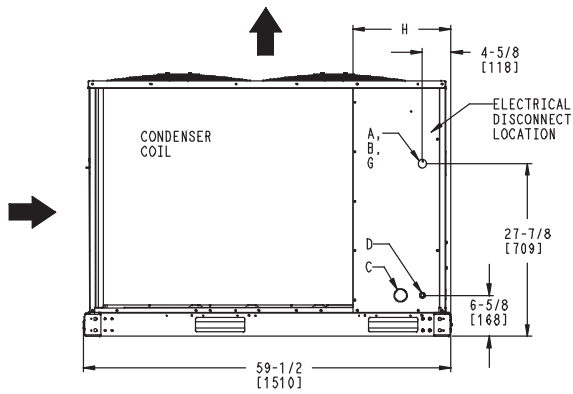
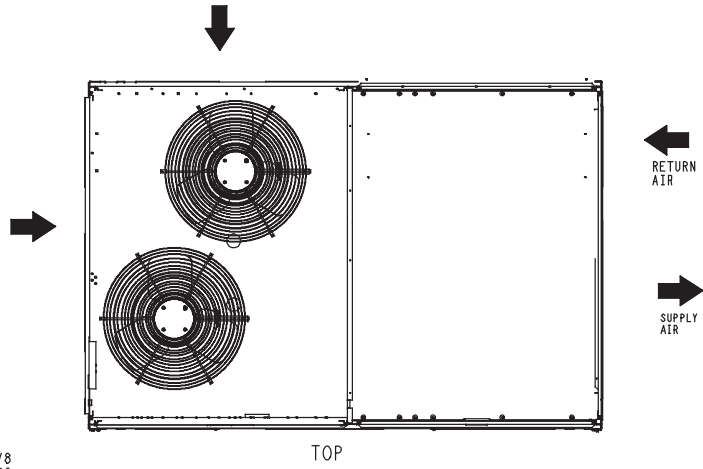

UNIT	OUTDOOR COIL TYPE	J	K	H
50TCMD08	RTPF	41 1/4 [1048]	33 [858]	15 7/8 [403]
50TCMD09	RTPF	49 3/8 [1253]	37 1/4 [946]	15 7/8 [403]

RTPF - ROUND TUBE, PLATE FIN (COPPER/ALUM)

Dimensions 50TCMD08/09

CURBS & WEIGHTS DIMENSIONS - 50TCMD08/09 (cont.)

UNIT	OUTDOOR COIL TYPE	STD. UNIT WEIGHT ***		CORNER WEIGHT (A)		CORNER WEIGHT (B)		CORNER WEIGHT (C)		CORNER WEIGHT (D)		C.G.		
		LBS.	KG.	LBS.	KG.	LBS.	KG.	LBS.	KG.	LBS.	KG.	X	Y	Z
50TCMD08	RTPF	760	345	158	71.7	155	70.4	222	100.8	225	102.2	43 3/4 [1111.3]	35 [889]	20 [508]
50TCMD09	RTPF	855	388.2	223	101.2	171	77.6	200	90.8	261	118.5	38 3/8 [975]	32 1/8 [816]	19 1/8 [486]
RTPF - ROUND TUBE, PLATE FIN (COPPER/ALUM)										*** STANDARD UNIT WEIGHT IS WITHOUT ELECTRIC HEAT AND WITHOUT PACKAGING. FOR OTHER OPTIONS AND ACCESSORIES, REFER TO THE PRODUCT DATA CATALOG.				

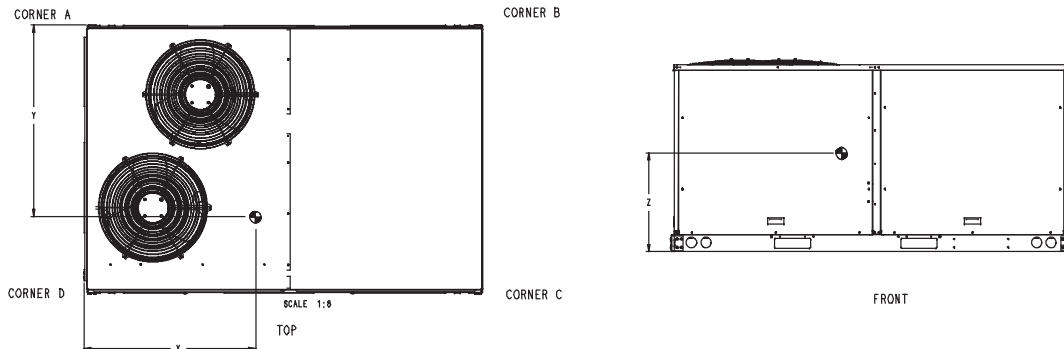

Dimensions 50TCMD08/09

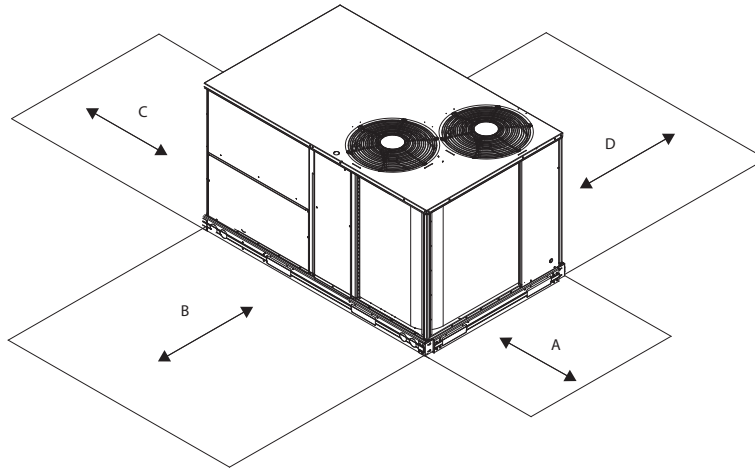

Service Clearance

LOC	DIMENSION	CONDITION
A	48-in (1219 mm)	Unit disconnect is mounted on panel
	36-in (914 mm)	If dimension-B is 12-in (305 mm)
	18-in (457 mm)	No disconnect, convenience outlet option
	18-in (457 mm)	Recommended service clearance (use electric screwdriver)
	12-in (305 mm)	Minimum clearance (use manual ratchet screwdriver)
B	12-in (305 mm)	If dimension-A is 36-in (914 mm)
	Special	Check for sources of flue products within 10-ft of unit fresh air intake hood
C	36-in (914 mm)	Side condensate drain is used
	18-in (457 mm)	Minimum clearance
D	42-in (1067 mm)	Surface behind servicer is grounded (e.g., metal, masonry wall, another unit)
	36-in (914 mm)	Surface behind servicer is electrically non-conductive (e.g., wood, fiberglass)

CURBS & WEIGHTS DIMENSIONS - 50TCMD12/14

NOTES:

1. DIMENSIONS ARE IN INCHES. DIMENSIONS IN () ARE IN MILLIMETERS.
2. CENTER OF GRAVITY
3. DIRECTION OF AIR FLOW

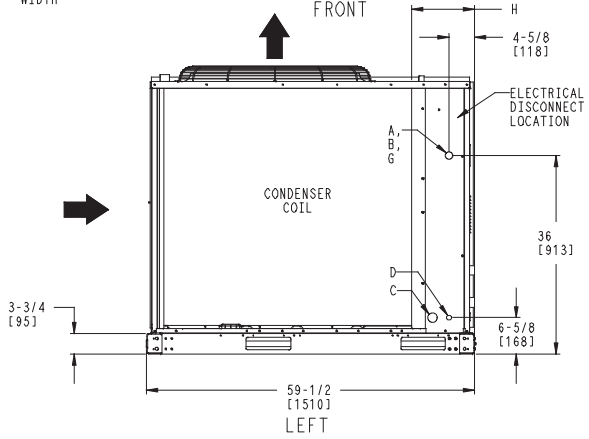
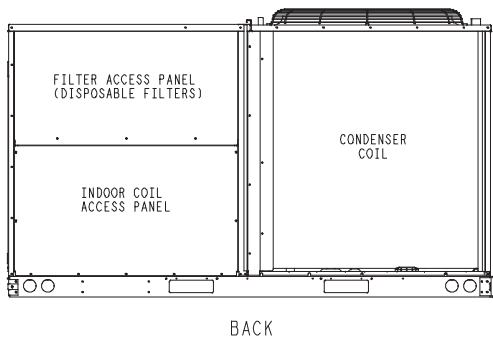
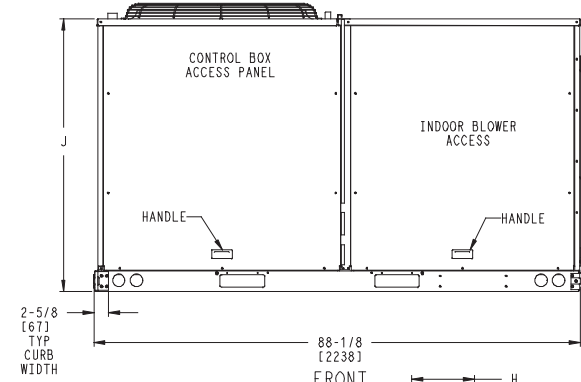
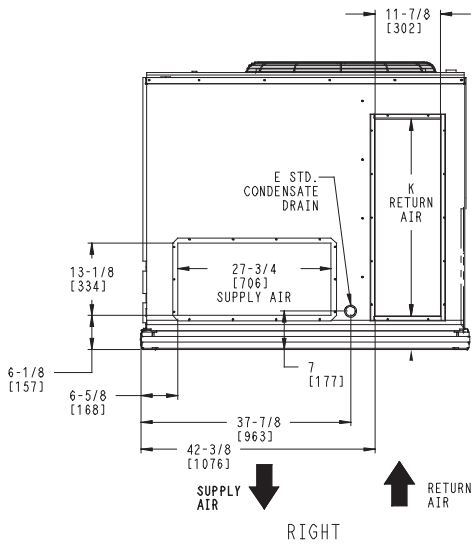
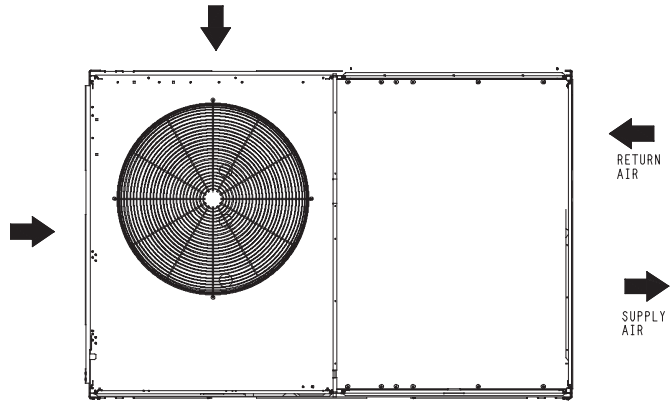

CONNECTION SIZES	
A	1 3/8" [35] DIA FIELD POWER SUPPLY HOLE
B	2 1/2" [64] DIA POWER SUPPLY KNOCKOUT
C	1 3/4" [51] DIA GAUGE ACCESS PLUG
D	7/8" [22] DIA FIELD CONTROL WIRING HOLE
E	3/4"-14 NPT CONDENSATE DRAIN
G	2" [51] DIA POWER SUPPLY KNOCK-OUT

UNIT	H	J	K
50TCMD12	11 3/8 [289]	49 3/8 [1253]	35 5/8 [905]
50TCMD14	11 3/8 [289]	49 3/8 [1253]	35 5/8 [905]

Dimensions 50TCMD12/14

CURBS & WEIGHTS DIMENSIONS - 50TCMD12/14 (cont.)

UNIT	STD. UNIT WEIGHT		CORNER WEIGHT (A)		CORNER WEIGHT (B)		CORNER WEIGHT (C)		CORNER WEIGHT (D)		CENTER OF GRAVITY (C.G.)		
	LBS.	KG.	LBS.	KG.	LBS.	KG.	LBS.	KG.	LBS.	KG.	X	Y	Z
50TCMD12	1030	467	294	133	146	66	197	89	395	179	28 3/8 (721)	33 1/8(841)	21 3/8 (543)
50TCMD14	1030	467	294	133	146	66	197	89	395	179	28 3/8 (721)	33 1/8(841)	21 3/8 (543)

NOTE: The STD, UNIT WEIGHT in the table above is for the unit equipped with NOVATION coils.
Add 65 lbs (29.5 kg) for units equipped with RTPF coils.

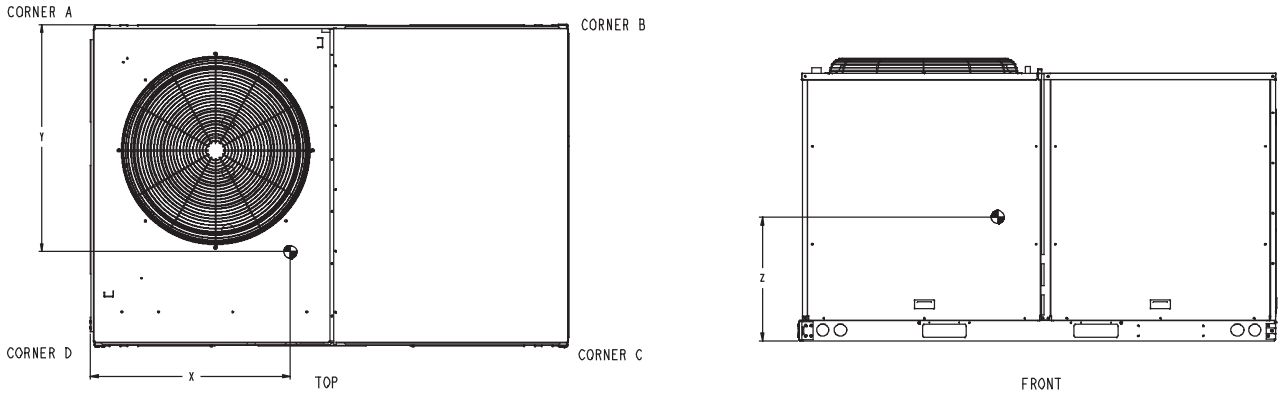

Dimensions 50TCMD12/14

C10329

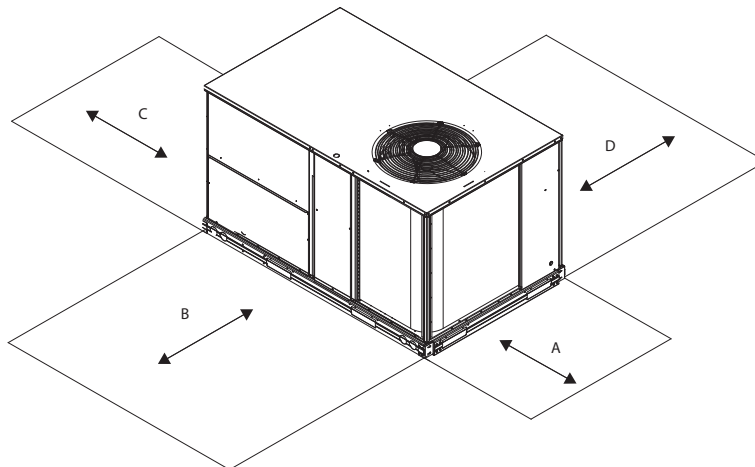

Service Clearance

C08337

LOC	DIMENSION	CONDITION
A	48-in (1219 mm)	Unit disconnect is mounted on panel
	18-in (457 mm)	No disconnect, convenience outlet option
	18-in (457 mm)	Recommended service clearance
	12-in (305 mm)	Minimum clearance
B	42-in (1067 mm)	Surface behind servicer is grounded (e.g., metal, masonry wall)
	36-in (914 mm) Special	Surface behind servicer is electrically non-conductive (e.g., wood, fiberglass) Check for sources of flue products within 10-ft of unit fresh air intake hood
C	36-in (914 mm)	Side condensate drain is used
	18-in (457 mm)	Minimum clearance
D	42-in (1067 mm)	Surface behind servicer is grounded (e.g., metal, masonry wall, another unit)
	36-in (914 mm)	Surface behind servicer is electrically non-conductive (e.g., wood, fiberglass)

Cooling Capacities

50TCM - A07 - 6 Tons - (50Hz-400V)

Temp (F) Air Entering Condenser (Edb)	Evaporator Air - CFM/BPF															
	1800 / 0.075			2100 / 0.106			2400 / 0.141			2700 / 0.178			2900 / 0.199			
	Evaporator Air - EWB (F)															
	62	67	72	62	67	72	62	67	72	62	67	72	62	67	72	
75	TC	67,602	72,823	76,377	69,485	74,302	78,096	71,229	75,295	79,527	74,296	76,072	80,878	74,435	76,646	81,673
	SHC	60,536	49,388	38,285	65,332	52,207	39,766	68,456	54,462	41,267	68,190	56,315	42,926	71,000	57,840	44,053
	kW	3.33	3.37	3.40	3.35	3.39	3.42	3.36	3.40	3.44	3.37	3.40	3.45	3.38	3.41	3.46
85	TC	63,982	69,633	74,843	66,055	71,180	76,274	68,432	72,454	77,250	70,183	73,557	78,048	71,301	74,110	78,457
	SHC	58,986	48,782	38,211	63,835	52,244	40,034	66,264	55,394	41,420	68,589	58,647	42,669	69,682	60,407	43,290
	kW	3.80	3.84	3.89	3.81	3.85	3.90	3.83	3.87	3.91	3.84	3.88	3.93	3.86	3.88	3.93
95	TC	60,834	66,971	72,826	63,558	68,514	74,368	66,024	69,764	75,573	68,154	70,736	76,499	69,287	71,252	77,004
	SHC	56,889	47,470	37,324	60,856	51,212	39,375	63,234	54,738	41,223	65,274	58,130	43,020	66,359	60,096	44,173
	kW	4.30	4.35	4.40	4.32	4.36	4.41	4.34	4.37	4.43	4.35	4.38	4.44	4.37	4.39	4.45
105	TC	59,279	65,416	72,243	62,709	67,144	73,774	65,287	68,351	74,883	67,534	69,430	75,822	68,748	70,013	76,322
	SHC	53,763	45,584	35,935	56,874	49,586	38,174	59,212	53,207	40,184	61,250	56,885	42,190	62,350	58,967	43,433
	kW	4.71	4.79	4.85	4.77	4.81	4.86	4.79	4.82	4.88	4.81	4.83	4.89	4.82	4.83	4.89
115	TC	54,531	59,427	66,651	57,883	60,995	68,056	60,348	62,219	69,077	62,501	63,354	69,982	63,687	64,035	70,487
	SHC	49,457	43,438	34,227	52,497	47,413	36,540	54,733	51,129	38,634	56,685	54,708	40,813	57,761	56,799	42,181
	kW	5.25	5.36	5.41	5.34	5.37	5.43	5.36	5.38	5.44	5.38	5.39	5.45	5.39	5.39	5.46
120	TC	52,036	56,206	63,548	55,303	57,763	64,913	57,757	58,973	65,947	59,804	60,156	66,761	60,616	60,947	67,227
	SHC	47,194	42,295	33,252	50,157	46,290	35,618	52,383	49,961	37,782	54,239	53,466	39,943	55,301	55,275	41,352
	kW	5.54	5.64	5.70	5.63	5.66	5.72	5.65	5.66	5.73	5.67	5.67	5.74	5.68	5.68	5.75
125	TC	48,643	51,870	59,194	51,715	53,407	60,528	54,037	54,629	61,437	55,696	56,024	62,214	56,802	57,112	62,632
	SHC	44,027	40,257	31,575	46,807	44,214	33,947	48,908	47,722	36,080	50,708	50,707	38,249	51,691	51,658	39,595
	kW	5.89	5.97	6.06	5.98	6.01	6.07	6.01	6.02	6.09	6.03	6.03	6.10	6.04	6.04	6.10

50TCM - A07 - 6 Tons - (50Hz-400V)

Temp (C) Air Entering Condenser (Edb)	Evaporator Air - (L/s)/BPF															
	850 / 0.075			991 / 0.106			1133 / 0.141			1274 / 0.178			1369 / 0.199			
	Evaporator Air - EWB (C)															
	17	19	22	17	19	22	17	19	22	17	19	22	17	19	22	
24	TC	19.8	21.3	22.4	20.4	21.8	22.9	20.9	22.1	23.3	21.8	22.3	23.7	21.8	22.5	23.9
	SHC	17.7	14.5	11.2	19.1	15.3	11.7	20.1	16.0	12.1	20.0	16.5	12.6	20.8	17.0	12.9
	kW	3.33	3.37	3.40	3.35	3.39	3.42	3.36	3.40	3.44	3.37	3.40	3.45	3.38	3.41	3.46
29	TC	18.8	20.4	21.9	19.4	20.9	22.4	20.1	21.2	22.6	20.6	21.6	22.9	20.9	21.7	23.0
	SHC	17.3	14.3	11.2	18.7	15.3	11.7	19.4	16.2	12.1	20.1	17.2	12.5	20.4	17.7	12.7
	kW	3.80	3.84	3.89	3.81	3.85	3.90	3.83	3.87	3.91	3.84	3.88	3.93	3.86	3.88	3.93
35	TC	17.8	19.6	21.3	18.6	20.1	21.8	19.4	20.4	22.1	20.0	20.7	22.4	20.3	20.9	22.6
	SHC	16.7	13.9	10.9	17.8	15.0	11.5	18.5	16.0	12.1	19.1	17.0	12.6	19.4	17.6	12.9
	kW	4.30	4.35	4.40	4.32	4.36	4.41	4.34	4.37	4.43	4.35	4.38	4.44	4.37	4.39	4.45
40.6	TC	17.4	19.2	21.2	18.4	19.7	21.6	19.1	20.0	21.9	19.8	20.3	22.2	20.1	20.5	22.4
	SHC	15.8	13.4	10.5	16.7	14.5	11.2	17.4	15.6	11.8	18.0	16.7	12.4	18.3	17.3	12.7
	kW	4.71	4.79	4.85	4.77	4.81	4.86	4.79	4.82	4.88	4.81	4.83	4.89	4.82	4.83	4.89
46	TC	16.0	17.4	19.5	17.0	17.9	19.9	17.7	18.2	20.2	18.3	18.6	20.5	18.7	18.8	20.7
	SHC	14.5	12.7	10.0	15.4	13.9	10.7	16.0	15.0	11.3	16.6	16.0	12.0	16.9	16.6	12.4
	kW	5.25	5.36	5.41	5.34	5.37	5.43	5.36	5.38	5.44	5.38	5.39	5.45	5.39	5.39	5.46
49	TC	15.3	16.5	18.6	16.2	16.9	19.0	16.9	17.3	19.3	17.5	17.6	19.6	17.8	17.9	19.7
	SHC	13.8	12.4	9.7	14.7	13.6	10.4	15.4	14.6	11.1	15.9	15.7	11.7	16.2	16.2	12.1
	kW	5.54	5.64	5.70	5.63	5.66	5.72	5.65	5.66	5.73	5.67	5.67	5.74	5.68	5.68	5.75
52	TC	14.3	15.2	17.3	15.2	15.7	17.7	15.8	16.0	18.0	16.3	16.4	18.2	16.6	16.7	18.4
	SHC	12.9	11.8	9.3	13.7	13.0	9.9	14.3	14.0	10.6	14.9	14.9	11.2	15.1	15.1	11.6
	kW	5.89	5.97	6.06	5.98	6.01	6.07	6.01	6.02	6.09	6.03	6.03	6.10	6.04	6.04	6.10

LEGEND

BPF — Bypass Factor
 Edb — Entering Dry-Bulb
 Ewb — Entering Wet-Bulb
 SHC — Sensible Heat Capacity (1000 Btuh) Gross
Bold, Italics - Standard Ratings

Ldb — Leaving Dry-Bulb
 Lwb — Leaving Wet-Bulb
 TC — Total Capacity (1000 Btuh) Gross
 kW — Compressor Motor Power Input

Notes:

- Direct interpolation is permissible. Do not extrapolate.
- The following formulas may be used.

$$t_{ldb} = t_{edb} - \frac{\text{sensible capacity (Btuh)}}{1.10 \times \text{cfm}}$$

t_{lwb} = Wet-bulb temperature corresponding to enthalpy of air leaving evaporator coil (h_{lwb}).

$$h_{lwb} = h_{ewb} - \frac{\text{total capacity (Btuh)}}{4.5 \times \text{cfm}}$$

Where: h_{ewb} = Enthalpy of air entering evaporator coil.

- Cooling capacities are gross and do not include deductions for indoor fan motor heat.
- Variable Air Volume units will operate down to 70 cfm/ton. Performance at 70 cfm/ton is limited to unloaded operation and may be additionally limited to edb and ewb conditions.

- The SHC is based on 80 F edb temperature of air entering evaporator coil.
 - Below 80 F edb, subtract (corr factor x cfm) from SHC.
 - Above 80 F edb, add (corr factor x cfm) to SHC.

BF	ENTERING AIR DRY-BULB TEMP (F)					
	79	78	77	76	75	under 75
	81	82	83	84	85	over 85
Correction Factor						
0.05	1.04	2.07	3.11	4.14	5.18	Use formula shown below.*
0.10	0.98	1.96	2.94	3.92	4.90	
0.20	0.87	1.74	2.62	3.49	4.36	
0.30	0.76	1.53	2.29	3.05	3.82	

- Interpolation is permissible.

*Correction Factor = 1.10 x (1 - BF) x (edb - 80).

Cooling Capacities (Continued)

50TCM - D08 - 7.5 Tons - (50Hz-400V)

Temp (F) Air Entering Condenser (Edb)	Evaporator Air - CFM/BPF															
	2250 / 0.098			2625 / 0.126			3000 / 0.152			3375 / 0.185			3750 / 0.206			
	Evaporator Air - EWB (F)															
	62	67	72	62	67	72	62	67	72	62	67	72	62	67	72	
75	TC	83,305	91,307	96,838	85,808	93,420	98,292	87,908	94,597	99,305	90,558	95,700	100,387	92,004	96,295	101,036
	SHC	73,659	61,796	48,759	79,482	66,013	50,742	83,975	69,244	52,366	88,621	72,973	54,345	85,332	75,242	55,617
	kW	3.71	3.68	3.70	3.68	3.71	3.69	3.69	3.71	3.68	3.69	3.72	3.69	3.69	3.69	3.73
85	TC	79,486	87,533	95,240	82,029	89,889	96,773	84,308	91,420	97,763	87,415	92,900	98,864	89,479	93,652	99,428
	SHC	70,413	59,070	47,429	76,091	63,607	49,730	79,985	67,248	51,485	83,575	71,713	53,673	84,518	74,524	55,008
	kW	4.32	4.32	4.32	4.33	4.31	4.33	4.32	4.31	4.33	4.31	4.31	4.34	4.31	4.32	4.35
95	TC	77,570	85,631	94,421	80,458	87,981	96,523	83,095	89,571	97,828	86,195	91,177	99,012	88,016	92,035	99,595
	SHC	73,850	61,844	49,795	79,533	66,794	52,707	82,889	70,875	55,022	86,197	76,091	57,785	88,018	79,195	59,448
	kW	4.98	5.04	5.04	5.01	5.04	5.05	5.04	5.03	5.06	5.04	5.03	5.06	5.03	5.04	5.07
105	TC	69,946	77,442	85,990	73,222	79,499	88,097	75,870	80,904	89,431	78,770	82,397	90,753	80,417	83,225	91,425
	SHC	66,424	55,707	44,639	70,836	60,312	47,503	73,406	64,205	49,821	76,212	69,003	52,672	77,805	71,838	54,436
	kW	5.41	5.52	5.55	5.46	5.54	5.56	5.50	5.54	5.57	5.54	5.55	5.57	5.54	5.55	5.58
115	TC	62,712	69,242	77,591	66,199	71,108	79,552	68,782	72,384	80,848	71,481	73,812	82,156	72,988	74,572	82,806
	SHC	61,696	52,564	41,898	65,127	57,206	44,750	67,668	60,980	47,095	70,324	65,564	50,046	71,806	68,362	51,891
	kW	6.23	6.35	6.49	6.30	6.40	6.50	6.35	6.43	6.50	6.41	6.46	6.51	6.45	6.48	6.51
120	TC	59,541	66,318	74,676	63,753	68,065	76,545	66,237	69,423	77,808	68,938	70,762	79,102	70,412	71,542	79,780
	SHC	58,258	50,825	40,463	61,572	55,366	43,272	63,992	59,094	45,589	66,595	63,584	48,495	68,049	66,272	50,350
	kW	6.76	6.76	6.94	6.84	6.81	6.95	6.90	6.84	6.96	6.96	6.88	6.97	7.00	6.90	6.97
125	TC	55,970	60,802	69,255	59,233	62,545	71,009	61,579	63,808	72,184	64,179	65,152	73,396	65,632	66,063	74,019
	SHC	55,972	49,286	39,138	59,235	53,779	41,983	61,580	57,475	44,319	64,180	61,919	47,272	65,633	64,470	49,110
	kW	7.14	7.26	7.49	7.22	7.31	7.53	7.29	7.35	7.55	7.36	7.39	7.56	7.40	7.41	7.56

50TCM - D08 - 7.5 Tons - (50Hz-400V)

Temp (C) Air Entering Condenser (Edb)	Evaporator Air - (L/s)/BPF															
	1062 / 0.098			1239 / 0.126			1416 / 0.152			1593 / 0.185			1770 / 0.206			
	Evaporator Air - EWB (C)															
	17	19	22	17	19	22	17	19	22	17	19	22	17	19	22	
24	TC	24.4	26.8	28.4	25.1	27.4	28.8	25.8	27.7	29.1	26.5	28.0	29.4	27.0	28.2	29.6
	SHC	21.6	18.1	14.3	23.3	19.3	14.9	24.6	20.3	15.3	26.0	21.4	15.9	25.0	22.1	16.3
	kW	3.71	3.68	3.70	3.70	3.68	3.71	3.69	3.69	3.71	3.68	3.69	3.72	3.69	3.69	3.73
29	TC	23.3	25.7	27.9	24.0	26.3	28.4	24.7	26.8	28.7	25.6	27.2	29.0	26.2	27.4	29.1
	SHC	20.6	17.3	13.9	22.3	18.6	14.6	23.4	19.7	15.1	24.5	21.0	15.7	24.8	21.8	16.1
	kW	4.32	4.32	4.32	4.33	4.31	4.33	4.32	4.31	4.33	4.31	4.31	4.34	4.31	4.32	4.35
35	TC	22.7	25.1	27.7	23.6	25.8	28.3	24.4	26.3	28.7	25.3	26.7	29.0	25.8	27.0	29.2
	SHC	21.6	18.1	14.6	23.3	19.6	15.4	24.3	20.8	16.1	25.3	22.3	16.9	25.8	23.2	17.4
	kW	4.98	5.04	5.04	5.01	5.04	5.05	5.04	5.03	5.06	5.04	5.03	5.06	5.03	5.04	5.07
40.6	TC	20.5	22.7	25.2	21.5	23.3	25.8	22.2	23.7	26.2	23.1	24.1	26.6	23.6	24.4	26.8
	SHC	19.5	16.3	13.1	20.8	17.7	13.9	21.5	18.8	14.6	22.3	20.2	15.4	22.8	21.1	16.0
	kW	5.41	5.52	5.55	5.46	5.54	5.56	5.50	5.54	5.57	5.54	5.55	5.57	5.54	5.55	5.58
46	TC	18.4	20.3	22.7	19.4	20.8	23.3	20.2	21.2	23.7	20.9	21.6	24.1	21.4	21.9	24.3
	SHC	18.1	15.4	12.3	19.1	16.8	13.1	19.8	17.9	13.8	20.6	19.2	14.7	21.0	20.0	15.2
	kW	6.23	6.35	6.49	6.30	6.40	6.50	6.35	6.43	6.50	6.41	6.46	6.51	6.45	6.48	6.51
49	TC	17.5	19.4	21.9	18.7	19.9	22.4	19.4	20.3	22.8	20.2	20.7	23.2	20.6	21.0	23.4
	SHC	17.1	14.9	11.9	18.0	16.2	12.7	18.8	17.3	13.4	19.5	18.6	14.2	19.9	19.4	14.8
	kW	6.76	6.76	6.94	6.84	6.81	6.95	6.90	6.84	6.96	6.96	6.88	6.97	7.00	6.90	6.97
52	TC	16.4	17.8	20.3	17.4	18.3	20.8	18.0	18.7	21.2	18.8	19.1	21.5	19.2	19.4	21.7
	SHC	16.4	14.4	11.5	17.4	15.8	12.3	18.0	16.8	13.0	18.8	18.1	13.9	19.2	18.9	14.4
	kW	7.14	7.26	7.49	7.22	7.31	7.53	7.29	7.35	7.55	7.36	7.39	7.56	7.40	7.41	7.56

LEGEND

BPF — Bypass Factor
 Edb — Entering Dry-Bulb
 Ewb — Entering Wet-Bulb
 SHC — Sensible Heat Capacity (1000 Btuh) Gross
Bold, Italics - Standard Ratings

Ldb — Leaving Dry-Bulb
 Lwb — Leaving Wet-Bulb
 TC — Total Capacity (1000 Btuh) Gross
 kW — Compressor Motor Power Input

Notes:

- Direct interpolation is permissible. Do not extrapolate.
- The following formulas may be used.

$$t_{ldb} = t_{edb} - \frac{\text{sensible capacity (Btuh)}}{1.10 \times \text{cfm}}$$

t_{lwb} = Wet-bulb temperature corresponding to enthalpy of air leaving evaporator coil (h_{lwb}).

$$h_{lwb} = h_{ewb} - \frac{\text{total capacity (Btuh)}}{4.5 \times \text{cfm}}$$

Where: h_{ewb} = Enthalpy of air entering evaporator coil.

- Cooling capacities are gross and do not include deductions for indoor fan motor heat.
- Variable Air Volume units will operate down to 70 cfm/ton. Performance at 70 cfm/ton is limited to unloaded operation and may be additionally limited to edb and ewb conditions.

- The SHC is based on 80 F edb temperature of air entering evaporator coil.
 - Below 80 F edb, subtract (corr factor x cfm) from SHC.
 - Above 80 F edb, add (corr factor x cfm) to SHC.

BF	ENTERING AIR DRY-BULB TEMP (F)					
	79	78	77	76	75	under 75
	81	82	83	84	85	over 85
Correction Factor						
0.05	1.04	2.07	3.11	4.14	5.18	Use formula shown below.*
0.10	0.98	1.96	2.94	3.92	4.90	
0.20	0.87	1.74	2.62	3.49	4.36	
0.30	0.76	1.53	2.29	3.05	3.82	

- Interpolation is permissible.

*Correction Factor = 1.10 x (1 - BF) x (edb - 80).

Cooling Capacities (Continued)

50TCM - D09 - 8.5 Tons - (50Hz-400V)

Temp (F) Air Entering Condenser (Edb)		Evaporator Air - CFM/BPF														
		2550 / 0.077			2975 / 0.111			3400 / 0.140			3650 / 0.169			4250 / 0.193		
		Evaporator Air - EWB (F)														
		62	67	72	62	67	72	62	67	72	62	67	72	62	67	72
75	TC	94,796	105,114	116,069	99,041	108,553	119,409	102,511	110,893	122,038	105,680	112,805	124,081	107,466	114,214	125,772
	SHC	83,773	71,727	58,510	90,437	77,678	62,226	96,556	83,362	65,831	101,811	88,659	69,208	102,214	93,617	72,563
	kW	4.35	4.46	4.59	4.40	4.51	4.63	4.43	4.54	4.67	4.48	4.56	4.70	4.60	4.58	4.72
85	TC	89,812	99,380	110,428	94,039	102,395	113,937	97,370	104,698	116,379	100,522	106,485	118,254	103,532	108,182	119,818
	SHC	80,717	69,420	56,447	86,824	75,348	60,289	92,771	80,962	63,876	97,561	86,169	67,251	100,482	91,357	70,591
	kW	4.94	5.06	5.19	5.00	5.10	5.25	5.04	5.13	5.28	5.08	5.15	5.31	5.11	5.18	5.34
95	TC	83,989	93,368	103,939	87,930	95,978	106,944	91,757	98,105	109,317	95,271	99,717	111,121	98,135	101,312	112,645
	SHC	76,848	67,001	54,103	83,156	72,815	57,836	89,054	78,370	61,456	92,464	83,453	64,855	95,244	88,039	68,224
	kW	5.59	5.73	5.86	5.63	5.76	5.90	5.69	5.79	5.93	5.75	5.81	5.96	5.79	5.83	5.98
105	TC	77,883	85,789	97,104	81,803	88,496	99,821	85,789	90,613	101,876	89,065	92,683	103,498	92,012	94,753	104,830
	SHC	72,703	64,039	51,663	79,393	69,863	55,362	83,261	75,372	58,939	86,441	79,987	62,314	89,301	83,869	65,659
	kW	6.41	6.52	6.71	6.47	6.56	6.75	6.52	6.59	6.79	6.57	6.64	6.81	6.62	6.68	6.84
115	TC	71,531	78,044	89,148	75,800	80,364	91,870	79,464	82,585	94,119	82,512	84,811	95,543	85,202	86,697	96,688
	SHC	68,065	60,055	48,121	72,463	65,613	51,842	75,966	70,291	55,484	78,880	74,086	58,783	81,451	77,758	62,057
	kW	7.26	7.35	7.52	7.32	7.39	7.58	7.37	7.42	7.64	7.42	7.45	7.67	7.46	7.48	7.70
120	TC	71,681	77,508	88,891	75,890	79,759	91,546	79,548	82,435	93,661	82,617	84,604	95,386	85,322	86,410	96,595
	SHC	66,529	58,959	47,144	70,437	64,225	50,837	73,831	68,669	54,434	76,680	72,400	57,834	79,190	76,128	61,131
	kW	7.70	7.77	7.94	7.75	7.80	7.99	7.80	7.84	8.04	7.85	7.87	8.10	7.89	7.90	8.13
125	TC	67,705	72,037	83,312	71,723	74,575	85,788	75,153	77,233	87,627	78,076	79,321	89,001	80,612	81,158	90,153
	SHC	62,717	56,828	45,240	66,440	61,255	48,919	69,617	65,478	52,463	72,324	69,193	55,764	74,674	72,962	59,051
	kW	8.31	8.37	8.53	8.36	8.40	8.58	8.41	8.44	8.62	8.46	8.47	8.65	8.50	8.50	8.68

50TCM - D09 - 8.5 Tons - (50Hz-400V)

Temp (C) Air Entering Condenser (Edb)		Evaporator Air - (L/s)/BPF														
		1203 / 0.077			1404 / 0.111			1605 / 0.140			1723 / 0.169			2006 / 0.193		
		Evaporator Air - EWB (C)														
		17	19	22	17	19	22	17	19	22	17	19	22	17	19	22
24	TC	27.8	30.8	34.0	29.0	31.8	35.0	30.0	32.5	35.8	31.0	33.1	36.4	31.5	33.5	36.9
	SHC	24.6	21.0	17.1	26.5	22.8	18.2	28.3	24.4	19.3	29.8	26.0	20.3	30.0	27.4	21.3
	kW	4.35	4.46	4.59	4.40	4.51	4.63	4.43	4.54	4.67	4.48	4.56	4.70	4.60	4.58	4.72
29	TC	26.3	29.1	32.4	27.6	30.0	33.4	28.5	30.7	34.1	29.5	31.2	34.7	30.3	31.7	35.1
	SHC	23.7	20.3	16.5	25.4	22.1	17.7	27.2	23.7	18.7	28.6	25.3	19.7	29.4	26.8	20.7
	kW	4.94	5.06	5.19	5.00	5.10	5.25	5.04	5.13	5.28	5.08	5.15	5.31	5.11	5.18	5.34
35	TC	24.6	27.4	30.5	25.8	28.1	31.3	26.9	28.8	32.0	27.9	29.2	32.6	28.8	29.7	33.0
	SHC	22.5	19.6	15.9	24.4	21.3	17.0	26.1	23.0	18.0	27.1	24.5	19.0	27.9	25.8	20.0
	kW	5.59	5.73	5.86	5.63	5.76	5.90	5.69	5.79	5.93	5.75	5.81	5.96	5.79	5.83	5.98
40.6	TC	22.8	25.1	28.5	24.0	25.9	29.3	25.1	26.6	29.9	26.1	27.2	30.3	27.0	27.8	30.7
	SHC	21.3	18.8	15.1	23.3	20.5	16.2	24.4	22.1	17.3	25.3	23.4	18.3	26.2	24.6	19.2
	kW	6.41	6.52	6.71	6.47	6.56	6.75	6.52	6.59	6.79	6.57	6.64	6.81	6.62	6.68	6.84
46	TC	21.0	22.9	26.1	22.2	23.6	26.9	23.3	24.2	27.6	24.2	24.9	28.0	25.0	25.4	28.3
	SHC	19.9	17.6	14.1	21.2	19.2	15.2	22.3	20.6	16.3	23.1	21.7	17.2	23.9	22.8	18.2
	kW	7.26	7.35	7.52	7.32	7.39	7.58	7.37	7.42	7.64	7.42	7.45	7.67	7.46	7.48	7.70
49	TC	21.0	22.7	26.1	22.2	23.4	26.8	23.3	24.2	27.5	24.2	24.8	28.0	25.0	25.3	28.3
	SHC	19.5	17.3	13.8	20.6	18.8	14.9	21.6	20.1	16.0	22.5	21.2	17.0	23.2	22.3	17.9
	kW	7.70	7.77	7.94	7.75	7.80	7.99	7.80	7.84	8.04	7.85	7.87	8.10	7.89	7.90	8.13
52	TC	19.8	21.1	24.4	21.0	21.9	25.1	22.0	22.6	25.7	22.9	23.2	26.1	23.6	23.8	26.4
	SHC	18.4	16.7	13.3	19.5	18.0	14.3	20.4	19.2	15.4	21.2	20.3	16.3	21.9	21.4	17.3
	kW	8.31	8.37	8.53	8.36	8.40	8.58	8.41	8.44	8.62	8.46	8.47	8.65	8.50	8.50	8.68

LEGEND

BPF — Bypass Factor
 Edb — Entering Dry-Bulb
 Ewb — Entering Wet-Bulb
 SHC — Sensible Heat Capacity (1000 Btuh) Gross
Bold, Italics - Standard Ratings

Ldb — Leaving Dry-Bulb
 Lwb — Leaving Wet-Bulb
 TC — Total Capacity (1000 Btuh) Gross
 kW — Compressor Motor Power Input

Notes:

- Direct interpolation is permissible. Do not extrapolate.
- The following formulas may be used.

$$t_{ldb} = t_{edb} - \frac{\text{sensible capacity (Btuh)}}{1.10 \times \text{cfm}}$$

t_{lwb} = Wet-bulb temperature corresponding to enthalpy of air leaving evaporator coil (h_{lwb}).

$$h_{lwb} = h_{ewb} - \frac{\text{total capacity (Btuh)}}{4.5 \times \text{cfm}}$$

Where: h_{ewb} = Enthalpy of air entering evaporator coil.

- Cooling capacities are gross and do not include deductions for indoor fan motor heat.
- Variable Air Volume units will operate down to 70 cfm/ton. Performance at 70 cfm/ton is limited to unloaded operation and may be additionally limited to edb and ewb conditions.

- The SHC is based on 80 F edb temperature of air entering evaporator coil.
 - Below 80 F edb, subtract (corr factor x cfm) from SHC.
 - Above 80 F edb, add (corr factor x cfm) to SHC.

BF	ENTERING AIR DRY-BULB TEMP (F)					
	79	78	77	76	75	under 75
	81	82	83	84	85	over 85
	Correction Factor					
0.05	1.04	2.07	3.11	4.14	5.18	Use formula shown below.*
0.10	0.98	1.96	2.94	3.92	4.90	
0.20	0.87	1.74	2.62	3.49	4.36	
0.30	0.76	1.53	2.29	3.05	3.82	

- Interpolation is permissible.

*Correction Factor = 1.10 x (1 - BF) x (edb - 80).

Cooling Capacities (Continued)

50TCM - D12 - 10 Tons - (50Hz-400V)

Temp (F) Air Entering Condenser (Edb)		Evaporator Air - CFM/BPF														
		3000 / 0.061			3500 / 0.087			4000 / 0.117			4500 / 0.146			5000 / 0.177		
		Evaporator Air - EWB (F)														
		62	67	72	62	67	72	62	67	72	62	67	72	62	67	72
75	TC	117,319	126,635	133,517	120,555	129,085	136,226	120,555	129,085	136,226	125,885	131,612	139,974	126,352	132,497	141,221
	SHC	103,482	85,468	66,691	111,492	90,987	69,774	114,255	94,771	71,749	119,540	98,419	74,772	115,796	101,099	76,576
	kW	5.08	5.14	5.23	5.09	5.17	5.27	5.11	5.20	5.31	5.12	5.21	5.32	5.17	5.22	5.35
85	TC	112,254	122,512	131,590	116,040	125,632	133,824	116,040	125,632	133,824	121,585	128,623	136,410	123,432	129,435	137,463
	SHC	101,678	84,789	66,705	109,358	91,653	70,033	111,738	96,316	72,218	117,082	100,916	74,716	118,885	103,796	76,522
	kW	5.91	5.95	6.06	5.92	5.98	6.09	5.94	6.00	6.12	5.95	6.01	6.13	5.97	6.03	6.15
95	TC	106,032	116,259	127,536	110,419	119,203	130,277	110,419	119,203	130,277	116,401	122,315	132,790	118,183	123,193	133,528
	SHC	97,862	82,598	65,954	105,689	89,581	69,982	106,351	94,488	72,633	112,112	99,392	75,332	113,829	102,510	77,073
	kW	6.77	6.87	6.94	6.84	6.89	6.98	6.86	6.90	7.02	6.86	6.91	7.02	6.88	6.92	7.04
105	TC	98,856	108,839	120,381	103,936	111,676	123,218	103,936	111,676	123,218	110,358	114,654	126,223	112,060	115,495	127,000
	SHC	93,327	79,812	63,506	100,106	86,893	67,837	100,106	91,871	70,742	106,292	96,789	73,972	107,931	100,033	75,952
	kW	7.51	7.68	7.77	7.61	7.71	7.80	7.68	7.73	7.82	7.70	7.73	7.83	7.72	7.74	7.84
115	TC	87,466	95,619	107,577	92,684	98,404	110,141	92,684	98,404	110,141	98,786	101,367	112,842	100,377	102,200	113,553
	SHC	87,315	75,946	60,357	92,524	83,069	64,727	92,524	88,006	67,775	98,616	92,950	71,001	100,203	95,606	73,044
	kW	7.80	7.98	8.17	7.92	8.04	8.19	8.01	8.07	8.21	8.03	8.08	8.21	8.06	8.09	8.22
120	TC	82,271	89,456	101,242	87,254	92,101	103,754	87,254	92,101	103,754	93,146	95,084	106,320	94,687	96,050	106,985
	SHC	78,984	69,532	55,216	83,768	76,195	59,339	83,768	80,665	62,197	89,425	85,103	65,197	90,904	87,269	67,137
	kW	8.56	8.73	8.97	8.68	8.81	9.01	8.79	8.85	9.03	8.82	8.85	9.03	8.85	8.87	9.05
125	TC	76,521	81,918	93,952	81,234	84,436	96,318	81,234	84,436	96,318	86,992	88,112	99,000	88,439	89,123	99,563
	SHC	73,461	66,293	52,522	77,986	72,848	56,630	77,986	75,892	59,475	83,513	80,621	62,592	84,902	82,871	64,460
	kW	9.17	9.32	9.61	9.30	9.40	9.66	9.42	9.46	9.70	9.47	9.48	9.72	9.50	9.51	9.73

50TCM - D12 - 10 Tons - (50Hz-400V)

Temp (C) Air Entering Condenser (Edb)		Evaporator Air - (L/s)/BPF														
		1416 / 0.061			1652 / 0.087			1888 / 0.117			2124 / 0.146			2360 / 0.177		
		Evaporator Air - EWB (C)														
		17	19	22	17	19	22	17	19	22	17	19	22	17	19	22
24	TC	34.4	37.1	39.1	35.3	37.8	39.9	35.3	37.8	39.9	36.9	38.6	41.0	37.0	38.8	41.4
	SHC	30.3	25.0	19.5	32.7	26.7	20.4	33.5	27.8	21.0	35.0	28.8	21.9	33.9	29.6	22.4
	kW	5.08	5.14	5.23	5.09	5.17	5.27	5.11	5.20	5.31	5.12	5.21	5.32	5.17	5.22	5.35
29	TC	32.9	35.9	38.6	34.0	36.8	39.2	34.0	36.8	39.2	35.6	37.7	40.0	36.2	37.9	40.3
	SHC	29.8	24.9	19.6	32.1	26.9	20.5	32.7	28.2	21.2	34.3	29.6	21.9	34.8	30.4	22.4
	kW	5.91	5.95	6.06	5.92	5.98	6.09	5.94	6.00	6.12	5.95	6.01	6.13	5.97	6.03	6.15
35	TC	31.1	34.1	37.4	32.4	34.9	38.2	32.4	34.9	38.2	34.1	35.8	38.9	34.6	36.1	39.1
	SHC	28.7	24.2	19.3	31.0	26.3	20.5	31.2	27.7	21.3	32.9	29.1	22.1	33.4	30.0	22.6
	kW	6.77	6.87	6.94	6.84	6.89	6.98	6.86	6.90	7.02	6.86	6.91	7.02	6.88	6.92	7.04
40.6	TC	29.0	31.9	35.3	30.5	32.7	36.1	30.5	32.7	36.1	32.3	33.6	37.0	32.8	33.8	37.2
	SHC	27.4	23.4	18.6	29.3	25.5	19.9	29.3	26.9	20.7	31.2	28.4	21.7	31.6	29.3	22.3
	kW	7.51	7.68	7.77	7.61	7.71	7.80	7.68	7.73	7.82	7.70	7.73	7.83	7.72	7.74	7.84
46	TC	25.6	28.0	31.5	27.2	28.8	32.3	27.2	28.8	32.3	29.0	29.7	33.1	29.4	30.0	33.3
	SHC	25.6	22.3	17.7	27.1	24.3	19.0	27.1	25.8	19.9	28.9	27.2	20.8	29.4	28.0	21.4
	kW	7.80	7.98	8.17	7.92	8.04	8.19	8.01	8.07	8.21	8.03	8.08	8.21	8.06	8.09	8.22
49	TC	24.1	26.2	29.7	25.6	27.0	30.4	25.6	27.0	30.4	27.3	27.9	31.2	27.8	28.2	31.4
	SHC	23.1	20.4	16.2	24.6	22.3	17.4	24.6	23.6	18.2	26.2	24.9	19.1	26.6	25.6	19.7
	kW	8.56	8.73	8.97	8.68	8.81	9.01	8.79	8.85	9.03	8.82	8.85	9.03	8.85	8.87	9.05
52	TC	22.4	24.0	27.5	23.8	24.7	28.2	23.8	24.7	28.2	25.5	25.8	29.0	25.9	26.1	29.2
	SHC	21.5	19.4	15.4	22.9	21.4	16.6	22.9	22.2	17.4	24.5	23.6	18.3	24.9	24.3	18.9
	kW	9.17	9.32	9.61	9.30	9.40	9.66	9.42	9.46	9.70	9.47	9.48	9.72	9.50	9.51	9.73

LEGEND

BPF — Bypass Factor
 Edb — Entering Dry-Bulb
 Ewb — Entering Wet-Bulb
 SHC — Sensible Heat Capacity (1000 Btuh) Gross
Bold, Italics - Standard Ratings

Ldb — Leaving Dry-Bulb
 Lwb — Leaving Wet-Bulb
 TC — Total Capacity (1000 Btuh) Gross
 kW — Compressor Motor Power Input

Notes:

- Direct interpolation is permissible. Do not extrapolate.
- The following formulas may be used.

$$t_{ldb} = t_{edb} - \frac{\text{sensible capacity (Btuh)}}{1.10 \times \text{cfm}}$$

t_{lwb} = Wet-bulb temperature corresponding to enthalpy of air leaving evaporator coil (h_{lwb}).

$$h_{lwb} = h_{ewb} - \frac{\text{total capacity (Btuh)}}{4.5 \times \text{cfm}}$$

Where: h_{ewb} = Enthalpy of air entering evaporator coil.

- Cooling capacities are gross and do not include deductions for indoor fan motor heat.
- Variable Air Volume units will operate down to 70 cfm/ton. Performance at 70 cfm/ton is limited to unloaded operation and may be additionally limited to edb and ewb conditions.

- The SHC is based on 80 F edb temperature of air entering evaporator coil.
 - Below 80 F edb, subtract (corr factor x cfm) from SHC.
 - Above 80 F edb, add (corr factor x cfm) to SHC.

BF	ENTERING AIR DRY-BULB TEMP (F)					
	79	78	77	76	75	under 75
	81	82	83	84	85	over 85
	Correction Factor					
0.05	1.04	2.07	3.11	4.14	5.18	Use formula shown below.*
0.10	0.98	1.96	2.94	3.92	4.90	
0.20	0.87	1.74	2.62	3.49	4.36	
0.30	0.76	1.53	2.29	3.05	3.82	

- Interpolation is permissible.

*Correction Factor = 1.10 x (1 - BF) x (edb - 80).

Cooling Capacities (Continued)

50TCM - D14 - 12.5 Tons - (50Hz-400V)

Temp (F) Air Entering Condenser (Edb)	Evaporator Air - CFM/BPF															
	3600 / 0.041			4200 / 0.058			4800 / 0.088			5400 / 0.111			5900 / 0.131			
	Evaporator Air - EWB (F)															
	62	67	72	62	67	72	62	67	72	62	67	72	62	67	72	
75	TC	137,377	147,352	161,040	141,096	150,955	161,759	144,161	153,854	163,532	147,138	155,516	164,987	150,115	156,170	165,515
	SHC	125,475	103,167	78,288	135,267	111,416	86,857	140,395	119,371	90,691	144,619	126,486	94,321	148,844	129,714	96,027
	kW	6.54	6.57	6.59	6.52	6.56	6.60	6.54	6.56	6.62	6.54	6.57	6.63	6.54	6.57	6.64
85	TC	132,570	143,462	154,554	136,517	146,897	158,168	140,582	149,254	160,237	144,647	151,000	161,730	146,324	151,850	162,319
	SHC	123,464	102,284	81,003	132,641	110,563	86,091	138,032	118,207	90,480	143,423	125,535	94,581	145,086	129,028	96,530
	kW	7.57	7.56	7.58	7.53	7.55	7.58	7.53	7.55	7.60	7.53	7.55	7.61	7.54	7.55	7.62
95	TC	125,256	137,940	149,720	130,956	140,868	152,617	135,826	143,178	154,703	139,702	144,904	156,342	141,378	145,679	156,980
	SHC	119,777	100,358	79,588	129,106	108,428	84,346	134,676	116,223	88,909	138,519	123,726	93,282	140,181	127,233	95,427
	kW	8.54	8.66	8.64	8.62	8.65	8.65	8.65	8.65	8.67	8.64	8.65	8.68	8.63	8.64	8.69
105	TC	116,767	130,199	143,082	123,543	133,503	145,924	129,251	135,962	147,948	133,618	137,661	149,493	135,295	138,443	150,092
	SHC	114,304	97,274	77,232	122,497	105,685	82,184	128,157	113,699	86,878	132,487	121,244	91,390	134,149	124,925	93,552
	kW	9.36	9.61	9.63	9.49	9.65	9.63	9.60	9.65	9.64	9.64	9.65	9.65	9.64	9.64	9.65
115	TC	102,026	112,282	127,304	108,287	115,750	130,150	113,501	118,406	132,105	117,948	120,848	133,584	119,818	121,815	134,178
	SHC	104,909	90,867	72,791	111,347	99,359	77,866	116,708	107,426	82,660	121,281	115,271	87,256	123,203	118,915	89,502
	kW	9.69	9.85	10.09	9.79	9.92	10.09	9.88	9.97	10.09	9.97	10.03	10.09	10.01	10.05	10.09
120	TC	99,266	108,630	123,952	105,263	112,036	126,995	110,419	114,455	129,051	114,679	116,841	130,515	116,658	117,904	131,147
	SHC	95,822	83,878	67,191	101,611	91,848	72,077	106,587	99,438	76,657	110,700	106,599	81,089	112,610	110,105	83,237
	kW	10.56	10.72	11.00	10.66	10.79	11.04	10.76	10.84	11.04	10.85	10.89	11.04	10.89	10.92	11.04
125	TC	93,279	100,645	116,145	99,033	103,801	119,288	103,896	106,369	121,455	108,061	108,752	123,140	109,914	110,371	123,827
	SHC	90,522	80,976	64,690	96,106	88,889	69,709	100,824	96,385	74,433	104,867	103,433	79,010	106,664	105,998	81,247
	kW	11.35	11.49	11.81	11.46	11.55	11.87	11.56	11.61	11.90	11.65	11.67	11.93	11.70	11.71	11.94

50TCM - D14 - 12.5 Tons - (50Hz-400V)

Temp (C) Air Entering Condenser (Edb)	Evaporator Air - (L/s)/BPF															
	1699 / 0.041			1982 / 0.058			2265 / 0.088			2549 / 0.111			2784 / 0.131			
	Evaporator Air - EWB (C)															
	17	19	22	17	19	22	17	19	22	17	19	22	17	19	22	
24	TC	40.3	43.2	47.2	41.4	44.2	47.4	42.3	45.1	47.9	43.1	45.6	48.4	44.0	45.8	48.5
	SHC	36.8	30.2	22.9	39.6	32.7	25.5	41.1	35.0	26.6	42.4	37.1	27.6	43.6	38.0	28.1
	kW	6.54	6.57	6.59	6.52	6.56	6.60	6.54	6.56	6.62	6.54	6.57	6.63	6.54	6.57	6.64
29	TC	38.9	42.0	45.3	40.0	43.1	46.4	41.2	43.7	47.0	42.4	44.3	47.4	42.9	44.5	47.6
	SHC	36.2	30.0	23.7	38.9	32.4	25.2	40.5	34.6	26.5	42.0	36.8	27.7	42.5	37.8	28.3
	kW	7.57	7.56	7.58	7.53	7.55	7.58	7.53	7.55	7.60	7.53	7.55	7.61	7.54	7.55	7.62
35	TC	36.7	40.4	43.9	38.4	41.3	44.7	39.8	42.0	45.3	40.9	42.5	45.8	41.4	42.7	46.0
	SHC	35.1	29.4	23.3	37.8	31.8	24.7	39.5	34.1	26.1	40.6	36.3	27.3	41.1	37.3	28.0
	kW	8.54	8.66	8.64	8.62	8.65	8.65	8.65	8.65	8.67	8.64	8.65	8.68	8.63	8.64	8.69
40.6	TC	34.2	38.2	41.9	36.2	39.1	42.8	37.9	39.8	43.4	39.2	40.3	43.8	39.7	40.6	44.0
	SHC	33.5	28.5	22.6	35.9	31.0	24.1	37.6	33.3	25.5	38.8	35.5	26.8	39.3	36.6	27.4
	kW	9.36	9.61	9.63	9.49	9.65	9.63	9.60	9.65	9.64	9.64	9.65	9.65	9.64	9.64	9.65
46	TC	29.9	32.9	37.3	31.7	33.9	38.1	33.3	34.7	38.7	34.6	35.4	39.2	35.1	35.7	39.3
	SHC	30.7	26.6	21.3	32.6	29.1	22.8	34.2	31.5	24.2	35.5	33.8	25.6	36.1	34.9	26.2
	kW	9.69	9.85	10.09	9.79	9.92	10.09	9.88	9.97	10.09	9.97	10.03	10.09	10.01	10.05	10.09
49	TC	29.1	31.8	36.3	30.9	32.8	37.2	32.4	33.5	37.8	33.6	34.2	38.3	34.2	34.6	38.4
	SHC	28.1	24.6	19.7	29.8	26.9	21.1	31.2	29.1	22.5	32.4	31.2	23.8	33.0	32.3	24.4
	kW	10.56	10.72	11.00	10.66	10.79	11.04	10.76	10.84	11.04	10.85	10.89	11.04	10.89	10.92	11.04
52	TC	27.3	29.5	34.0	29.0	30.4	35.0	30.5	31.2	35.6	31.7	31.9	36.1	32.2	32.3	36.3
	SHC	26.5	23.7	19.0	28.2	26.1	20.4	29.5	28.2	21.8	30.7	30.3	23.2	31.3	31.1	23.8
	kW	11.35	11.49	11.81	11.46	11.55	11.87	11.56	11.61	11.90	11.65	11.67	11.93	11.70	11.71	11.94

LEGEND

BPF — Bypass Factor
 Edb — Entering Dry-Bulb
 Ewb — Entering Wet-Bulb
 SHC — Sensible Heat Capacity (1000 Btuh) Gross
Bold, Italics - Standard Ratings

Ldb — Leaving Dry-Bulb
 Lwb — Leaving Wet-Bulb
 TC — Total Capacity (1000 Btuh) Gross
 kW — Compressor Motor Power Input

Notes:

- Direct interpolation is permissible. Do not extrapolate.
- The following formulas may be used.

$$t_{ldb} = t_{edb} - \frac{\text{sensible capacity (Btuh)}}{1.10 \times \text{cfm}}$$

t_{lwb} = Wet-bulb temperature corresponding to enthalpy of air leaving evaporator coil (h_{lwb}).

$$h_{lwb} = h_{ewb} - \frac{\text{total capacity (Btuh)}}{4.5 \times \text{cfm}}$$

Where: h_{ewb} = Enthalpy of air entering evaporator coil.

- Cooling capacities are gross and do not include deductions for indoor fan motor heat.
- Variable Air Volume units will operate down to 70 cfm/ton. Performance at 70 cfm/ton is limited to unloaded operation and may be additionally limited to edb and ewb conditions.

- The SHC is based on 80 F edb temperature of air entering evaporator coil.
 - Below 80 F edb, subtract (corr factor x cfm) from SHC.
 - Above 80 F edb, add (corr factor x cfm) to SHC.

BF	ENTERING AIR DRY-BULB TEMP (F)					
	79	78	77	76	75	under 75
	81	82	83	84	85	over 85
	Correction Factor					
0.05	1.04	2.07	3.11	4.14	5.18	Use formula shown below.*
0.10	0.98	1.96	2.94	3.92	4.90	
0.20	0.87	1.74	2.62	3.49	4.36	
0.30	0.76	1.53	2.29	3.05	3.82	

- Interpolation is permissible.

*Correction Factor = 1.10 x (1 - BF) x (edb - 80).

Fan Performance Table

Unit 50TCM - A07 - 6 Tons - 400V - 50Hz

Air flow Rate (CFM)	0.2			0.4			0.6			0.8			1		
	RPM	KWI	BHP	RPM	KWI	BHP	RPM	KWI	BHP	RPM	KWI	BHP	RPM	KWI	BHP
1800	822	0.48	0.51	927	0.62	0.66	1018	0.76	0.82	1100	0.91	0.98	1174	1.07	1.15
1950	872	0.58	0.62	973	0.74	0.79	1061	0.89	0.95	1140	1.05	1.13	1213	1.21	1.31
2100	923	0.70	0.75	1019	0.86	0.92	1104	1.03	1.10	1182	1.20	1.29	1253	1.36	1.48
2250	974	0.84	0.90	1067	1.01	1.08	1149	1.18	1.27	1224	1.34	1.46	1294	1.53	1.66
2400	1026	0.99	1.06	1115	1.17	1.26	1195	1.36	1.46	1268	1.53	1.66	1336	1.72	1.87
2550	1079	1.17	1.25	1164	1.36	1.46	1241	1.54	1.67	1312	1.73	1.88	1379	1.93	2.10
2700	1132	1.34	1.46	1214	1.54	1.67	1289	1.75	1.90	1358	1.95	2.12	1422	2.16	2.35
2850	1186	1.56	1.69	1264	1.77	1.92	1336	1.98	2.15	1404	2.20	2.39	1467	2.42	2.63

Unit 50TCM - A07 - 6 Tons - 400V - 50Hz (Continued)

Air flow Rate (CFM)	1.2			1.4			1.6			1.8			2		
	RPM	KWI	BHP	RPM	KWI	BHP	RPM	KWI	BHP	RPM	KWI	BHP	RPM	KWI	BHP
1800	1244	1.22	1.33	1308	1.39	1.51	1369	1.57	1.70	1427	1.75	1.90	1438	1.93	2.10
1950	1281	1.37	1.49	1345	1.55	1.68	1405	1.73	1.88	1462	1.92	2.09	1517	2.12	2.30
2100	1320	1.54	1.67	1382	1.72	1.87	1441	1.92	2.08	1498	2.11	2.29	1552	2.31	2.51
2250	1359	1.72	1.87	1420	1.92	2.08	1479	2.11	2.29	1534	2.31	2.51	1587	2.52	2.74
2400	1400	1.92	2.09	1460	2.13	2.31	1517	2.33	2.53	1572	2.54	2.76	1624	2.75	2.99
2550	1441	2.15	2.33	1500	2.35	2.55	1557	2.57	2.79	1610	2.79	3.03	1662	3.01	3.27
2700	1483	2.39	2.59	1541	2.61	2.83	1597	2.83	3.07	1650	3.06	3.32	1701	3.29	3.57
2850	1527	2.64	2.87	1583	2.87	3.12	1638	3.10	3.37	1690	3.34	3.63	-	-	-

Unit 50TCM - D08 - 7.5 Tons - 400V - 50Hz

Air flow Rate (CFM)	0.2			0.4			0.6			0.8			1		
	RPM	KWI	BHP	RPM	KWI	BHP	RPM	KWI	BHP	RPM	KWI	BHP	RPM	KWI	BHP
2250	485	0.49	0.53	561	0.68	0.73	627	0.89	0.95	686	1.11	1.19	740	0.91	0.99
2438	513	0.60	0.64	585	0.79	0.85	649	1.01	1.08	706	1.24	1.33	759	1.04	1.13
2625	541	0.71	0.76	610	0.92	0.99	671	1.15	1.23	727	1.37	1.49	778	1.18	1.28
2813	569	0.84	0.90	636	1.06	1.14	694	1.30	1.39	749	1.53	1.66	799	1.33	1.44
3000	599	0.99	1.06	661	1.22	1.31	718	1.46	1.58	770	1.71	1.86	820	1.49	1.62
3188	628	1.15	1.23	688	1.40	1.50	743	1.64	1.78	794	1.91	2.07	842	1.67	1.81
3375	657	1.33	1.43	715	1.57	1.71	769	1.84	2.00	818	2.13	2.31	865	1.86	2.02
3563	687	1.54	1.65	743	1.79	1.94	794	2.07	2.25	843	2.36	2.56	887	2.66	2.89
3750	717	1.74	1.89	770	2.03	2.20	821	2.32	2.52	867	2.62	2.84	911	2.93	3.18

Unit 50TCM - D08 - 7.5 Tons - 400V - 50Hz (Continued)

Air flow Rate (CFM)	1.2			1.4			1.6			1.8			2		
	RPM	KWI	BHP	RPM	KWI	BHP	RPM	KWI	BHP	RPM	KWI	BHP	RPM	KWI	BHP
2250	790	1.57	1.71	838	1.83	1.99	882	2.11	2.29	924	2.39	2.59	964	2.69	2.92
2438	808	1.72	1.87	854	1.99	2.16	898	2.27	2.46	940	2.56	2.78	979	2.86	3.11
2625	827	1.88	2.04	872	2.16	2.34	915	2.45	2.66	956	2.74	2.98	996	3.06	3.32
2813	846	2.06	2.24	890	2.35	2.55	933	2.64	2.87	973	2.96	3.21	1012	3.27	3.55
3000	866	2.27	2.46	910	2.56	2.78	951	2.86	3.11	991	3.18	3.45	1029	3.50	3.80
3188	887	2.48	2.69	930	2.78	3.02	971	3.09	3.36	1010	3.43	3.72	1047	3.76	4.08
3375	908	2.72	2.95	950	3.03	3.29	990	3.35	3.64	1029	3.68	4.00	1066	4.03	4.38
3563	931	2.97	3.23	972	3.30	3.58	1011	3.63	3.94	1049	3.98	4.32	1085	4.33	4.70
3750	954	3.26	3.54	994	3.59	3.90	1034	3.93	4.27	1069	4.28	4.65	-	-	-

Legend:

Normal Font - Field Installed Drive Package

Bold Font - Standard Drive Package + Standard Motor.

Italics Font - Medium Drive Package + Medium Static Motor.

Bold , Italics Font - High Drive Package + High Static Motor.

RPM - Revolutions Per Minute

KWI - Kilo Watts Input to Motor

BHP - Brake Horsepower Input to Fan

CFM - Cubic Feet per Minute

in.wg - Inch Water Gage

Notes:

- Do not adjust motor rpm such that motor maximum bhp and/or watts is exceeded at the maximum operatin cfm.
- Static Pressure (i.e Filters) must be added to external static pressure before entering fan performance table.
- Interpolation is permissible. Do not extrapolate.
- Fan performance is based on wet coils, clean filters and casing losses.
- Extensive motor and drive testing on these units ensures that the full brake horsepower and watts range of the motor can be utilized with confidence. Using your fan motors up to the watts or bhp rating shown will not result in nuisance tripping or premature motor failure. Unit warranty will not be affected.
- Bold data shows the range of air flow rate for unit management system, other rpms require field-supplied drive.
- Use of field-supplied motor may affect wiring size. Contact your Carrier representative for details.
- Conversion - Bhp to KWI

$$KWI = \frac{Bhp \times 0.746}{\text{Motor efficiency}}$$

Fan Performance Table (Continued)

Unit 50TCM - D09 - 8.5 Tons - 400V - 50Hz

Air flow Rate (CFM)	0.2			0.4			0.6			0.8			1		
	RPM	KWI	BHP	RPM	KWI	BHP	RPM	KWI	BHP	RPM	KWI	BHP	RPM	KWI	BHP
2550	477	0.40	0.43	556	0.53	0.57	624	0.66	0.71	685	0.79	0.85	742	0.91	0.99
2763	503	0.48	0.52	578	0.62	0.67	644	0.76	0.82	704	0.90	0.97	759	1.04	1.13
2975	529	0.58	0.62	601	0.74	0.79	665	0.89	0.95	724	1.04	1.11	777	1.18	1.28
3188	556	0.69	0.74	625	0.86	0.92	687	1.02	1.09	744	1.16	1.26	796	1.33	1.44
3400	583	0.82	0.88	650	0.99	1.06	710	1.16	1.24	765	1.32	1.43	816	1.49	1.62
3613	611	0.96	1.03	675	1.14	1.22	733	1.32	1.42	787	1.48	1.61	836	1.67	1.81
3825	639	1.11	1.19	701	1.31	1.40	757	1.48	1.61	809	1.67	1.81	857	1.86	2.02
3950	668	1.29	1.38	727	1.49	1.60	781	1.67	1.81	832	1.87	2.03	879	2.07	2.25
4250	696	1.47	1.58	753	1.67	1.81	806	1.88	2.04	855	2.09	2.27	901	2.30	2.50

Unit 50TCM - D09 - 8.5 Tons - 400V - 50Hz (Continued)

Air flow Rate (CFM)	1.2			1.4			1.6			1.8			2		
	RPM	KWI	BHP	RPM	KWI	BHP	RPM	KWI	BHP	RPM	KWI	BHP	RPM	KWI	BHP
2550	794	1.05	1.14	842	1.19	1.29	888	1.33	1.44	932	1.46	1.59	973	1.61	1.75
2763	810	1.18	1.28	858	1.33	1.44	903	1.47	1.60	946	1.63	1.77	987	1.78	1.93
2975	827	1.33	1.44	874	1.48	1.61	919	1.64	1.78	961	1.80	1.95	1001	1.96	2.13
3188	845	1.49	1.62	891	1.65	1.79	935	1.82	1.98	977	1.99	2.16	1017	2.16	2.34
3400	864	1.66	1.80	909	1.83	1.99	952	2.01	2.18	993	2.19	2.38	1033	2.37	2.57
3613	883	1.85	2.01	928	2.04	2.21	970	2.22	2.41	1010	2.40	2.61	1049	2.60	2.82
3825	903	2.05	2.23	947	2.25	2.44	988	2.44	2.65	1028	2.64	2.87	1066	2.84	3.08
3950	924	2.27	2.47	967	2.49	2.70	1008	2.69	2.92	1047	2.89	3.14	1084	3.10	3.37
4250	945	2.51	2.73	987	2.74	2.97	1027	2.95	3.20	1066	3.16	3.43	1103	3.38	3.67

Unit 50TCM - D12 - 10 Tons - 400V - 50Hz

Air flow Rate (CFM)	0.2			0.4			0.6			0.8			1		
	RPM	KWI	BHP	RPM	KWI	BHP	RPM	KWI	BHP	RPM	KWI	BHP	RPM	KWI	BHP
3000	556	0.61	0.65	623	0.75	0.80	684	0.89	0.95	738	1.04	1.11	789	1.17	1.26
3250	590	0.74	0.79	655	0.90	0.96	713	1.05	1.13	766	1.20	1.29	815	1.36	1.46
3500	625	0.90	0.96	687	1.06	1.14	742	1.23	1.32	794	1.40	1.50	841	1.55	1.68
3750	661	1.08	1.16	719	1.26	1.35	773	1.44	1.54	822	1.61	1.73	869	1.78	1.93
4000	697	1.28	1.37	753	1.47	1.58	804	1.67	1.79	852	1.86	1.99	897	2.03	2.20
4250	733	1.51	1.62	787	1.72	1.84	836	1.92	2.06	883	2.13	2.28	926	2.29	2.49
4500	770	1.76	1.89	821	1.99	2.13	869	2.17	2.36	914	2.39	2.59	956	2.60	2.82

Unit 50TCM - D12 - 10 Tons - 400V - 50Hz (Continued)

Air flow Rate (CFM)	1.2			1.4			1.6			1.8			2		
	RPM	KWI	BHP	RPM	KWI	BHP	RPM	KWI	BHP	RPM	KWI	BHP	RPM	KWI	BHP
3000	836	1.32	1.42	881	1.45	1.57	923	1.59	1.73	963	1.74	1.89	1001	1.89	2.05
3250	861	1.50	1.63	904	1.65	1.79	945	1.81	1.96	985	1.96	2.13	1023	2.12	2.30
3500	886	1.71	1.86	929	1.88	2.04	969	2.04	2.22	1008	2.21	2.40	1045	2.38	2.58
3750	912	1.95	2.12	954	2.13	2.31	994	2.30	2.50	1031	2.49	2.70	1068	2.66	2.89
4000	940	2.21	2.40	980	2.40	2.61	1019	2.59	2.81	1056	2.78	3.02	1092	2.97	3.22
4250	968	2.50	2.71	1007	2.70	2.93	1045	2.90	3.15	1081	3.09	3.36	1117	3.30	3.58
4500	996	2.81	3.05	1035	3.02	3.28	1072	3.23	3.51	1108	3.44	3.74	1142	3.66	3.97

Legend:

Normal Font - Field Installed Drive Package

Bold Font - Standard Drive Package + Standard Motor.

Italics Font - Medium Drive Package + Medium Static Motor.

Bold, Italics Font - High Drive Package + High Static Motor.

RPM - Revolutions Per Minute

KWI - Kilo Watts Input to Motor

BHP - Brake Horsepower Input to Fan

CFM - Cubic Feet per Minute

in.wg - Inch Water Gage

Notes:

- Do not adjust motor rpm such that motor maximum bhp and/or watts is exceeded at the maximum operatin cfm.
- Static Pressure (i.e Filters) must be added to external static pressure before entering fan performance table.
- Interpolation is permissible. Do not extrapolate.
- Fan performance is based on wet coils, clean filters and casing losses.
- Extensive motor and drive testing on these units ensures that the full brake horsepower and watts range of the motor can be utilized with confidence. Using your fan motors up to the watts or bhp rating shown will not result in nuisance tripping or premature motor failure. Unit warranty will not be affected.
- Bold data shows the range of air flow rate for unit management system, other rpms require field-supplied drive.
- Use of field-supplied motor may affect wiring size. Contact your Carrier representative for details.
- Conversion - Bhp to KWI

$$KWI = \frac{Bhp \times 0.746}{\text{Motor efficiency}}$$

Fan Performance Table (Continued)

Unit 50TCM - D14 - 12.5 Tons - 400V - 50Hz

Air flow Rate (CFM)	0.2			0.4			0.6			0.8			1		
	RPM	KWI	BHP	RPM	KWI	BHP	RPM	KWI	BHP	RPM	KWI	BHP	RPM	KWI	BHP
3700	621	0.95	1.03	679	1.11	1.21	734	1.29	1.40	786	1.46	1.59	837	1.65	1.79
4063	663	1.18	1.28	717	1.35	1.47	769	1.54	1.67	818	1.73	1.88	866	1.92	2.09
4375	706	1.44	1.56	757	1.63	1.77	805	1.82	1.98	852	2.03	2.20	897	2.24	2.43
4688	749	1.74	1.89	797	1.94	2.11	843	2.16	2.34	887	2.37	2.57	930	2.59	2.81
5000	793	2.08	2.26	838	2.30	2.50	881	2.52	2.74	923	2.74	2.98	965	2.97	3.23
5313	837	2.48	2.69	880	2.70	2.93	921	2.94	3.19	961	3.17	3.44	1000	3.42	3.71
5700	882	2.91	3.16	922	3.15	3.42	961	3.39	3.68	999	3.64	3.95	1037	3.87	4.20

Unit 50TCM - D14 - 12.5 Tons - 400V - 50Hz (Continued)

Air flow Rate (CFM)	1.2			1.4			1.6			1.8			2		
	RPM	KWI	BHP	RPM	KWI	BHP	RPM	KWI	BHP	RPM	KWI	BHP	RPM	KWI	BHP
3700	885	1.83	1.99	932	2.03	2.20	978	2.23	2.42	1022	2.43	2.64	1065	2.63	2.86
4063	912	2.13	2.31	957	2.33	2.53	1001	2.53	2.75	1043	2.74	2.98	1084	2.97	3.22
4375	941	2.45	2.66	984	2.66	2.89	1026	2.88	3.13	1066	3.10	3.37	1106	3.33	3.62
4688	972	2.81	3.05	1013	3.03	3.29	1053	3.26	3.54	1092	3.50	3.80	1130	3.74	4.06
5000	1005	3.21	3.49	1044	3.44	3.74	1082	3.69	4.01	1119	3.93	4.27	1156	4.19	4.55
5313	1038	3.66	3.97	1076	3.87	4.20	1113	4.16	4.52	-	-	-	-	-	-
5700	1073	4.15	4.51	-	-	-	-	-	-	-	-	-	-	-	-

Legend:

Normal Font - Field Installed Drive Package

Bold Font - Standard Drive Package + Standard Motor.

Italics Font - Medium Drive Package + Medium Static Motor.

Bold , Italics Font - High Drive Package + High Static Motor.

RPM - Revolutions Per Minute

KWI - Kilo Watts Input to Motor

BHP - Brake Horsepower Input to Fan

CFM - Cubic Feet per Minute

in.wg - Inch Water Gage

Notes:

1. Do not adjust motor rpm such that motor maximum bhp and/or watts is exceeded at the maximum operatin cfm.
2. Static Pressure (i.e Filters) must be added to external static pressure before entering fan performance table.
3. Interpolation is permissible. Do not extrapolate.
4. Fan performance is based on wet coils, clean filters and casing loses.
5. Extensive motor and drive testing on these units ensures that the full brake horsepower and watts range of the motor can be utilized with confidence. Using your fan motors up to the watts or bhp rating shown will not result in nuisance tripping or premature motor failure. Unit warranty will not be affected.
6. Bold data shows the range of air flow rate for unit management system, other rpms require field-supplied drive.
7. Use of field-supplied motor may affect wiring size. Contact your Carrier representative for details.
8. Conversion - Bhp to KWI

$$KWl = \frac{Bhp \times 0.746}{\text{Motor efficiency}}$$

Fan RPM at Motor Pulley Settings

Freq.	Unit 50TCM	Drive Package	MOTOR PULLEY TURNS OPEN - ENGLISH										
			0	1/2	1	1 1/2	2	2 1/2	3	3 1/2	4	4 1/2	5
50Hz	A07	Standard Static	1211	1176	1140	1104	1069	1033	998	962	926	891	855
		Medium Static	1393	1362	1330	1298	1267	1235	1203	1172	1140	1108	1077
		High Static	1568	1532	1496	1461	1425	1389	1354	1318	1283	1247	1211
	D08	Standard Static	808	784	760	736	713	689	665	641	618	594	570
		Medium Static	896	875	855	835	814	794	774	753	733	713	692
		High Static	1140	1114	1088	1062	1036	1010	985	959	933	907	881
	D09	Standard Static	808	784	760	736	713	689	665	641	618	594	570
		Medium Static	896	875	855	835	814	794	774	753	733	713	692
		High Static	1140	1114	1088	1062	1036	1010	985	959	933	907	881
	D12	Standard Static	808	784	760	736	713	689	665	641	618	594	570
		Medium Static	1045	1021	998	974	950	926	903	879	855	831	808
		High Static	1160	1140	1120	1099	1079	1059	1038	1018	998	977	957
	D14	Standard Static	903	879	855	831	808	784	760	736	713	689	665
		Medium Static	1015	998	980	962	944	926	908	891	873	855	837
		High Static	1160	1140	1120	1099	1079	1059	1038	1018	998	977	957

Freq.	Unit 50TCM	Drive Package	MOTOR PULLEY TURNS OPEN - SI										
			0	1/2	1	1 1/2	2	2 1/2	3	3 1/2	4	4 1/2	5
50Hz	A07	Standard Static	20.2	19.6	19.0	18.4	17.8	17.2	16.6	16.0	15.4	14.8	14.3
		Medium Static	23.2	22.7	22.2	21.6	21.1	20.6	20.1	19.5	19.0	18.5	17.9
		High Static	26.1	25.5	24.9	24.3	23.8	23.2	22.6	22.0	21.4	20.8	20.2
	D08	Standard Static	13.5	13.1	12.7	12.3	11.9	11.5	11.1	10.7	10.3	9.9	9.5
		Medium Static	14.9	14.6	14.3	13.9	13.6	13.2	12.9	12.6	12.2	11.9	11.5
		High Static	19.0	18.6	18.1	17.7	17.3	16.8	16.4	16.0	15.5	15.1	14.7
	D09	Standard Static	13.5	13.1	12.7	12.3	11.9	11.5	11.1	10.7	10.3	9.9	9.5
		Medium Static	14.9	14.6	14.3	13.9	13.6	13.2	12.9	12.6	12.2	11.9	11.5
		High Static	19.0	18.6	18.1	17.7	17.3	16.8	16.4	16.0	15.5	15.1	14.7
	D12	Standard Static	13.5	13.1	12.7	12.3	11.9	11.5	11.1	10.7	10.3	9.9	9.5
		Medium Static	17.4	17.0	16.6	16.2	15.8	15.4	15.0	14.6	14.3	13.9	13.5
		High Static	19.3	19.0	18.7	18.3	18.0	17.6	17.3	17.0	16.6	16.3	15.9
	D14	Standard Static	15.0	14.6	14.3	13.9	13.5	13.1	12.7	12.3	11.9	11.5	11.1
		Medium Static	16.9	16.6	16.3	16.0	15.7	15.4	15.1	14.8	14.5	14.3	14.0
		High Static	19.3	19.0	18.7	18.3	18.0	17.6	17.3	17.0	16.6	16.3	15.9

Bold, Italics RPM is the factory setting . In range of +/- 5 %.

The standard belt size may not cover all the above range. Other RPMs require field supplied drive package.

Sound Rating Data

Unit 50TCM	Cooling Stages	Unit Sound (dB) - Based on cooling mode								
		A-Weighted	63	125	250	500	1000	2000	4000	8000
A07	1	85.3	106.5	85.7	83	81.8	79.1	73.6	70.1	65.4
D08	2	84.4	104.5	84.4	82.7	81.1	78.6	73.2	69.5	65.1
D09	2	85.7	106.5	85.2	83.6	82.1	79.7	74.2	70.8	66.9
D12	2	90.2	95.3	88.7	87.5	86.1	85.2	83.1	79.5	76.2
D14	2	92.0	95.4	90.3	89.5	88.6	87.2	83.6	82.1	78.1

dB – Decibel

NOTES:

1. Measurements are expressed in terms of sound power. Do not compare these values to sound pressure values because sound pressure accounts for specific environment factors which do not match individual applications. Sound power values are independent of the environment and therefore more accurate.

2. A-Weighted sound ratings filter out very high and very low frequencies, to better approximate the response of an "average" human ear.

Electrical Data

50TCM			Compressor				OFM			IFM		Electric Heater			MCA	MOCP
Unit Size	Drive package Indoor Motor	Power Supply V / Ph / Hz	No.1		No.2		Qty	HP	FLA	HP	FLA	Heater P.N	Application (KW)	FLA		
			RLA	LRA	RLA	LRA										
A07	Standard	400/3/50	10.6	74.0	-	-	1	1/3	2.8	1.4	2.6	-	-	-	18.7	25
			10.6	74.0	-	-	1	1/3	2.8	1.4	2.6	CRHEATER106A00	4.2	6.0	18.7	25
			10.6	74.0	-	-	1	1/3	2.8	1.4	2.6	CRHEATER108A00	8.0	11.5	18.7	25
			10.6	74.0	-	-	1	1/3	2.8	1.4	2.6	CRHEATER109A00	9.7	14.0	20.8	25
			10.6	74.0	-	-	1	1/3	2.8	1.4	2.6	CRHEATER108A00,108A00	16.0	23.1	32.1	35
			10.6	74.0	-	-	1	1/3	2.8	1.4	2.6	CRHEATER108A00,109A00	17.7	25.6	35.3	40
	Medium		10.6	74.0	-	-	1	1/3	2.8	2.4	3.4	-	-	-	19.5	30
			10.6	74.0	-	-	1	1/3	2.8	2.4	3.4	CRHEATER106A00	4.2	6.0	19.5	30
			10.6	74.0	-	-	1	1/3	2.8	2.4	3.4	CRHEATER108A00	8.0	11.5	19.5	30
			10.6	74.0	-	-	1	1/3	2.8	2.4	3.4	CRHEATER109A00	9.7	14.0	21.8	30
			10.6	74.0	-	-	1	1/3	2.8	2.4	3.4	CRHEATER108A00,108A00	16.0	23.1	33.1	35
			10.6	74.0	-	-	1	1/3	2.8	2.4	3.4	CRHEATER108A00,109A00	17.7	25.6	36.3	40
	High		10.6	74.0	-	-	1	1/3	2.8	3.1	4.4	-	-	-	20.5	30
			10.6	74.0	-	-	1	1/3	2.8	3.1	4.4	CRHEATER106A00	4.2	6.0	20.5	30
			10.6	74.0	-	-	1	1/3	2.8	3.1	4.4	CRHEATER108A00	8.0	11.5	20.5	30
			10.6	74.0	-	-	1	1/3	2.8	3.1	4.4	CRHEATER109A00	9.7	14.0	23.0	30
			10.6	74.0	-	-	1	1/3	2.8	3.1	4.4	CRHEATER108A00,108A00	16.0	23.1	34.4	35
			10.6	74.0	-	-	1	1/3	2.8	3.1	4.4	CRHEATER108A00,109A00	17.7	25.6	37.5	40
D08	Standard	400/3/50	6.8	43.0	6.1	43.0	2	1/3	1.8	2.0	2.6	-	-	-	19.9	25
			6.8	43.0	6.1	43.0	2	1/3	1.8	2.0	2.6	CRHEATER116A00	9.7	13.9	20.6	25
			6.8	43.0	6.1	43.0	2	1/3	1.8	2.0	2.6	CRHEATER113A00	11.5	16.5	23.9	25
			6.8	43.0	6.1	43.0	2	1/3	1.8	2.0	2.6	CRHEATER114A00	19.3	27.9	38.1	40
			6.8	43.0	6.1	43.0	2	1/3	1.8	2.0	2.6	CRHEATER115A00	22.9	33.1	44.6	45
			6.8	43.0	6.1	43.0	2	1/3	1.8	2.0	2.6	CRHEATER114A00,116A00	29.0	41.8	55.5	60
	Medium		6.8	43.0	6.1	43.0	2	1/3	1.8	2.4	3.4	-	-	-	20.7	25
			6.8	43.0	6.1	43.0	2	1/3	1.8	2.4	3.4	CRHEATER116A00	9.7	13.9	21.6	25
			6.8	43.0	6.1	43.0	2	1/3	1.8	2.4	3.4	CRHEATER113A00	11.5	16.5	24.9	25
			6.8	43.0	6.1	43.0	2	1/3	1.8	2.4	3.4	CRHEATER114A00	19.3	27.9	39.1	40
			6.8	43.0	6.1	43.0	2	1/3	1.8	2.4	3.4	CRHEATER115A00	22.9	33.1	45.6	50
			6.8	43.0	6.1	43.0	2	1/3	1.8	2.4	3.4	CRHEATER114A00,116A00	29.0	41.8	56.5	60
	High		6.8	43.0	6.1	43.0	2	1/3	1.8	3.9	7.4	-	-	-	24.7	30
			6.8	43.0	6.1	43.0	2	1/3	1.8	3.9	7.4	CRHEATER116A00	9.7	13.9	26.6	30
			6.8	43.0	6.1	43.0	2	1/3	1.8	3.9	7.4	CRHEATER113A00	11.5	16.5	29.9	30
			6.8	43.0	6.1	43.0	2	1/3	1.8	3.9	7.4	CRHEATER114A00	19.3	27.9	44.1	45
			6.8	43.0	6.1	43.0	2	1/3	1.8	3.9	7.4	CRHEATER115A00	22.9	33.1	50.6	60
			6.8	43.0	6.1	43.0	2	1/3	1.8	3.9	7.4	CRHEATER114A00,116A00	29.0	41.8	61.5	70
D09	Standard	400/3/50	7.6	51.5	6.2	52.0	2	1/3	1.8	2.0	2.6	-	-	-	21.9	25
			7.6	51.5	6.2	52.0	2	1/3	1.8	2.0	2.6	CRHEATER116A00	9.7	13.9	21.9	25
			7.6	51.5	6.2	52.0	2	1/3	1.8	2.0	2.6	CRHEATER113A00	11.5	16.5	23.9	25
			7.6	51.5	6.2	52.0	2	1/3	1.8	2.0	2.6	CRHEATER114A00	19.3	27.9	38.1	40
			7.6	51.5	6.2	52.0	2	1/3	1.8	2.0	2.6	CRHEATER115A00	22.9	33.1	44.6	45
			7.6	51.5	6.2	52.0	2	1/3	1.8	2.0	2.6	CRHEATER114A00,116A00	29.0	41.8	55.5	60
	Medium		7.6	51.5	6.2	52.0	2	1/3	1.8	2.4	3.4	-	-	-	22.7	30
			7.6	51.5	6.2	52.0	2	1/3	1.8	2.4	3.4	CRHEATER116A00	9.7	13.9	22.7	30
			7.6	51.5	6.2	52.0	2	1/3	1.8	2.4	3.4	CRHEATER113A00	11.5	16.5	24.9	30
			7.6	51.5	6.2	52.0	2	1/3	1.8	2.4	3.4	CRHEATER114A00	19.3	27.9	39.1	40
			7.6	51.5	6.2	52.0	2	1/3	1.8	2.4	3.4	CRHEATER115A00	22.9	33.1	45.6	50
			7.6	51.5	6.2	52.0	2	1/3	1.8	2.4	3.4	CRHEATER114A00,116A00	29.0	41.8	56.5	60
	High		7.6	51.5	6.2	52.0	2	1/3	1.8	3.9	7.4	-	-	-	26.7	30
			7.6	51.5	6.2	52.0	2	1/3	1.8	3.9	7.4	CRHEATER116A00	9.7	13.9	26.7	30
			7.6	51.5	6.2	52.0	2	1/3	1.8	3.9	7.4	CRHEATER113A00	11.5	16.5	29.9	30
			7.6	51.5	6.2	52.0	2	1/3	1.8	3.9	7.4	CRHEATER114A00	19.3	27.9	44.1	45
			7.6	51.5	6.2	52.0	2	1/3	1.8	3.9	7.4	CRHEATER115A00	22.9	33.1	50.6	60
			7.6	51.5	6.2	52.0	2	1/3	1.8	3.9	7.4	CRHEATER114A00,116A00	29.0	41.8	61.5	70

Electrical Data (Continued)

50TCM			Compressor				OFM			IFM		Electric Heater			MCA	MOCP
Unit Size	Drive package Indoor Motor	Power Supply V / Ph / Hz	No.1		No.2		Qty	HP	FLA	HP	FLA	Heater P.N	Application (KW)	FLA		
			RLA	LRA	RLA	LRA										
D12	Standard	400/3/50	7.8	51.5	7.8	51.5	1	1	3.4	2.0	2.6	-	-	-	23.6	30
			7.8	51.5	7.8	51.5	1	1	3.4	2.0	2.6	CRHEATER116A00	9.7	13.9	23.6	30
			7.8	51.5	7.8	51.5	1	1	3.4	2.0	2.6	CRHEATER113A00	11.5	16.5	23.9	30
			7.8	51.5	7.8	51.5	1	1	3.4	2.0	2.6	CRHEATER114A00	19.3	27.9	38.1	40
			7.8	51.5	7.8	51.5	1	1	3.4	2.0	2.6	CRHEATER115A00	22.9	33.1	44.6	45
			7.8	51.5	7.8	51.5	1	1	3.4	2.0	2.6	CRHEATER114A00,116A00	29	41.8	55.5	60
	Medium		7.8	51.5	7.8	51.5	1	1	3.4	3.1	4.4	-	-	-	25.4	30
			7.8	51.5	7.8	51.5	1	1	3.4	3.1	4.4	CRHEATER116A00	9.7	13.9	25.4	30
			7.8	51.5	7.8	51.5	1	1	3.4	3.1	4.4	CRHEATER113A00	11.5	16.5	26.1	30
			7.8	51.5	7.8	51.5	1	1	3.4	3.1	4.4	CRHEATER114A00	19.3	27.9	40.4	45
			7.8	51.5	7.8	51.5	1	1	3.4	3.1	4.4	CRHEATER115A00	22.9	33.1	46.9	50
			7.8	51.5	7.8	51.5	1	1	3.4	3.1	4.4	CRHEATER114A00,116A00	29	41.8	57.8	60
	High		7.8	51.5	7.8	51.5	1	1	3.4	4.2	9.8	-	-	-	30.8	35
			7.8	51.5	7.8	51.5	1	1	3.4	4.2	9.8	CRHEATER116A00	9.7	13.9	30.8	35
			7.8	51.5	7.8	51.5	1	1	3.4	4.2	9.8	CRHEATER113A00	11.5	16.5	32.9	35
			7.8	51.5	7.8	51.5	1	1	3.4	4.2	9.8	CRHEATER114A00	19.3	27.9	47.1	50
			7.8	51.5	7.8	51.5	1	1	3.4	4.2	9.8	CRHEATER115A00	22.9	33.1	53.6	60
			7.8	51.5	7.8	51.5	1	1	3.4	4.2	9.8	CRHEATER114A00,116A00	29	41.8	64.5	70
D14	Standard	400/3/50	9.7	64.0	10.6	74.0	1	1	3.4	2.4	3.4	-	-	-	29.5	35
			9.7	64.0	10.6	74.0	1	1	3.4	2.4	3.4	CRHEATER116A00	9.7	13.9	29.5	35
			9.7	64.0	10.6	74.0	1	1	3.4	2.4	3.4	CRHEATER113A00	11.5	16.5	29.5	35
			9.7	64.0	10.6	74.0	1	1	3.4	2.4	3.4	CRHEATER114A00	19.3	27.9	39.1	40
			9.7	64.0	10.6	74.0	1	1	3.4	2.4	3.4	CRHEATER115A00	22.9	33.1	45.6	50
			9.7	64.0	10.6	74.0	1	1	3.4	2.4	3.4	CRHEATER114A00,116A00	29	41.8	56.5	60
	Medium		9.7	64.0	10.6	74.0	1	1	3.4	3.9	7.4	-	-	-	33.5	40
			9.7	64.0	10.6	74.0	1	1	3.4	3.9	7.4	CRHEATER116A00	9.7	13.9	33.5	40
			9.7	64.0	10.6	74.0	1	1	3.4	3.9	7.4	CRHEATER113A00	11.5	16.5	33.5	40
			9.7	64.0	10.6	74.0	1	1	3.4	3.9	7.4	CRHEATER114A00	19.3	27.9	44.1	45
			9.7	64.0	10.6	74.0	1	1	3.4	3.9	7.4	CRHEATER115A00	22.9	33.1	50.6	60
			9.7	64.0	10.6	74.0	1	1	3.4	3.9	7.4	CRHEATER114A00,116A00	29	41.8	61.5	70
	High		9.7	64.0	10.6	74.0	1	1	3.4	4.2	9.8	-	-	-	35.9	45
			9.7	64.0	10.6	74.0	1	1	3.4	4.2	9.8	CRHEATER116A00	9.7	13.9	35.9	45
			9.7	64.0	10.6	74.0	1	1	3.4	4.2	9.8	CRHEATER113A00	11.5	16.5	35.9	45
			9.7	64.0	10.6	74.0	1	1	3.4	4.2	9.8	CRHEATER114A00	19.3	27.9	47.1	50
			9.7	64.0	10.6	74.0	1	1	3.4	4.2	9.8	CRHEATER115A00	22.9	33.1	53.6	60
			9.7	64.0	10.6	74.0	1	1	3.4	4.2	9.8	CRHEATER114A00,116A00	29	41.8	64.5	70

Legend and Notes for Electrical Data Table

- FLA - Full Load Amps
- IFM - Indoor (Evaporator) Fan Motor
- LRA - Locked Rotor Amps
- MCA - Minimum Circuit Amps
- Minimum Voltage: 360V , Maximum Voltage: 440V on 400/3/50
- OFM - Outdoor (Condenser) Fan Motor
- RLA - Rated Load Amps
- NOM - Nominal
- MOCP - Maximum Overcurrent Protection

Unbalanced 3-Phase Supply Voltage

Never operate a motor where phase imbalance in supply voltage is greater than 2%.

Use the following formula to determine the percentage of voltage imbalance

$$= 100 \times \frac{\text{Maximum Deviation From Average Voltage}}{\text{Average Voltage}}$$

Determine maximum deviation from average voltage.

- (AB) 397 - 392 =5v
- (BC) 404 - 397 =7v
- (AC) 457 - 397 =2v

Example: Supply Voltage is 400V - 3ph - 60Hz

AB = 392v	Average	
BC = 404v	Voltage =	
AC = 395v	=	

Maximum Deviation is 7v.

Determine Percentage Voltage Imbalance.

$$\% \text{ Voltage Imbalance} = 100 \times \frac{7}{397} = 1.76\%$$

This amount of phase imbalance is satisfactory as it is below the maximum allowable 2%

IMPORTANT: If the supply voltage phase imbalance is more than 2% contact your local electric utility company

Typical Wiring Schematic 50TCMD 08-09 400V

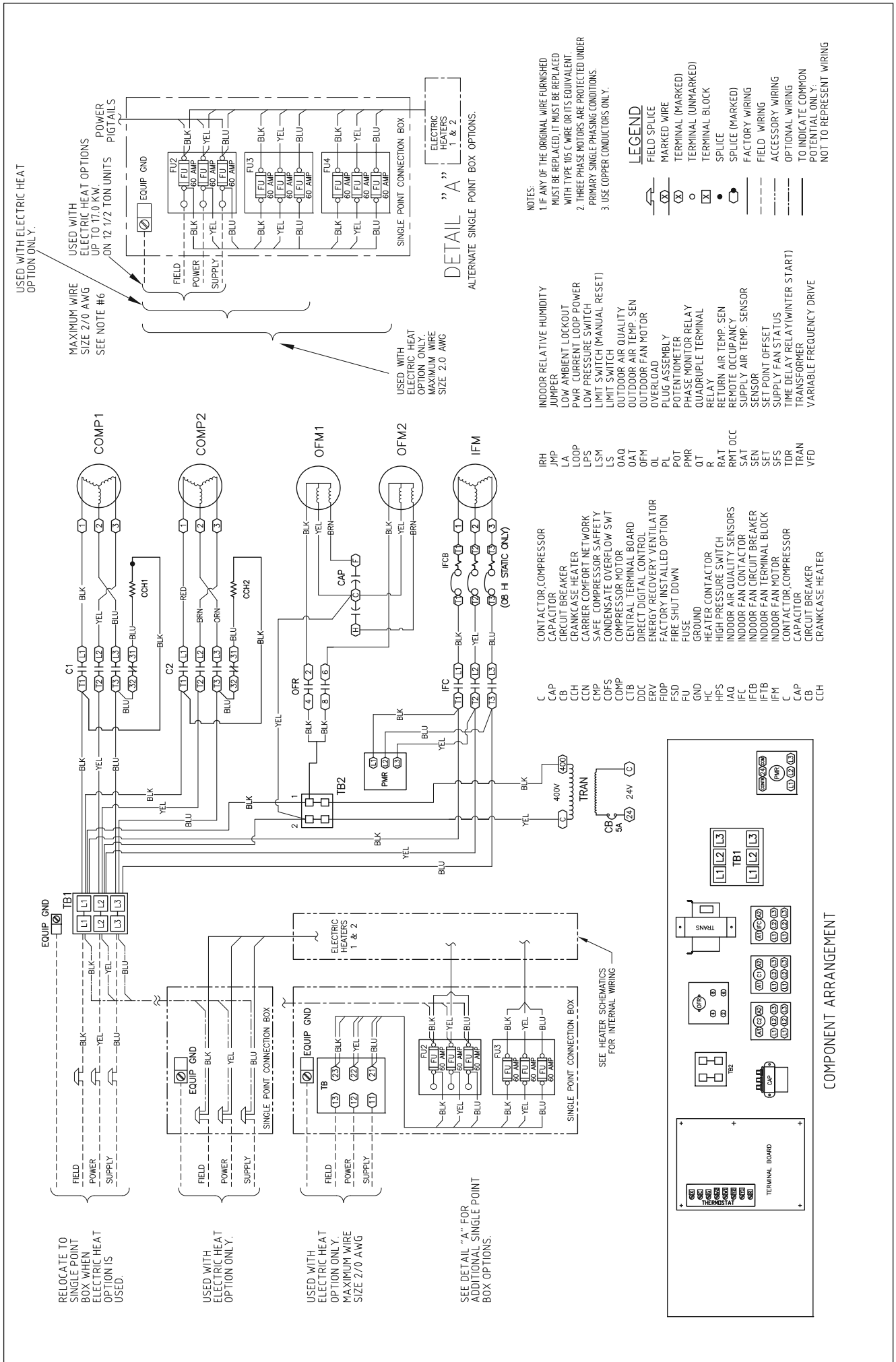

Typical Wiring Schematic 50TCMD 12-14 400V

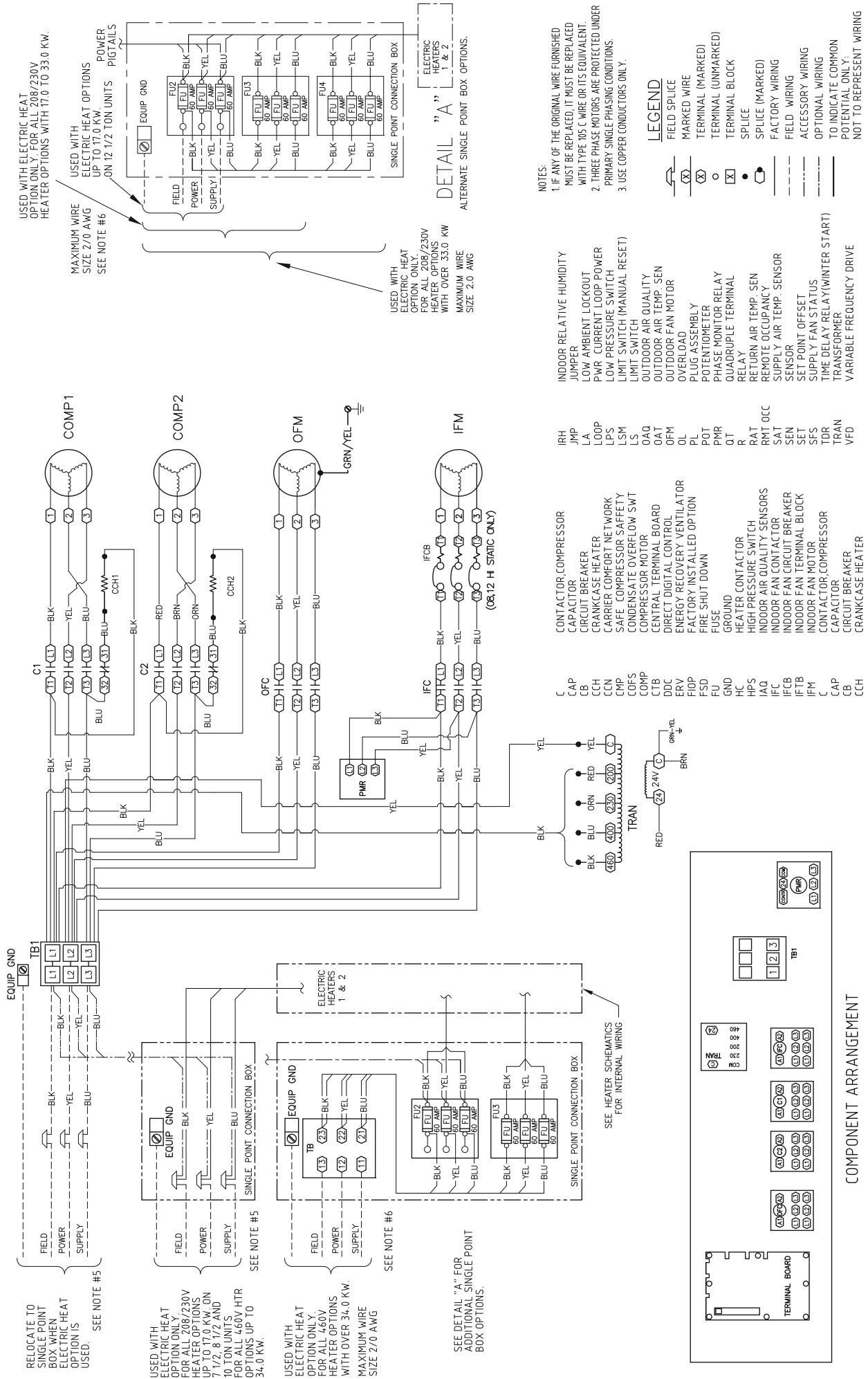

- LEGEND**
- FIELD SPLICE
 - MARKED WIRE
 - TERMINAL (MARKED)
 - TERMINAL (UNMARKED)
 - SPLICE
 - FACTORY (MARKED)
 - FACTORY WIRING
 - FIELD WIRING
 - ACCESSORY WIRING
 - OPTIONAL WIRING
 - TO INDICATE COMMON
 - POTENTIAL ONLY
 - NOT TO REPRESENT WIRING

- NOTES:**
1. IF ANY OF THE ORIGINAL WIRE FURNISHED WITH TYPE 'A' WIRE OR ITS EQUIVALENT MUST BE REPLACED, IT MUST BE REPLACED WITH TYPE 'A' WIRE OR ITS EQUIVALENT.
 2. THREE PHASE MOTORS ARE PROTECTED UNDER PRIMARY SINGLE PHASING CONDITIONS.
 3. USE COPPER CONDUCTORS ONLY.

- INDOOR RELATIVE HUMIDITY JUMPER**
- LOW AMBIENT LOCKOUT**
- PWR CURRENT LOOP POWER**
- LOW PRESSURE SWITCH**
- LIMIT SWITCH (MANUAL-RESET)**
- LIMIT SWITCH**
- OUTDOOR AIR QUALITY**
- OUTDOOR AIR TEMP SEN**
- OVERLOAD**
- OUTDOOR FAN MOTOR**
- PLUG ASSEMBLY**
- POTENTIOMETER**
- PHASE MONITOR RELAY**
- QUADRUPLE TERMINAL RELAY**
- RETURN AIR TEMP SEN**
- REMOTE OCCUPANCY**
- SUPPLY AIR TEMP SENSOR**
- SENSOR**
- SET POINT OFFSET**
- SUPPLY FAN STATUS**
- TIME DELAY RELAY(WINTER START)**
- TRANSFORMER**
- VARIABLE FREQUENCY DRIVE**

- IRH**
- JMP**
- LA**
- LOOP**
- LPS**
- LSM**
- LS**
- OAQ**
- OAT**
- OFM**
- OL**
- PL**
- POT**
- PMR**
- QT**
- R**
- RAT**
- RMT OCC**
- SAT**
- SEN**
- SET**
- SFS**
- TDR**
- TRAN**
- VFD**

- CONTRACTOR/COMPRESSOR**
- CAPACITOR**
- CIRCUIT BREAKER**
- CRANKCASE HEATER**
- CARRIER COMFORT NETWORK**
- SAFE COMPRESSOR SAFETY**
- CONDENSATE OVERFLOW SWT**
- COMPRESSOR MOTOR**
- COMP**
- COFS**
- CTB**
- DIRECT DIGITAL CONTROL**
- ENERGY RECOVERY VENTILATOR**
- FACILITY INSTALLED OPTION**
- FIRE SHUT DOWN**
- FUSE**
- GROUND**
- HEATER CONTACTOR**
- HIGH PRESSURE SWITCH**
- INDOOR AIR QUALITY SENSORS**
- INDOOR FAN CONTACTOR**
- INDOOR FAN CIRCUIT BREAKER**
- INDOOR FAN TERMINAL BLOCK**
- INDOOR FAN MOTOR**
- CONTRACTOR/COMPRESSOR**
- CAPACITOR**
- CIRCUIT BREAKER**
- CRANKCASE HEATER**

- C**
- CAP**
- CB**
- CCH**
- CCN**
- CCMP**
- CCOFS**
- CCOMP**
- CCTB**
- CCDC**
- CCERV**
- CCFSD**
- CCFU**
- CCGND**
- CCHC**
- CCHPS**
- CCIAQ**
- CCIFC**
- CCIFCB**
- CCIFTB**
- CCIFM**
- CCIFM**
- CCCAP**
- CCCB**
- CCCH**

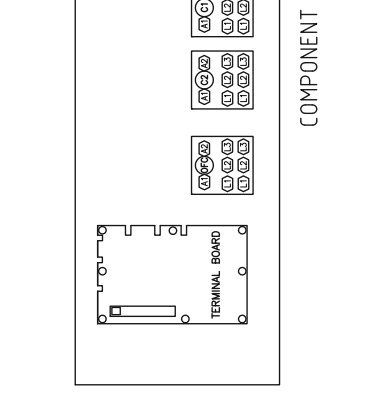

Typical Control Schematic 50TCMA Series

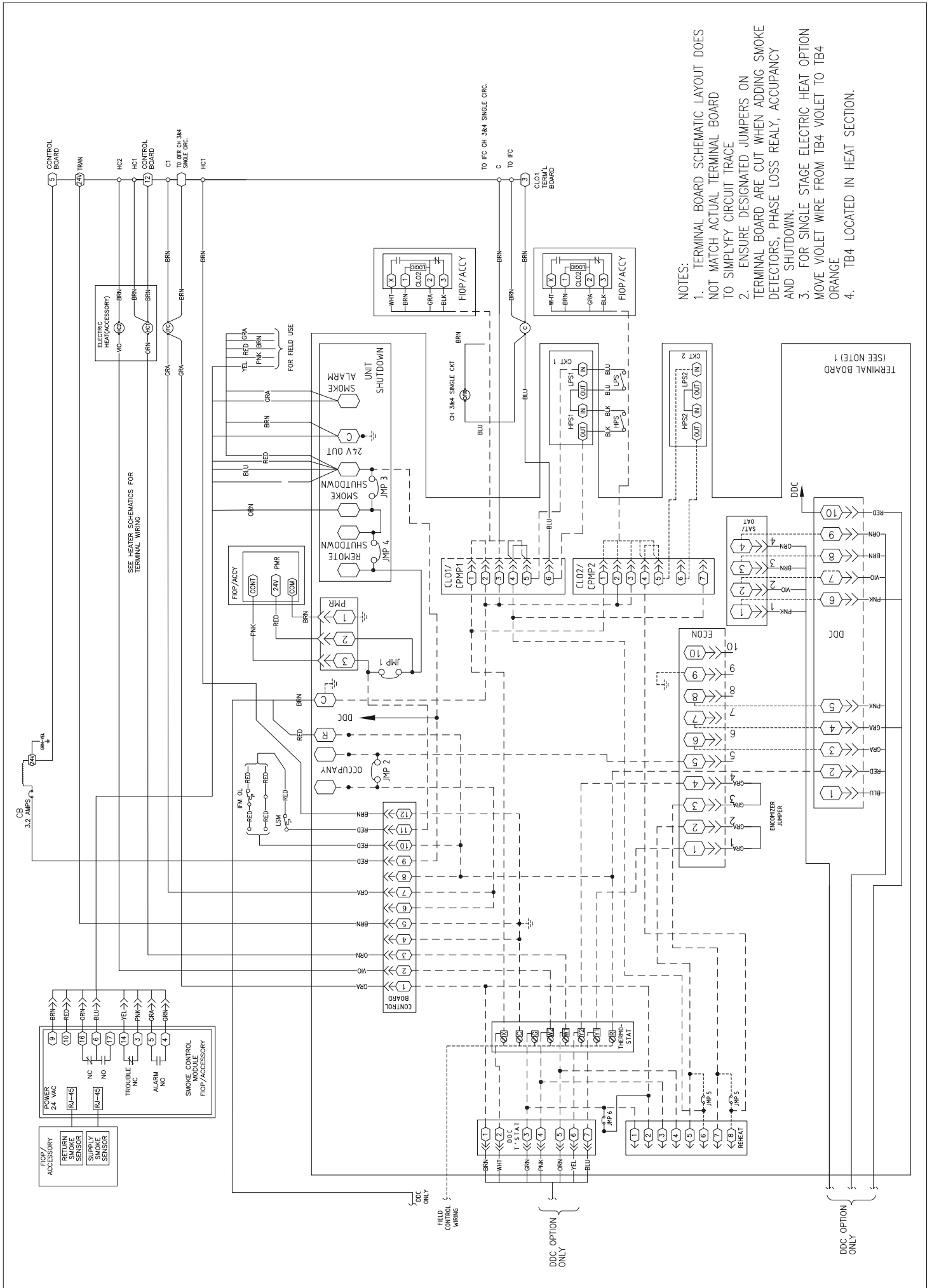

- NOTES:
1. TERMINAL BOARD SCHEMATIC LAYOUT DOES NOT MATCH ACTUAL TERMINAL BOARD TO SIMPLIFY CIRCUIT TRACE
 2. ENSURE DESIGNATED JUMPERS ON TERMINAL BOARD ARE CUT WHEN ADDING SMOKE DETECTORS, PHASE LOSS REALY, OCCUPANCY AND SHUTDOWN
 3. FOR SINGLE STAGE ELECTRIC HEAT OPTION MOVE VIOLET WIRE FROM TB4 VIOLET TO TB4 ORANGE
 4. TB4 LOCATED IN HEAT SECTION.

Typical Control Schematic 50TCMD Series

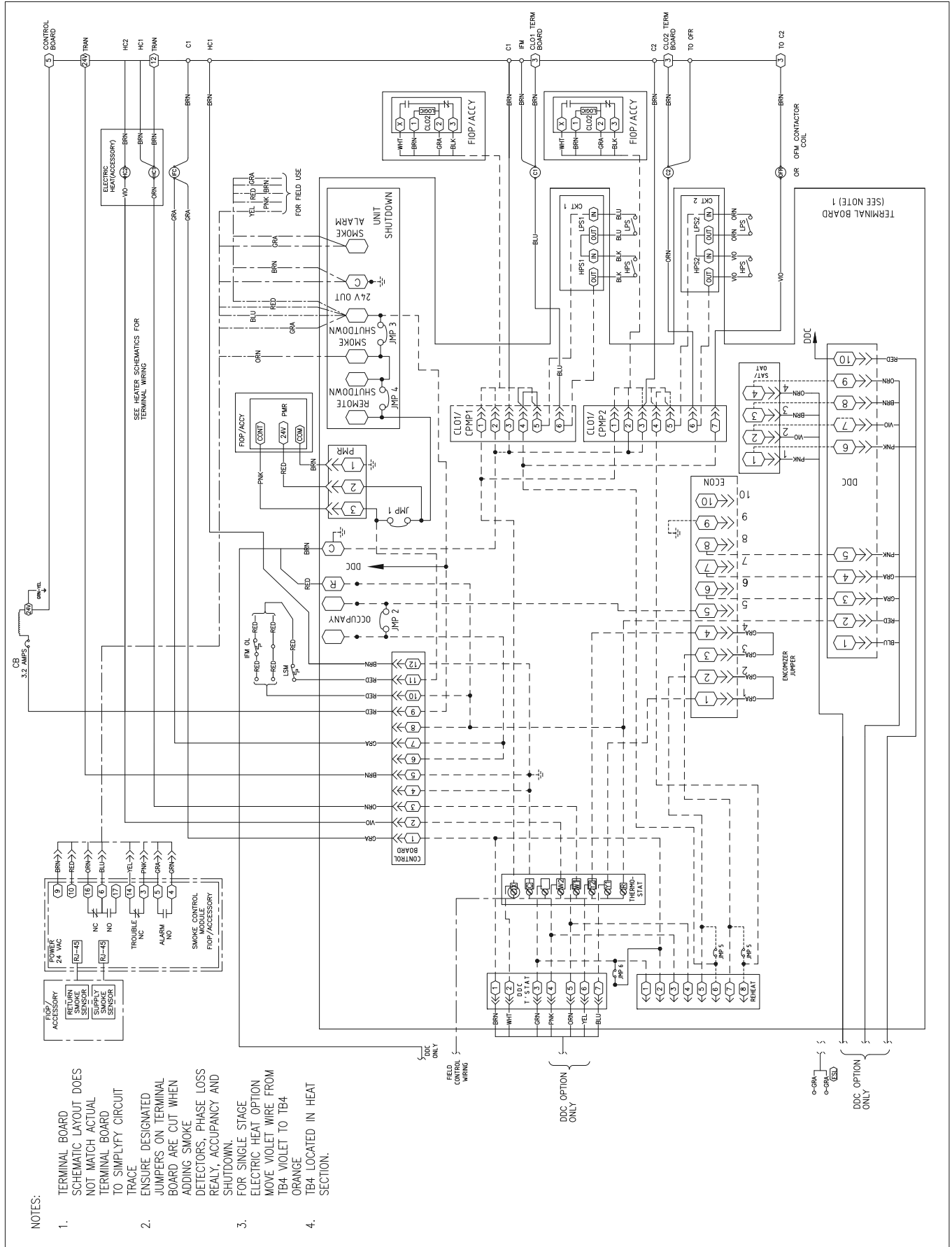

NOTES:

1. TERMINAL BOARD SCHEMATIC LAYOUT DOES NOT MATCH ACTUAL TERMINAL BOARD TO SIMPLIFY CIRCUIT TRACE
2. ENSURE DESIGNATED JUMPERS ON TERMINAL BOARD ARE CUT WHEN ADDING SMOKE DETECTORS, PHASE LOSS REALY, OCCUPANCY AND SHUTDOWN.
3. FOR SINGLE STAGE ELECTRIC HEAT OPTION MOVE VIOLET WIRE FROM TB4-VIOLET TO TB4-ORANGE
4. TB4-LOCATED IN HEAT SECTION.

APPLICATION DATA

Min operating ambient temp (cooling)

In mechanical cooling mode, your Carrier rooftop can safely operate down to an outdoor ambient temperature of 40°F (4°C) and 25°F (- 4°C), with an accessory winter start kit.

Max operating ambient temp (cooling)

The maximum operating ambient temperature for cooling mode is 125°F (52°C).

Airflow

All units are draw-through in cooling mode.

Motor limits; Brake horsepower (BHP)

Due to Carrier's internal unit design, air path, and specially designed motors, the full horsepower (maximum continuous BHP) band, can be used with the utmost confidence. There is no need for extra safety factors, as Carrier's motors are designed and rigorously tested to use the entire, listed BHP range without either nuisance tripping or premature motor failure.

Sizing a rooftop

Bigger isn't necessarily better. While an air conditioner needs to have enough capacity to meet the load, it doesn't need excess capacity. In fact, having excess capacity typically results in very poor part load performance and humidity control.

Using higher design temperatures than ASHRAE recommends for your location, adding "safety factors" to the calculated load, and rounding up to the next largest unit, are all signs of oversizing air conditioners. Oversizing can cause short-cycling, and short cycling leads to poor humidity control, reduced efficiency, higher utility bills, drastic indoor temperature swings, excessive noise, and increased wear and tear on the air conditioner.

Rather than oversizing an air conditioner, wise contractors and engineers "right-size" or even slightly undersize air conditioners. Correctly sizing an air conditioner controls humidity better; promotes efficiency; reduces utility bills; extends equipment life, and maintains even, comfortable temperatures.

Winter start

Carrier's winter start kit extends the low ambient limit of your rooftop to 25°F (- 4°C). The kit bypasses the low pressure switch, preventing nuisance tripping of the low pressure switch. Other low ambient precautions may still be prudent.

GUIDE SPECIFICATIONS - 50TCM

Cooling Only/Electric Heat Packaged Rooftop HVAC Guide Specifications Size Range: 6 to 12.5 Nominal Tons



System Description

Small-Capacity Self-Contained Air Conditioners (50TCM)

Outdoor, rooftop mounted, electrically controlled, heating and cooling unit utilizing hermetic scroll compressor(s) for cooling duty and electric for heating duty.

Quality Assurance

1. Unit shall achieve ASHRAE 90.1 minimum efficiency requirements (2010 version).
2. Unit shall be designed to conform to ASHRAE 15, 2001.
3. Unit shall be rated in accordance with AHRI Standards 210/240 and 340/360.
4. Insulation and adhesive shall meet NFPA 90A requirements for flame spread and smoke generation.
5. Unit casing shall be capable of withstanding 500-hour salt spray exposure per ASTM B117 (scribed specimen).
6. Unit shall be designed in accordance with ISO 9001:2000, and shall be manufactured in a registered ISO 9001:2000 facility.
7. Unit shall be subjected to a completely automated run test on the assembly line. The data for each unit will be stored at the factory, and must be available upon request.
8. Unit shall be designed in accordance with UL Standard 1995, including tested to withstand rain.

Delivery, Storage, and Handling

1. Unit shall be stored and handled per manufacturer's recommendations.
2. Lifted by crane requires either shipping top panel or spreader bars.
3. Unit shall only be stored or positioned in the upright position.

Product General

1. Factory assembled, single-piece heating and cooling rooftop unit. Contained within the unit enclosure shall be all factory wiring, piping, controls, and special features required prior to field start-up.
2. Unit shall use environmentally safe, Puron refrigerant.
3. Unit shall be installed in accordance with the manufacturer's instructions.
4. Unit must be selected and installed in compliance with local, state, and federal codes.
5. Interior cabinet surfaces shall be insulated with closed cell foam minimum ½ -in. thick, minimum density 3.1lb/ft³.

Unit Cabinet

1. Unit cabinet shall be constructed of galvanized steel, and shall be bonderized and coated with a pre-painted baked enamel finish on all externally exposed surfaces.
2. Unit cabinet exterior paint shall be: film thickness, (dry) 76mm minimum, gloss (per ASTM D523, 60°F): 60, Hardness: H-2H Pencil hardness.
3. Evaporator fan compartment interior cabinet insulation shall conform to AHRI Standards 210/240 or 340/360 minimum exterior sweat criteria.
4. Base of unit shall have a minimum of four locations for thru-the-base gas and electrical connections (factory installed or field installed), standard.
5. Base Rail
 - a) Unit shall have base rails on a minimum of 2 sides.
 - b) Holes shall be provided in the base rails for rigging shackles to ease maneuvering and overhead rigging.
 - c) Holes shall be provided in the base rail for moving the rooftop by fork truck.
 - d) Base rail shall be a minimum of 16 gauge thickness.
6. Condensate pan and connections:
 - a) Shall be a sloped condensate drain pan made of a non-corrosive material.
 - b) Shall comply with ASHRAE Standard 62.
 - c) Shall use a 3/4" - 14 NPT drain connection, possible either through the bottom or end of the drain pan.
Connection shall be made per manufacturer's recommendations.
7. Top panel:
Shall be a single piece top panel on 07 size, two piece on 08 thru 14 size.
8. Electrical Connections:
All unit power wiring shall enter unit cabinet at a single, factory-prepared, knock out location.

9. Component access panels (standard):
 - a) Cabinet panels shall be easily removable for servicing.
 - b) Unit shall have one factory installed; tool-less, removable, filter access panel.
 - c) Panels covering control box, indoor fan, indoor fan motor, and compressors shall have molded composite handles.
 - d) Handles shall be UV modified, composite, permanently attached, and recessed into the panel.
 - e) Screws on the vertical portion of all removable access panels shall engage into heat resistant, molded composite collars.
 - f) Collars shall be removable and easily replaceable using manufacturer recommended parts.

Coils

Standard Aluminum fin-Copper Tube Coils:

1. Standard evaporator and condenser coils shall have aluminum lanced plate fins mechanically bonded to seam- less internally grooved copper tubes with all joints brazed.
2. Evaporator coils shall be leak tested to 150 psig, pressure tested to 450 psig, and qualified to UL 1995 burst test at 1775 psig.
3. Condenser coils shall be leak tested to 150 psig, pressure tested to 450 psig, and qualified to UL 1995 burst test at 1980 psig.

Optional Pre-coated aluminum-fin condenser coils:

1. Shall have a durable epoxy-phenolic coating to provide protection in mildly corrosive coastal environments.
2. Coating shall be applied to the aluminum fin stock prior to the fin stamping process to create an inert barrier between the aluminum fin and copper tube.
3. Epoxy-phenolic barrier shall minimize galvanic action between dissimilar metals.

Optional Copper-fin evaporator and condenser coils:

Shall be constructed of copper fins mechanically bonded to copper tubes

Refrigerant Components

1. Refrigerant circuit shall include the following control, safety, and maintenance features:
 - a) Fixed orifice metering system shall prevent mal-distribution of two-phase refrigerant by including multiple fixed orifice devices in each refrigeration circuit. Each orifice is to be optimized to the coil circuit it serves.
 - b) Refrigerant filter drier.
 - c) Service gauge connections on suction and discharge lines.
2. There shall be gauge line access, covered cap:
 - a) The plug shall be easy to remove and replace.
 - b) When the plug is removed, the gauge access port shall enable maintenance personnel to route their pressure gauge lines.
 - c) This gauge access port shall facilitate correct and accurate condenser pressure readings by enabling the reading with the compressor access panel on.
 - d) The plug shall be made of a leak proof, UV-resistant, composite material.
3. Compressors:
 - a) Unit shall use one fully hermetic, scroll compressor for each independent refrigeration circuit.
 - b) Compressor motors shall be cooled by refrigerant gas passing through motor windings.
 - c) Compressors shall be internally protected from high discharge temperature conditions.
 - d) Compressors shall be protected from an over-temperature and over-ampereage conditions by an internal, motor overload device.
 - e) Compressor shall be factory mounted on rubber grommets.
 - f) Compressor motors shall have internal line break thermal, current overload and high pressure differential protection.
 - g) Crankcase heaters shall not be required for normal operating range, unless provided by compressor manufacturer due to refrigerant charge limits.

Evaporator Fan and Motor

Evaporator Fan Motor:

1. Shall have permanently lubricated bearings.
2. Shall have inherent automatic-reset thermal overload protection.
3. Shall have a maximum continuous bhp rating for continuous duty operation; no safety factors above that rating shall be required.

Belt-driven Evaporator Fan:

1. Belt drive shall include an adjustable pitch motor pulley.
2. Shall use sealed, permanently lubricated ball-bearing type.
3. Blower fan shall be double-inlet type with forward-curved blades.
4. Shall be constructed from steel with a corrosion resistant finish and dynamically balanced.

Condenser Fans and Motors

Condenser Fan Motors:

1. Shall be a totally enclosed motor.
2. Shall use permanently lubricated bearings.
3. Shall have inherent thermal overload protection with an automatic reset feature.
4. Shall use a shaft-down design on 07 to 09 models and shaft-up design on 12, 14 sizes with rain shield.

Condenser Fans:

1. Shall be a direct-driven propeller type fan.
2. Shall have aluminum blades riveted to corrosion-resistant steel spiders and shall be dynamically balanced.

Electric and Electronic Control System for HVAC

General:

1. Shall be complete with self-contained low-voltage control circuit protected by a resettable circuit breaker on the 24V transformer side. Transformer shall have 75VA capability.
2. Shall utilize color-coded wiring.
3. Shall include a central control terminal board to conveniently and safely provide connection points for vital control functions such as: smoke detectors, phase monitor, thermostat, DDC control options, and low and high pressure switches.
4. Unit shall include a minimum of one 8-pin screw terminal connection board for connection of control wiring.

Safeties:

1. Compressor over-temperature, over current.
2. Low pressure switch:
 - a. Units with 2 compressors shall have different sized connectors for the circuit 1 and circuit 2 low and high pressure switches. They shall physically prevent the cross wiring of the safety switches between circuits 1 and 2.
 - b. Low pressure switch shall use different color wire than the high pressure switch. The purpose is to assist the installer and service technician to correctly wire and or troubleshoot the rooftop unit.
3. High pressure switch:
 - a. Units with 2 compressors shall have different sized connectors for the circuit 1 and circuit 2 low and high pressure switches. They shall physically prevent the cross wiring of the safety switches between circuits 1 and 2.
 - b. High pressure switch shall use different color wire than the low pressure switch. The purpose is to assist the installer and service technician to correctly wire and or troubleshoot the rooftop unit.
4. Automatic reset, motor thermal overload protector.

Filter Section

1. Filters access is specified in the unit cabinet section of this specification.
2. Filters shall be held in place by a pivoting filter tray, facilitating easy removal and installation.
3. Shall consist of factory-installed, low velocity, throw-away 2 -in. thick fiberglass filters.
4. Filters shall be standard, commercially available sizes.
5. Only one size filter per unit is allowed.

Operating Characteristics

1. Unit shall be capable of starting and running at 125°F (52°C) ambient outdoor temperature, meeting maximum load criteria of AHRI Standard 210/240 or 340/360 at ± 10% voltage.
2. Compressor with standard controls shall be capable of operation down to 40°F (4°C), ambient outdoor temperatures. Accessory winter start kit is necessary if mechanically cooling at ambient temperatures down to 25°F (- 4°C).
3. Unit shall discharge supply air horizontally as shown on contract drawings.
4. Unit shall be factory configured for horizontal supply and return configurations.

Thermostats

Thermostat must:

1. Energize both "W" and "G" when calling for heat.
2. Have capability to energize 2 different stages of cooling, and 2 different stages of heating.
3. Include capability for occupancy scheduling.

Electrical Requirements

Main power supply voltage, phase, and frequency must match those required by the manufacturer.

Special Features: Options and Accessories

Open protocol, direct digital controller:

1. Shall be ASHRAE 62-2001 compliant.
2. Shall accept 18-30VAC, 50-60Hz, and consumer 15VA or less power.
3. Shall have an operating temperature range from - 40°F (- 40°C) to 130°F (54°C), 10% - 90% RH (non-condensing).
4. Shall include built-in protocol for BACNET (MS/TP and PTP modes), Modbus (RTU and ASCII), Johnson N2 and LonWorks. LonWorks Echelon processor required for all Lon applications shall be contained in separate communication board.
5. Shall allow access of up to 62 network variables (SNVT). Shall be compatible with all open controllers
6. Baud rate Controller shall be selectable using a dipswitch.
7. Shall have an LED display independently showing the status of serial communication, running, errors, power, all digital outputs, and all analog inputs.
8. Shall accept the following inputs: space temperature, set point adjustment, outdoor air temperature, indoor air quality, outdoor air quality, compressor lock-out, fire shutdown, enthalpy switch, and fan status/filter status/ humidity/ remote occupancy.
9. Shall provide the following outputs: Fan, cooling stage 1, cooling stage 2, heat stage 1, heat stage 2, heat stage 3/ exhaust.
10. Shall have built-in surge protection circuitry through solid state polyswitches. Polyswitches shall be used on in-coming power and network connections. Polyswitches will return to normal when the "trip" condition clears.
11. Shall have a battery backup capable of a minimum of 10,000 hours of data and time clock retention during power outages.
12. Shall have built- in support for Carrier technician tool.
13. Shall include an EIA-485 protocol communication port, an access port for connection of either a computer or a Carrier technician tool, an EIA-485 port for network communication to intelligent space sensors and displays, and a port to connect an optional LonWorks communications card.
14. Software upgrades will be accomplished by either local or remote download. No software upgrades through chip replacements are allowed.

PremierLink controller:

1. Shall be ASHRAE 62-2001 compliant.
2. Shall accept 18-32VAC input power.
3. Shall have an operating temperature range from - 40°F (- 40°C) to 158°F (70°C), 10% - 95% RH (non-condensing).
4. Controller shall accept the following inputs: space temperature, set point adjustment, outdoor air temperature, indoor air quality, outdoor air quality, indoor relative humidity, compressor lock-out, fire shutdown, enthalpy, fan status, remote time clock/door switch.
5. Shall accept a CO2 sensor in the conditioned space, and be Demand Control Ventilation (DCV) ready.
6. Shall provide the following outputs: Fan, cooling stage 1, cooling stage 2, heat stage 1, heat stage 2, heat stage 3/ exhaust/ occupied.
7. Unit shall provide surge protection for the controller through a field installed circuit breaker.
8. Shall be Internet capable, and communicate at a Baud rate of 38.4K or faster
9. Shall have an LED display independently showing the status of activity on the communication bus, and processor operation.
10. Shall include an EIA-485 protocol communication port, an access port for connection of either a computer or a Carrier technician tool, an EIA-485 port for network communication to intelligent space sensors and displays, and a port to connect an optional LonWorks plug-in communications card.
11. Shall have built-in Carrier Comfort Network (CCN) protocol, and be compatible with other CCN devices, including ComfortLink and ComfortVIEW controllers.
12. Shall have built-in support for Carrier technician tool.
13. Software upgrades will be accomplished by local download. Software upgrades through chip replacements are not allowed.
14. Shall be shock resistant in all planes to 5G peak, 11ms during operation, and 100G peak, 11ms during storage.
15. Shall be vibration resistant in all planes to 1.5G @ 20-300 Hz.
16. Shall support a bus length of 4000 ft max, 60 devices per 1000 ft section, and 1 RS-485 repeater per 1000ft sections.

Manual damper:

Manual damper package shall consist of damper, air inlet screen, and rain hood which can be preset to admit up to 50% outdoor air for year round ventilation.

Head Pressure Control Package:

1. Controller shall control coil head pressure by condenser-fan speed modulation or condenser-fan cycling and wind baffles.
2. Shall consist of solid-state control and condenser-coil temperature sensor to maintain condensing temperature between 90°F (32°C) and 110°F (43°C) at outdoor ambient temperatures down to -20°F (-29°C).

High/Medium-Static Indoor Fan Motor(s) and Drive(s):

Shall be factory-installed to provide additional performance range.

Smoke detectors:

1. Shall be a Four-Wire Controller and Detector.
2. Shall be environmental compensated with differential sensing for reliable, stable, and drift-free sensitivity.
3. Shall use magnet-activated test/reset sensor switches.
4. Shall have tool-less connection terminal access.
5. Shall have a recessed momentary switch for testing and resetting the detector.
6. Controller shall include:
 - a) One set of normally open alarm initiation contacts for connection to an initiating device circuit on a fire alarm control panel.
 - b) Two Form-C auxiliary alarm relays for interface with rooftop unit or other equipment.
 - c) One Form-C supervision (trouble) relay to control the operation of the Trouble LED on a remote test/reset station.
 - d) Capable of direct connection to two individual detector modules.
 - e) Can be wired to up to 14 other duct smoke detectors for multiple fan shutdown applications.

Winter start kit:

1. Shall contain a bypass device around the low pressure switch.
2. Shall be required when mechanical cooling is required down to 25°F (-4°C).

Time Guard:

1. Shall prevent compressor short-cycling by providing a 5-minute delay (± 2 minutes) before restarting a compressor after shutdown for any reason.
2. One device shall be required per compressor.

Electric Heat:

1. Heater element open coil resistance wire, nickel-chrome alloy, 0.29 inches inside diameter, strung through ceramic insulators mounted on metal frame. Coil ends are staked and welded to terminal screw slots.
2. Heater assemblies are provided with integral fusing for protection of internal heater circuits. Auto reset thermo limit controls, magnetic heater contactors (24V coil) and terminal block all mounted in electric heater control box (minimum 18 ga galvanized steel) attached to end of heater assembly.

Notes

Notes

