



Neoclima



Service Manual

Air Cooled Modular Chiller – NCX-H



Content

Part 1 Product Introduction	3
1.1 Feature	3
1.2 Nomenclature	4
1.3 Function Introduction	5
Part 2 Product Parameter	6
2.1 Appearance	6
2.2 Specification.	7
2.3 Product Capacity Correction	8
2.4.Physical Dimension	10
2.5 Electrical wiring.	12
2.6. Unit system principle diagram	15
2.7. Explode View	16
Part 3 Installation and Commissioning.	25
3.1 Preparation before Installation	25
3.2 Installation of the Chiller	26
3.3 Installation of the Water System.	29
3.4 Electrical wiring.	30
3.5. Trial operation.	32
3.6 Commissioning	35
3.7 Project Acceptance.	37
3.8. Grades and standards for refrigeration compressor oil-filled volume	37
3.9 Operation and Maintenance	38
Part 4 After-sales	46
4.1 Main Spare Parts of the Chiller	46
4.2 Main Spare Parts of the Electric System.	48
4.3 Function and Control of the Chiller.	49
Part 5 Troubleshooting	57
5.1 Unit fault code table	57
5.2 Fault recovery Measures	59
5.3 Failure Analysis	61

Part 1 Product Introduction

1.1 Feature

This X-Structure Modular Chiller uses air as the cold/heat source, and it is an air cooled modular chiller (heat pump) which uses air-cooled and water-evaporate mixing condensation method. The chiller is used as a cooling and heating intergrated facility which leaves out many auxiliary equipment like cooling tower and relative pipe system. It has simple structure, small installation space requirement and less energy consumption, and the maintenance and management is very convenient. The chiller is suitable for those HVAC projects which need the air conditioners power-on full year around but without heating network or other reliable heat source. It is one of the preferred programs. The central air conditioner system comprised by chiller and terminal equipment like fan coil, air handling unit is flexible and with variable control methods.

Applicable places

The X-Structure Modular Chiller can be used in middle-sized commercial places such as factory, station, hotel, villa, office building, etc.

Products Characteristics

1. EER :A class

The chiller belongs to Neoclima pioneering X-Structure design, optimized and improved basing on air-side heat exchanger and water-side heat exchanger, which can reach 1st Level EER and fully meets the national direction of saving energy.

2. Brand new X structure

Innovative brand-new X structure design, which makes single chiller good ventilation, and form wind tunnel effect between multi modular chillers. And this design can increase flow volume, improve the incoming wind uniformity and enhance the wind-side heat exchange ability.

3. Seamless connect

- It uses flexible pipe, ie seamless connect, to connect the chiller, which occupies less space
- The X structure makes the space larger after assembly, which makes it easier to maintenance and repair

4. Falling film condensing technology

The wind-side fin heat exchanger use brand new falling film condensing technology, which largely reduce the condensing temperature, improve the chiller EER and extend the compressor lifetime.

5. Long lifetime fin heat exchanger

The chiller uses epoxy coating anticorrosion golden hydrophilic aluminum foil, whose antiseptis performance is 10 times than the normal one

6. Shell and Tube heat exchanger

The chiller uses high-efficient shell and tube heat exchanger, and the advantage is: low water quality requirement, high reliability, long lifetime, easy maintenance.

7. Accurate temperate control technology

The chiller uses Paralleled dual compressors Technology in single module, multi modular chiller can realize to adjust the water temperature within $\pm 0.5^{\circ}\text{C}$

8. Flexible design -- Main module can be anyone

Any single module in a chiller system can be set as the main module, which can communicate with the other modules and work according the requirements. And different type modular chiller can be combined

at will by the users.

9. People-oriented user interface, self-diagnose and long distance control

The people-oriented user interface is easier and safer to operate; the self-diagnose function will automatic protect the system and alarm, which makes system failure inquiry and troubleshooting faster; and the long distance control function can work together with the BMS by the RS485 communication protocol physical terminal.

10. Wide Cooling & Heating operation

No matter when it is as high as 52°C hot summer or -12°C in the cold winter, the unit could operate perfectly.

11. High reliability

The core cooling parts of the chiller, compressor, heat exchanger, throttling device and cooling valve, all use International and national famous products, along with NEOCLIMA complete technological process, strict QC and monitoring to ensure the high performance and reliability of the chiller.

1.2 Nomenclature

NCX - H 30

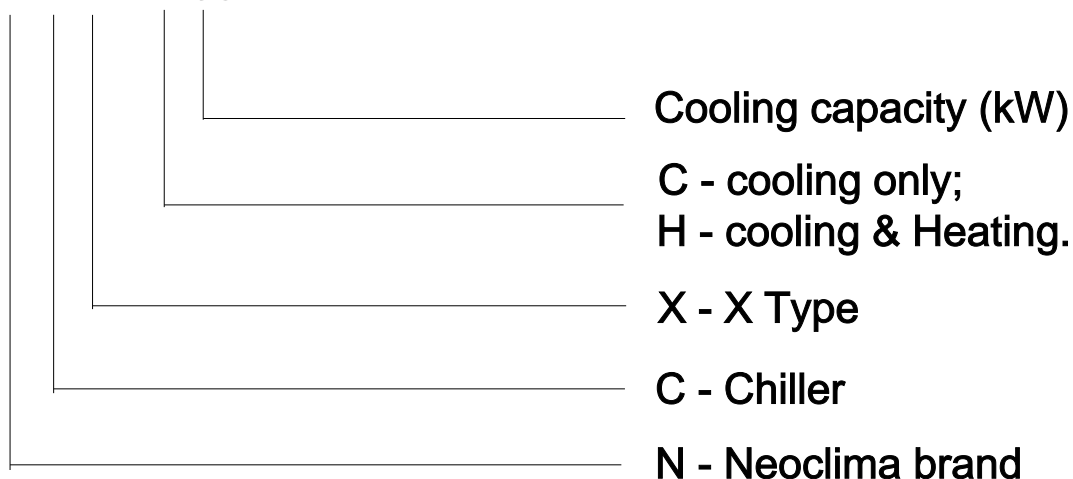

1.3 Function Introduction

The control system of the Air Cooled Modular Chiller (Heat Pump) is comprised of a main module controller and many sub-module controllers, and they connect with each other by networking. The chiller realize intelligent control and management under the control of main module controller. The specification is listed in the following chart.



Classification	Name	NCX-H30	NCX-H65
Protection function	high pressure protection	○	○
	low pressure protection	○	○
	over-load protection (cooling mode)	○	○
	Phase-sequence protection (lack/reverse phase)	○	○
	anti-freezing protection (cooling mode)	○	○
	Freezing point switch protection	-	-
	over-current protection of compressor	○	○
	Four-way valve reverse protection	○	○
	over heat protection (heating mode)	○	○
	Anti-freezing protection (in winter)	○	○
	water flow protection	○	○
	Flow switch protection	○	○
	Compressor delay protection	○	○
	sensor failure alarm	○	○
	failure code display function	○	○
Control function	Operation mode display	○	○
	Clock, time switch display	○	○
	Compressor operating display	○	○
	Set temperature display	○	○
	Water-return/water outlet temperature display	○	○
	Electrical heating operating display	○	○
	Expansion valve opening degree display	○	○
Operation mode	Cooling mode	○	○
	Heating mode	○	○
	Heat Recovery	—	—

note :○positive

— negative

Part 2 Product Parameter

2.1 Appearance

Product Type	Outline Drawing
<p>NCX-H30</p>	
<p>NCX-H65</p>	
<p>Wired Controller</p>	 <p>Suitable for all the above products</p>

2.2 Specification

Model name			NCX-H30	NCX-H65
Capacity	Cooling	Btu/h	100000	222000
		kW	30	65
	Heating	Btu/h	110000	245500
		kW	33	72
Electric Data	Power Supply	V~,Hz,Ph	380~415,50,3	380~415,50,3
	Cooling Power Input	kW	8.8	19.1
	Heating Power Input	kW	10.2	21.0
	Cooling Current	A	15.7	34.2
	Heating Current	A	18.2	37.6
Compressor	Type		Hermetic scroll	
	Quantity	Pieces	1	2
Refrigerant Type			R410a	
Air Side Heat Exchanger	Type		High-efficient fin heat exchanger	
	Fan Quantity	Pieces	1	2
	Air Flow Volume	m ³ /h	13500	13500x2
Water Side Heat Exchanger	Type		High-efficiency tube and tube heat exchanger	High-efficiency shell and tube heat exchanger
	Water Resistance	kPa	45	25
	Water Flow Volume	m ³ /h	5.2	11.2
	Max. Pressure	MPa	1	1
Dimension(WxDxH)	Net	mm	1580x1020x2060	2090x1020x2050
	Packing	mm	1680x1120x2160	2190x1120x2150
Weight	Net	kg	350	530
	Gross	kg	420	580
Inlet/Outlet Water Pipe		mm	DN40	DN50
Noise		dB(A)	≤65	≤70
Safety Protection			High/low pressure protection, lack/reverse phase protection, water lack protection, water flow protection, anti-freezing protection, etc.	

Note:

All the above performance parameter belongs to single module, you can combine them into a system with different performance as you need. The cooling capacity arranges from 30kW to 1040kW;

All the above data is measured base on the following working condition:

1. Rated cooling working condition: water flow 0.172 m³/(h•kW), chilled water inlet/outlet temperature 12°C/7°C, ambient temperature 35°C;
2. Rated heating working condition: water flow 0.172 m³/(h•kW), hot water inlet/outlet temperature 40°C /45°C, ambient temperature 7°C, WB temperature 6°C;
3. Keep 1m away from the chiller front and 1.5m high when detecting noise level, environmental noise is lower than 30db(A);

As a part of continuous product improvement, we reserve the right to change specifications without notice.

2.3 Product Capacity Correction

Operation Range

Product Type		NCX-H30	NCX-H65
Power supply		380V,3N~ /50Hz	
Voltage range		380V±10%	
Ambient temperature range	Cooling mode	15°C~52°C	
	Heating mode	-12°C~30°C	

Cooling capacity and power under different ambient and water outlet temperature

NCX-H30 cooling capacity and power in cooling mode

Chilled water outlet temperature (°C)	Ambient Temperature(°C)									
	25		30		35		40		46	
	Cooling capacity kW	Power consumption kW	Cooling capacity kW	Power consumption kW	Cooling capacity kW	Power consumption kW	Cooling capacity kW	Power consumption kW	Cooling capacity kW	Power consumption kW
5.00	31.03	7.18	29.19	7.75	27.87	8.41	26.18	9.14	25.16	10.05
7.00	32.25	7.22	30.83	7.86	30.00	8.80	27.61	9.29	26.27	10.12
10.00	34.27	7.31	32.73	7.93	30.81	9.00	29.20	9.40	27.45	10.21
13.00	35.47	7.40	33.60	8.06	31.99	9.27	30.53	9.51	28.83	10.32

NCX-H65 cooling capacity and power in cooling mode

Chilled water outlet temperature (°C)	Ambient Temperature(°C)									
	25		30		35		40		46	
	Cooling capacity kW	Power consumption kW	Cooling capacity kW	Power consumption kW	Cooling capacity kW	Power consumption kW	Cooling capacity kW	Power consumption kW	Cooling capacity kW	Power consumption kW
5	67.23	15.58	63.24	16.82	60.38	18.25	56.72	19.84	54.51	21.81
7	69.87	15.66	66.81	17.07	65.00	19.10	59.83	20.17	56.91	21.97
10	74.25	15.87	70.91	17.21	66.75	19.54	63.27	20.41	59.47	22.17
13	76.85	16.06	72.79	17.49	69.31	20.13	66.14	20.64	62.46	22.39

Notes: As a part of continuous product improvement, NEOCLIMA reserves the right to change specifications and design without prior notice. The specification subjects to the nameplate of the chiller

Heating capacity and power under different ambient and water outlet temperature

NCX-H30 heating capacity and power in heating mode (RH is 90%)

Hot water outlet temperature (°C)	Outdoor DB temperature(°C)									
	-10		-5		0		7		12	
	Heating capacity kW	Power consumption kW	Heating capacity kW	Power consumption kW	Heating capacity kW	Power consumption kW	Heating capacity kW	Power consumption kW	Heating capacity kW	Power consumption kW
35	18.65	8.20	22.96	8.39	28.38	8.45	34.61	8.68	40.80	8.93
40	18.13	8.81	22.37	8.99	27.55	9.17	33.87	9.45	39.61	9.56
45	---	---	21.58	9.83	26.66	9.96	33.00	10.2	38.42	10.4
50	---	---	20.89	10.72	25.84	10.86	31.58	11.14	37.36	11.32

NCX-H65 heating capacity and power in heating mode (RH is 90%)

Hot water outlet temperature (°C)	Outdoor DB temperature(°C)									
	-10		-5		0		7		12	
	Heating capacity kW	Power consumption kW	Heating capacity kW	Power consumption kW	Heating capacity kW	Power consumption kW	Heating capacity kW	Power consumption kW	Heating capacity kW	Power consumption kW
35	39.57	16.28	48.71	16.66	60.21	16.77	73.42	17.23	86.55	17.72
40	38.45	17.49	47.45	17.84	58.43	18.20	71.84	18.77	84.02	18.98
45	---	---	45.77	19.52	56.55	19.78	70.00	20.25	81.49	20.67
50	---	---	44.31	21.29	54.82	21.57	66.99	22.11	79.24	22.47

Notes:

As a part of continuous product improvement, NEOCLIMA reserves the right to change specifications and design without prior notice. The specification subjects to the nameplate of the chiller

2.4 Physical Dimension

NCX-H30

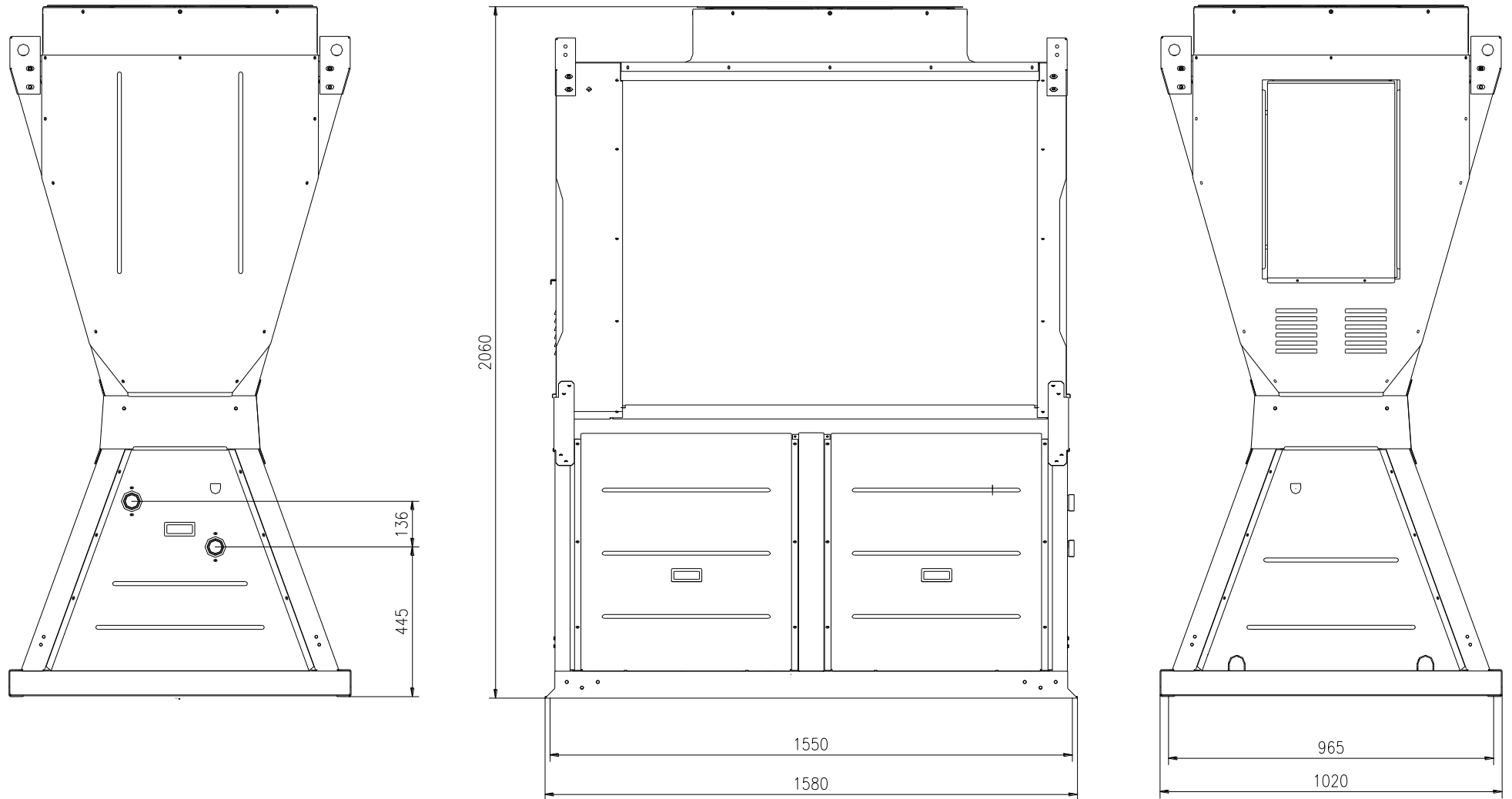

NCX-H65

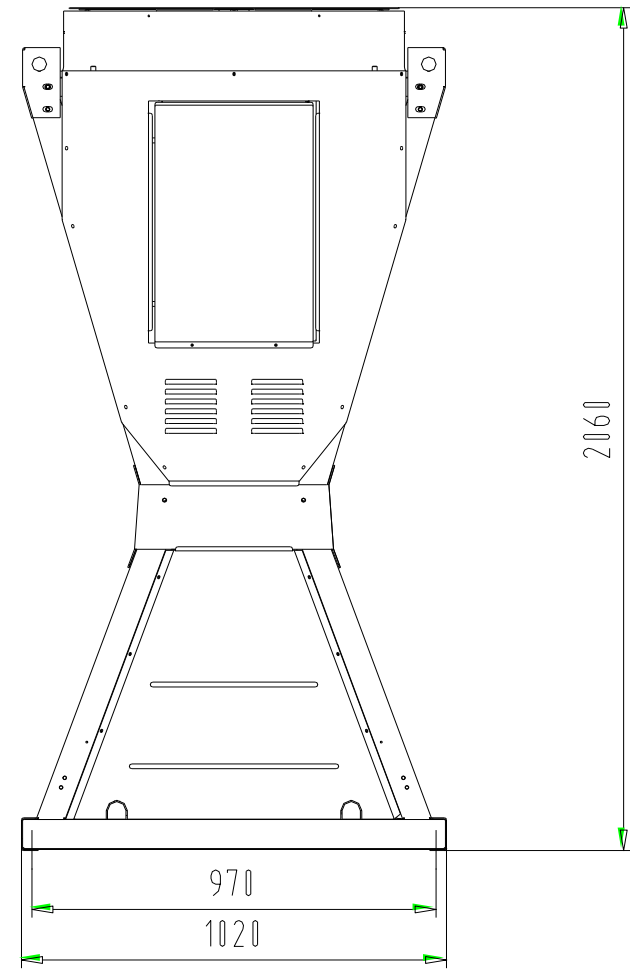
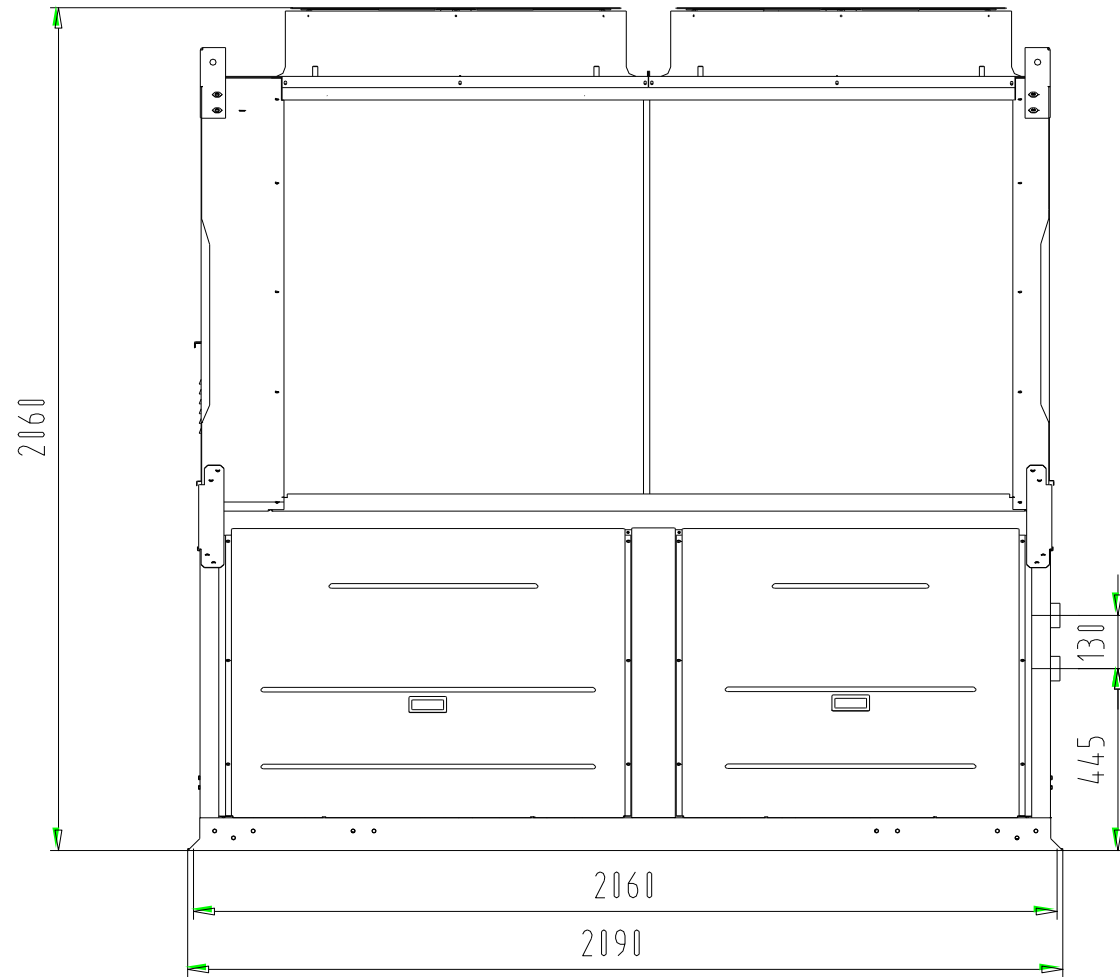

2.5 Electrical wiring

NCX-H30

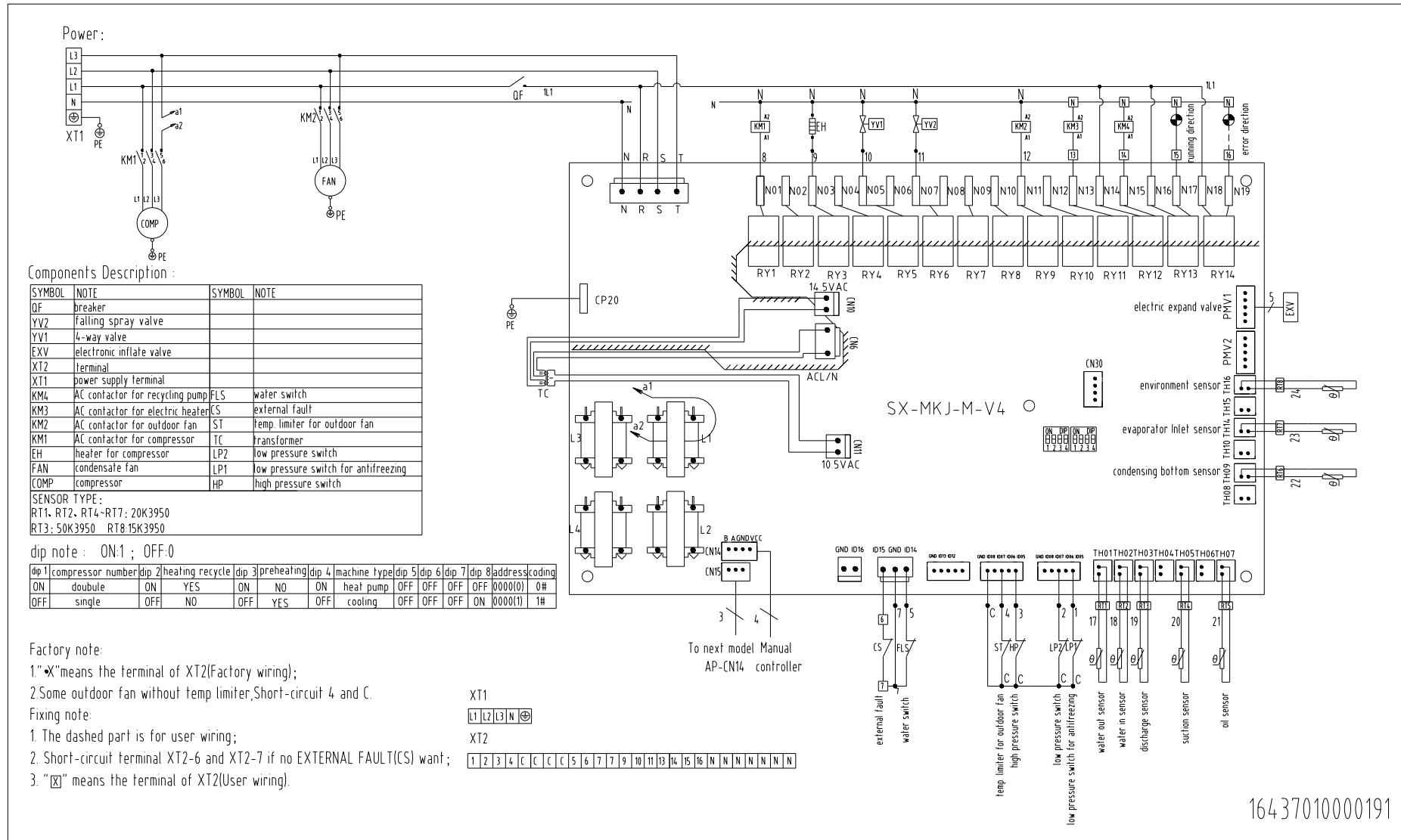

NCX-H65

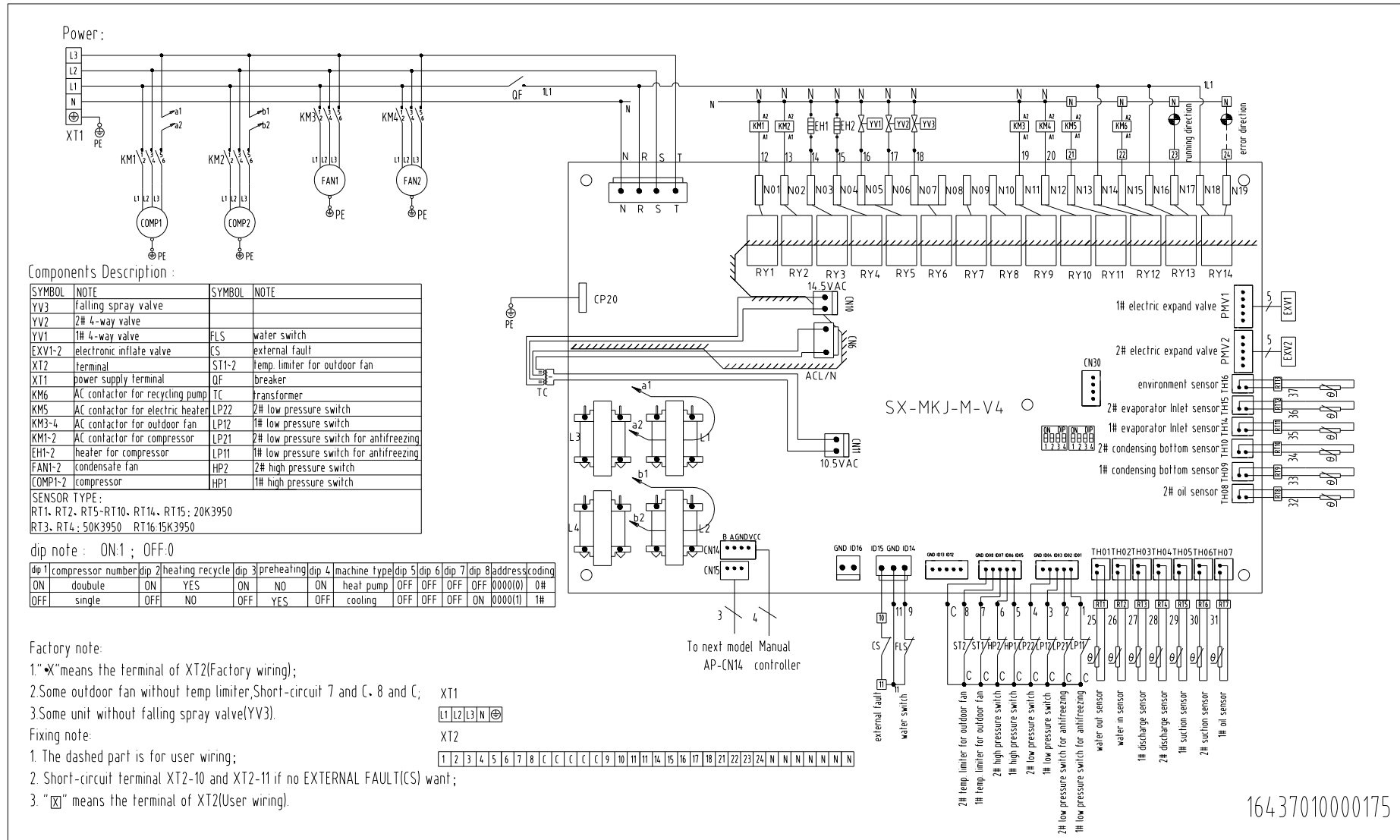

The wiring diagram of connection between the chiller and users is as follow:

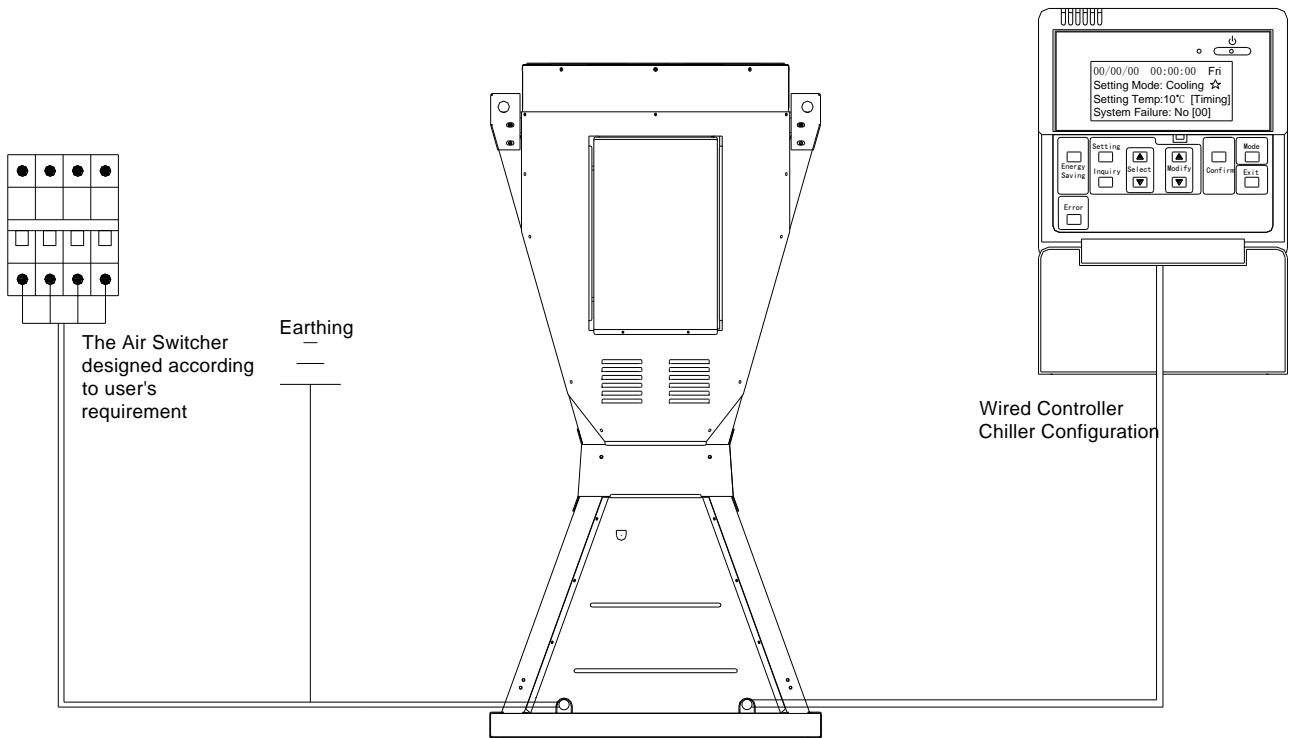

Wiring between user and the binding post in the chiller

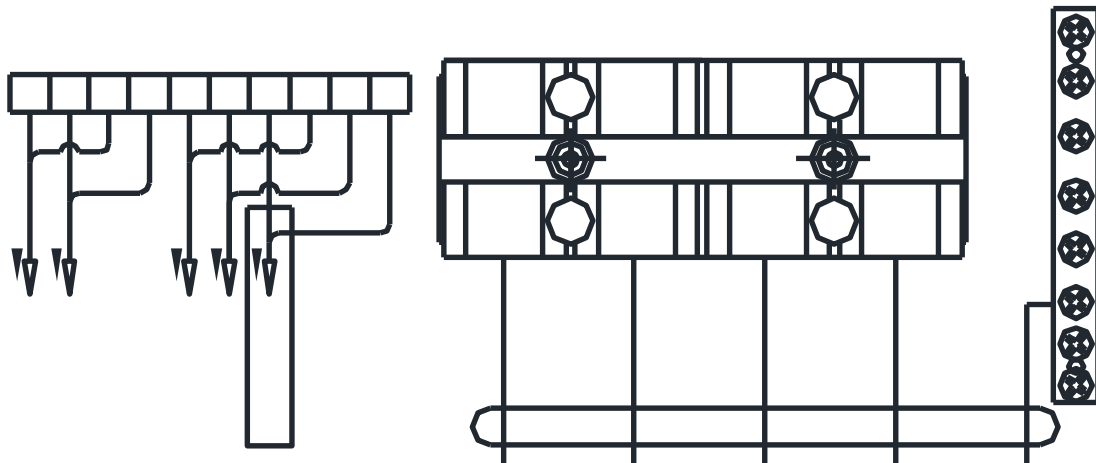

Notes: no heat recovery function. dotted line needs not to connect

Power: 380V 3N ~ 50Hz

2.6. Unit system principle diagram

Refrigeration Cycle:

Compressor inhale the low temperature and low pressure refrigerants steam which is in the evaporator, the steam inhalation after high temperature and high pressure of compressed gas discharge through the four-way valve entering finned condenser, In the condenser, high temperature and high pressure refrigerants steam change heat with outdoor air, condensation on the air after high temperature and high pressure of refrigerant liquid as electronic expansion valves throttling cooling step-down after liquid reservoirs into a shell and tube evaporator, enter the evaporator gas-liquid two phase refrigerant in the evaporator, thus completely evaporation cooling water cooling, The steam from evaporator through four-way valve and the vapor-liquid separator is compressor suction compression, again so, is a continuous loop camps in the frozen water cooling water under the effect of the air terminal equipment for entering.

Heating Cycle:

It is the reverse cycle of refrigeration, this time four-way valve change direction, as well as the refrigerant flow, namely the steam discharge from the compressor into a shell and tube condensing heat exchanger, condensing after the electronic expansion valves throttling refrigerant, after evaporation of finned heat exchanger, evaporation by compressor suction compression, and so on, is a continuous loop heat pump water in under the action of continuous air terminal equipment into.

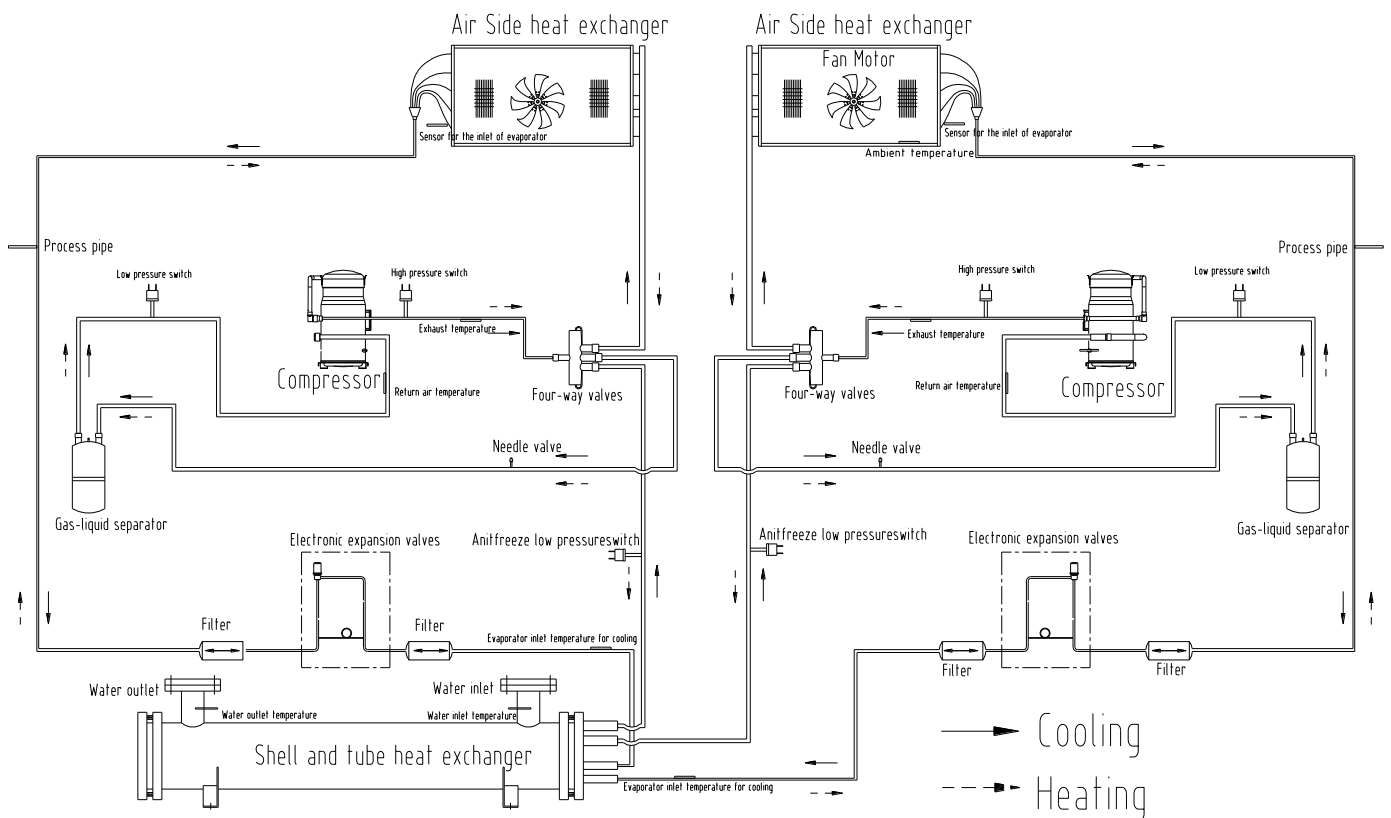

2.7. Explode View

NCX-H30 Exploded assembly drawings

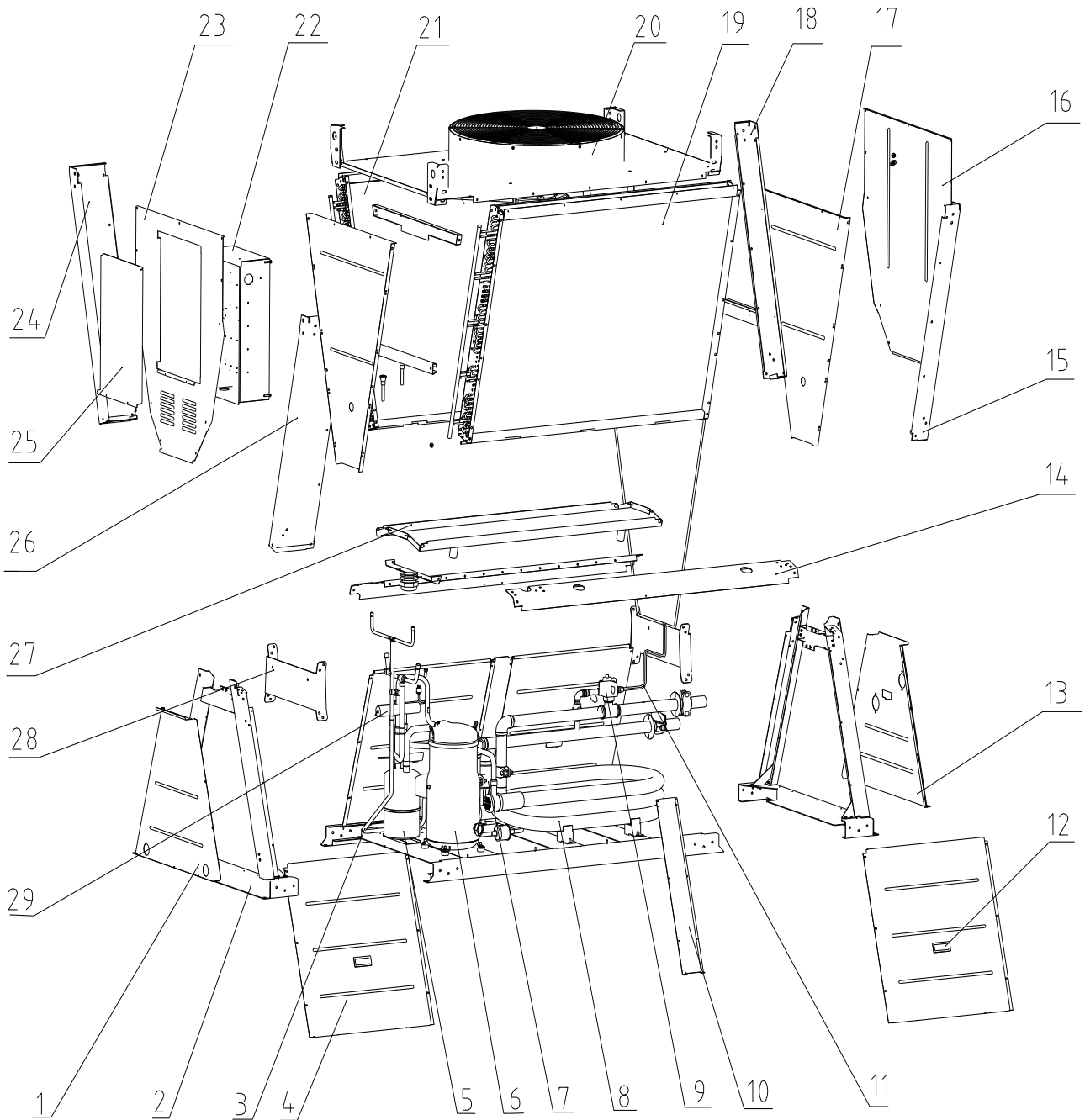

No.	Code	Chinese name	Part name	Quantity	Remark
1	16421001000036	LSQWRF65MX/D2 后外壳板	Back shell plate	1	
2	16321010000013	LSQWRF65MX/D2 底座组件	Bottom components	2	
3	16325010000408	ACMC-H100A5/XBSR1 液管组件	liquid pipe assy	1	
3.1	16441014000016	电子膨胀阀阀体 VPF-30D19	Electronic expansion valve body	1	
3.2	16441015000005	电子膨胀阀线圈 EPF-24D87 L=3100	Electronic expansion valve coil	1	
3.3	16442001000009	过滤器 $\phi 16 \times \phi 16-118$	Filter	2	
3.4	14514003000350	管 TP2M 高精级 3.5x2.0x600(伸4)	High-precision tube TP2M	1	
4	16421004000224	ACMC-H100A5/XBSR1 面板	Panel	4	
5	16442023000001	气液分离器 QFQ-5.3L(28.6-28.6)	Gas-liquid separator	1	
6	16438001000058	压缩机 SH140	Compressor	1	
7	16442020000004	储液器 1.2L	Accumulator 1.2L	1	
8	16324010000096	SCE-30 套管式换热器总成 (R410a)	SCE-30 tube heat exchanger assembly	1	
9	16445032000001	靶流开关 HF68B	Target flow switch HF68B	1	
10	16421031000137	ACMC-H100A5/XBSR1 中间立柱	Middle column	2	
11	/	ACMC-H100A5/XBSR1 喷淋组件	Spray assembly	1	
11.1	16441012000011	电磁阀阀体 ZS-15	Solenoid valve body	1	
11.2	16441002000004	球阀 1/2in 外x1/2in(螺纹连接)	Ball valve	1	
11.3	16445018000005	水过滤器 DN15 40 目	Water Filters	1	
12	11320097000003	R45W/X 小挖手	Small hand-dug	5	
13	16421004000222	ACMC-H100A5/XBSR1 侧面板 A	Side panel	1	
14	16421022000241	ACMC-H100A5/XBSR1 中间横梁 A	Middle beam A	1	
15	16421031000034	LSQWRF65MX/D 上端右侧斜立柱 B	Top right inclined column B	1	
16	16421001000228	LSQWRF65MX/D 上端左侧板	Top left plate	1	
17	16421005000141	LSQWRF65MX/D 冷凝器封板	Sealing plate condenser	1	
18	16421031000036	LSQWRF65MX/D 上端左侧斜立柱 B	Top left inclined column B	1	
19	16324010000099	ACMC-H100A5/XBSR1 右冷凝器总成	Right condenser assembly	1	
20	16321010000192	ACMC-H100A5/XBSR1 顶盖板组件	Top cover plate component	1	
20.1	16421005000403	ACMC-H100A5/XBSR1 顶盖板	Top cover plate	1	
20.2	16444008000002	轴流风叶 TFE712 ϕ 130	Axial-flow fan	1	
20.3	16430001000005	室外电机 SW750C	Outdoor fan motor	1	
20.4	16421036000017	LSQWRF65MX/D 风叶网罩 I	The wind leaf nets I	1	
20.5	16421035000011	LSQWRF65MX/D 电机支架	Motor bracket	1	
21	16324010000097	ACMC-H100A5/XBSR1 左冷凝器总成	Left condenser assembly	1	
22	16330010000003	ACMC-H100A5/XBSR1 电气总成	Electrical assembly	1	
22.1	16322010000004	LSQWRF65MX/D 电控盒组件	Electrical control box assembly	1	
22.2	16421005000298	LSQWRF65MXH/D 电气元件底板	Electrical components baseplate	1	
22.3	16422001000093	控制板 LSMR-2C-SYC1	Control board	1	

22.4	16430002000001	断路器 DZ47-60C6	Circuit Breaker	1	
22.5	16427022000002	接地铜排 7 位	Ground copper bars 7	1	
22.6	16427001000038	端子板 4 位(660V 16mm ²)	Terminal Board	1	
22.7	16430007000158	温度传感器 50K3950 XH2 黑 2.5mφ6 铜壳	Temperature Sensor(black)	1	
22.8	16430007000165	温度传感器 20K3950 XH2 白 3m 铜壳(组件)	Temperature Sensor(white)	4	
22.9	16430007000002	温度传感器 15K3950 XH2 白 2m 塑封(组件)	Temperature Sensor(white)	1	
22.1	16430007000024	温度传感器 20K3950 XH2 红 2m 铜壳(组件)	Temperature Sensor(red)	1	
22.11	16422005000009	(ROHS)变压器 TDB-14-B2B	Transformer	1	
22.12	16430009000003	交流接触器 GC4-18/01KK	The AC contactor	1	
22.13	16430009000027	(ROHS)交流接触器 GC3-3201	AC contactor	1	
23	16421001000540	LSQWRF98MX/T 上端右侧板 1	Top right plate 1	1	
24	16421031000035	LSQWRF65MX/D 上端左侧斜 立柱 A	Top left inclined column A	1	
25	16421005000422	LSQWRF98MX/T 电控箱盖板 1	Electric cabinet cover plate	1	
26	16421031000033	LSQWRF65MX/D 上端右侧斜 立柱 A	Top right inclined column A	1	
27	16321010000191	ACMC-H100A5/XBSR1 接水盘 组件	Drain pan components	1	
28	16421003000058	LSQWRF65MX/D 中间加强板	Intermediate reinforcing plate	2	
29	16325010000406	ACMC-H100A5/XBSR1 四通阀 组件	Four-way valve assembly	1	
29.1	16442024000031	低 压 开 关 H20PS C 0.55/0.45(弯管)	Low pressure switch	1	
29.2	16441008000001	四 通 换 向 阀 阀 体 SHF-H35672-003	Body of four-way valve	1	
29.3	16441001000004	针阀 1/4in(弯管)(R410a)	Needle valve	1	
29.4	16441009000011	四通换向阀线圈 SQ-A2522G L=2000	Coil of four-way valve	1	
29.5	16442024000006	高压开关 H20PS D 4.2/3.3(弯 管)	High pressure switch	1	

NCX-H65 Explode View
Assembly explode view

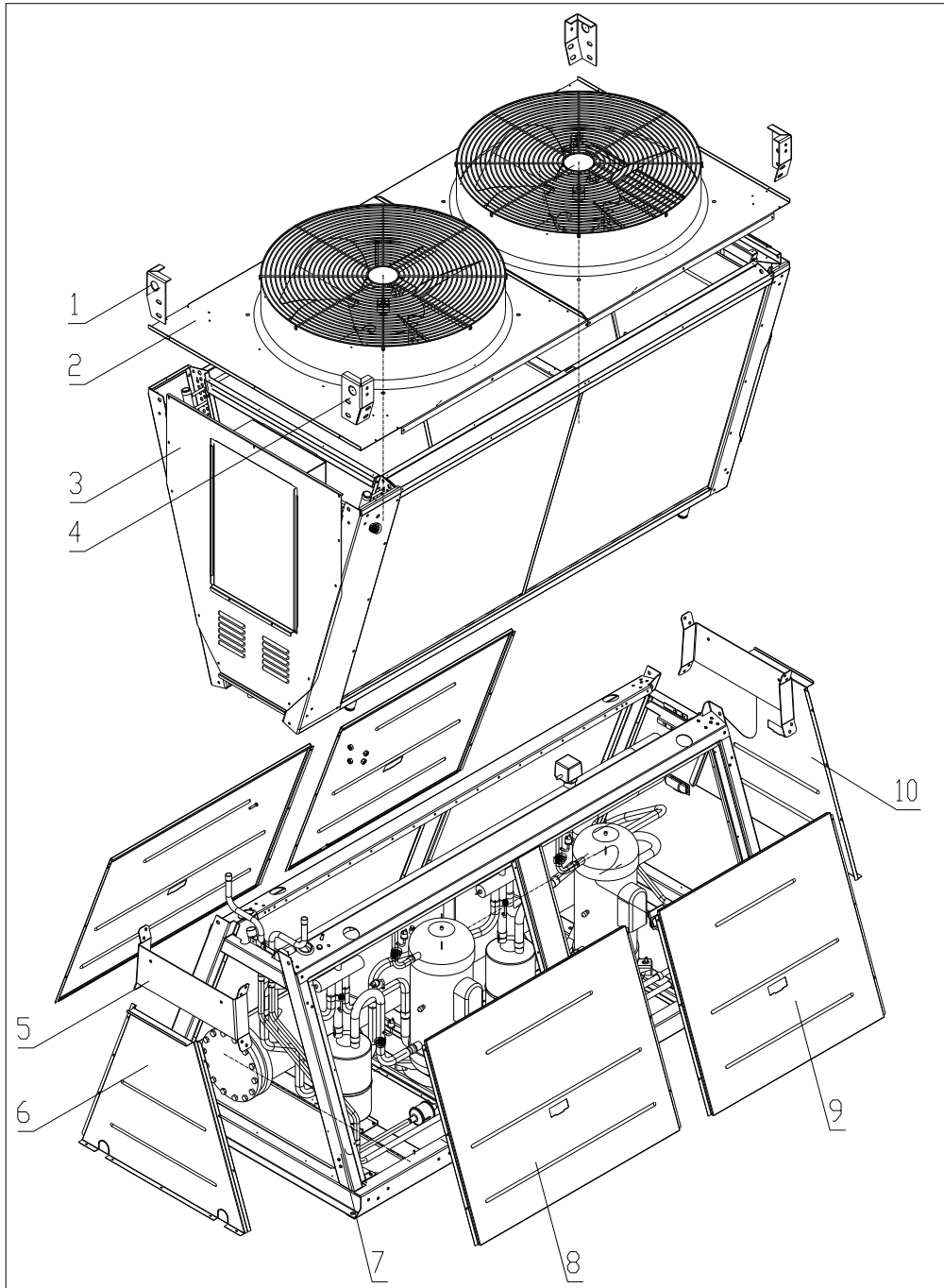

No.	Code	Chinese name	Part name	Quantity	Remark
1	1642102000001	LSQWRF65MX/D2吊装架A	Lifting frame A	2	
2	/	顶盖板组件	Top cover plate component	1	
3	/	上端组件	Top component	1	
4	1642102000002	LSQWRF65MX/D2吊装架B	Lifting frame B	2	
5	16421003000058	LSQWRF65MX/D中间加强板	Intermediate reinforcing plate	2	
6	16421001000036	LSQWRF65MX/D2后外壳板	Back shell plate	1	
7	/	下端组件	Bottom component	1	
8	16421001000226	LSQWRF65MX/D外壳侧板B	Shell side plate B	2	
9	16421001000034	LSQWRF65MX/D2外壳侧板A	Shell side plate A	2	
10	16421001000035	LSQWRF65MX/D2前外壳板	Front shell plate	1	

Top cover plate component explode view

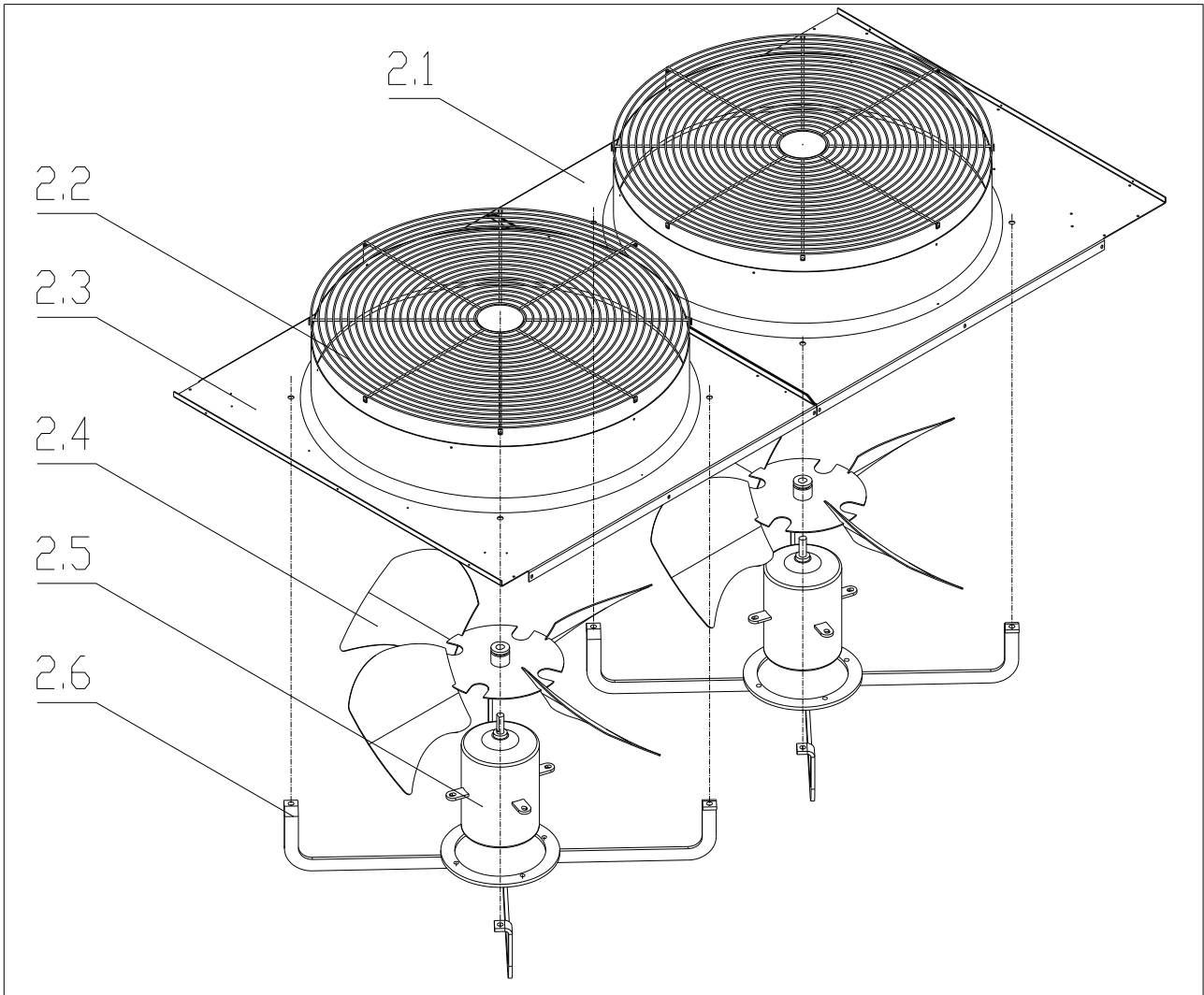

No.	Code	Chinese name	Part name	Quantity	Remark
2.1	16421012000083	LSQWRF65MX/D风机挡板A	Fan baffle A	1	
2.2	16421036000017	LSQWRF65MX/D 风叶网罩 I	The wind leaf nets I	2	
2.3	16421012000082	LSQWRF65MX/D风机挡板	Fan baffle B	1	
2.4	16444008000002	轴流风叶 TFE712 φ 130	Anxial-flow fan	2	
2.5	16430001000006	室外电机 SW750CL=2200	Outdoor fan motor	1	
	16430001000005	室外电机 SW750C	Outdoor fan motor	1	
2.6	16421035000011	LSQWRF65MX/D电机支架	Motor bracket	2	

Top sheet metal component explode view

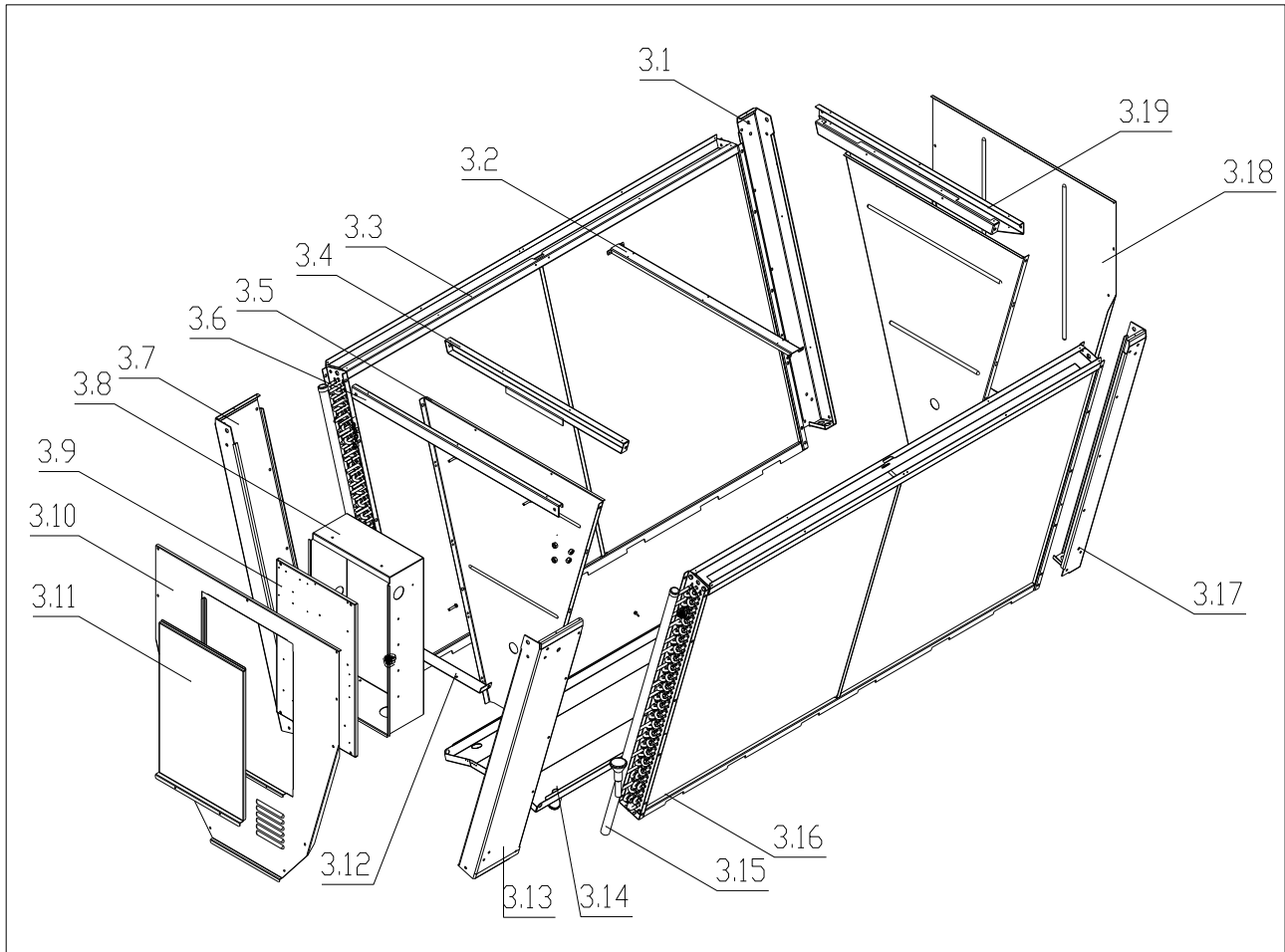

No.	Code	Chinese name	Part name	Quantity	Remark
3.1	16421031000036	LSQWRF65MX/D上端左侧斜立柱B	Top left inclined column B	1	
3.2	16421007000016	LSQWRF65MX/D风机挡板连接件	Fan damper connector	1	
3.3	16324010000079	ACMC-H220A5/XBDR1左冷凝器总成	Left condenser assembly	1	
3.3.1	16325010000361	ACMC-H220A5/XBDR1进气集管组件	Intake manifolds components	1	
3.4	16421024000099	LSQWRF98MX/T冷凝器上端固定条1	Top fixed strip for condenser 1	1	
3.5	16421005000141	LSQWRF65MX/D冷凝器封板	Sealing plate condenser	1	
	16421005000421	LSQWRF98MX/T冷凝器封板1	Sealing plate condenser 1	1	
3.6	16421002000106	LSQWRF65MX/D上端立柱固定条	Top column fixed strip	1	
3.7	16421031000033	LSQWRF65MX/D上端右侧斜立柱A	Top right inclined column A	1	
3.8	16421038000042	LSQWRF65MX/D电气箱体	Electrical cabinet	1	
3.9	16421005000298	LSQWRF65MXH/D电气元件底板	Electrical components baseplate	1	
3.10	16421001000540	LSQWRF98MX/T上端右侧板1	Top right plate 1	1	
3.11	16421005000422	LSQWRF98MX/T电控箱盖板1	Electric cabinet cover plate	1	
3.12	16421002000105	LSQWRF65MX/D冷凝器固定条	Fixed strip for condenser	1	
3.13	16421031000034	LSQWRF65MX/D上端右侧斜立柱B	Top right inclined column B	1	
3.14	16321010000048	LSQWRF65MX/D接水盘组件	Drain pan components	1	
3.15	16324010000080	ACMC-H220A5/XBDR1右冷凝器总成	Right condenser assembly	1	
3.15.1	16325010000361	ACMC-H220A5/XBDR1进气集管组件	Intake manifolds components	1	
3.16	16421031000035	LSQWRF65MX/D上端左侧斜立柱A	Top left inclined column A	1	
3.17	16421001000228	LSQWRF65MX/D上端左侧板	Top left plate	1	
3.18	16421002000103	LSQWRF65MX/D冷凝器立柱固定条	Column fixed strip for condenser	1	

Bottom sheet metal component explode view

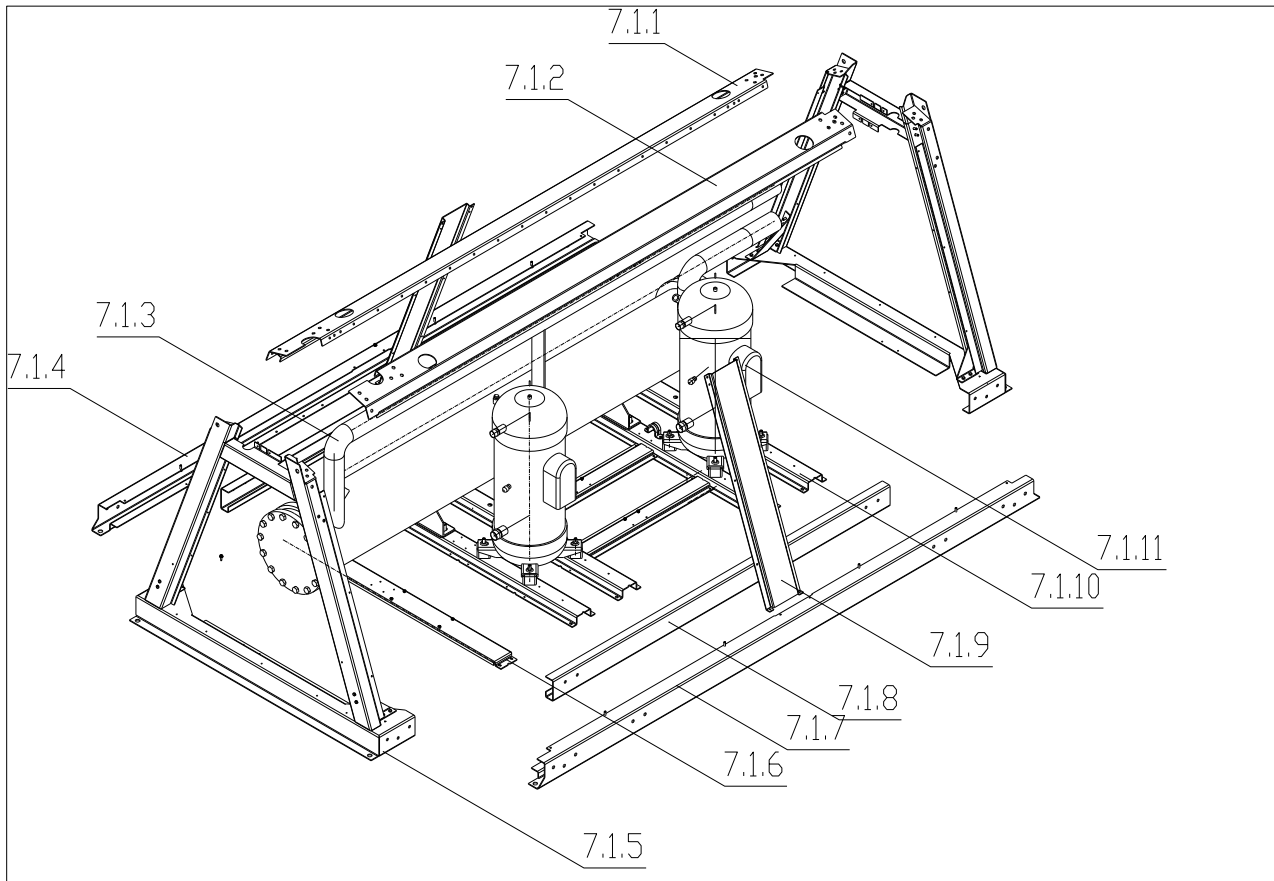

No.	Code	Chinese name	Part name	Quantity	Remark
7.1.1	16421022000089	LSQWRF65MX/D中间横梁A	Middle beam A	1	
7.1.2	16421022000090	LSQWRF65MX/D中间横梁B	Middle beam B	1	
7.1.3	16439004000095	壳管干式蒸发器 ACMC-H220A5/XBDR1	Shell and tube dry evaporator	1	
7.1.4	16321010000015	LSQWRF65MX/D2底座右长条组件	Bottom right strip components	1	
7.1.5	16321010000013	LSQWRF65MX/D2底座组件	Bottom components	2	
7.1.6	16421002000026	LSQWRF65MX/D2气分固定板A	Gas points fixed plate A	1	
	16421002000025	LSQWRF65MX/D2气分固定板B	Gas points fixed plate B	1	
7.1.7	16321010000014	LSQWRF65MX/D2底座左长条组件	Bottom left strip components	1	
7.1.8	16421003000162	LSQWRF65MX/D2底座加强板	Bottom reinforcement plate	2	
7.1.9	16421031000032	LSQWRF65MX/D中间立柱	Middle column	2	
7.1.10	16321010000199	ACMC-H220A5/XBDR1压缩机固定条组件	Compressor fixed components	4	
7.1.11	16438001000012	压缩机 C-SC903H8H	Compressor C-SC903H8H	2	

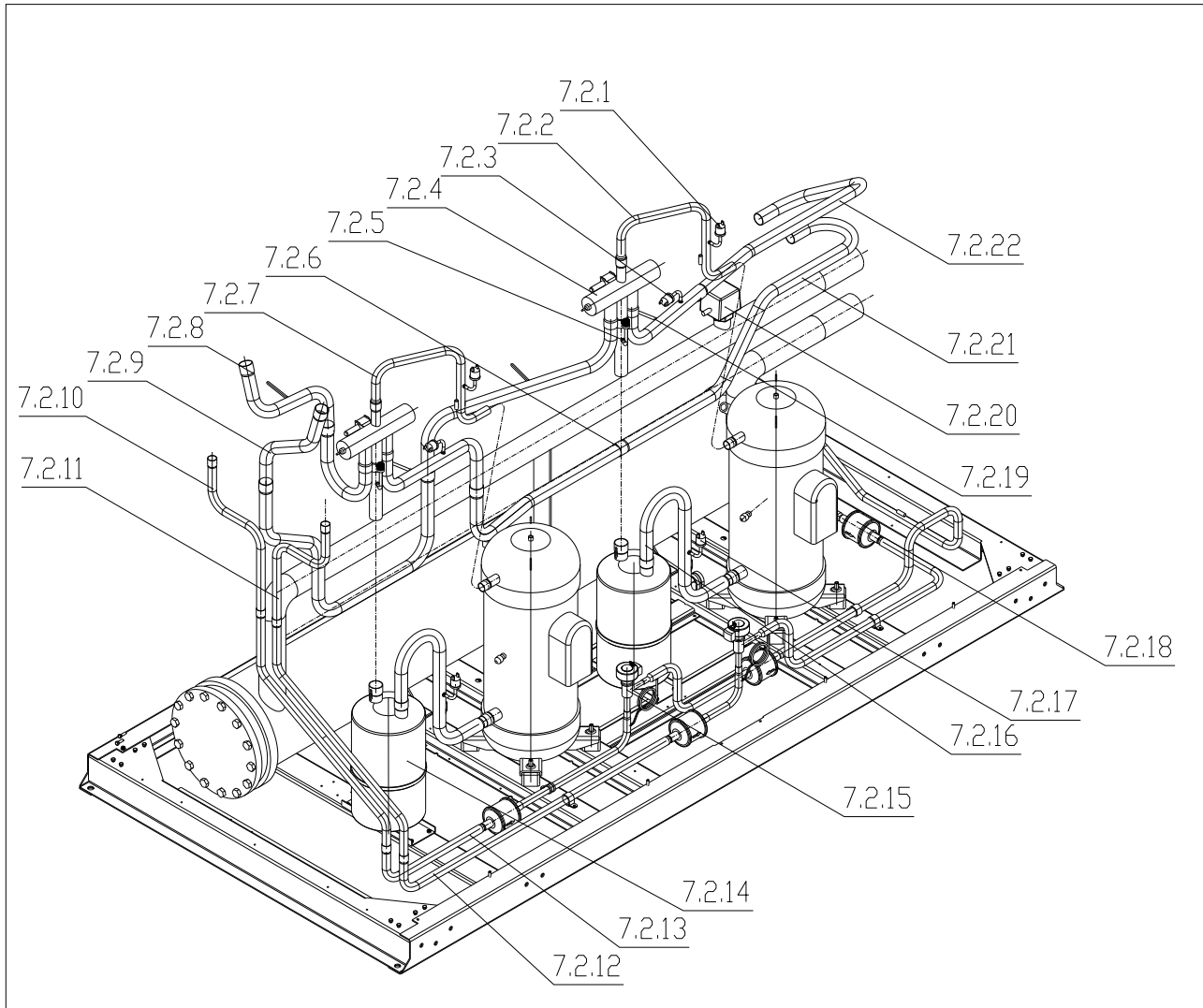
Bottom pipe component explode view

No.	Code	Chinese name	Part name	Quantity	Remark
7.2.1	16442024000006	高压开关 H2OPS D 4.2/3.3(弯管)	High pressure switch	2	
7.2.2	16325010000350	ACMC-H220A5/XBDR1 四通阀组件 B	Four-way valve components B	1	
/	16426017000107	ACMC-H220A5/XBDR1 四通阀至蒸发器接管B	Connecting pipe between 4-way valve to evaporator B	1	
7.2.3	16442024000009	低压开关 H2OPS C 0.48/0.28(弯管)	Low pressure switch	2	
7.2.4	16441008000001	四通换向阀阀体 SHF-H35672-003	Four-way valve body	2	
7.2.5	16441001000004	针阀 1/4in(弯管)(R410a)	Needle valve	2	
7.2.6	16426006000128	ACMC-H220A5/XBDR1 蒸发器回气管A	Evaporator back tracheal A	1	
7.2.7	16325010000349	ACMC-H220A5/XBDR1 四通阀组件 A	Four-way valve components A	1	
7.2.8	16325010000362	ACMC-H220A5/XBDR1 冷凝器进气管组件	Condenser intake components	1	
7.2.9	16426006000131	ACMC-H220A5/XBDR1 冷凝器进气管	Condenser intake	1	
/	16426006000138	ACMC-H220A5/XBDR1 冷凝器进气管B	Condenser intake B	1	
7.2.10	16426009000311	ACMC-H220A5/XBDR1 节流连接管	Throttling connecting pipe	1	
7.2.11	16426009000311	ACMC-H220A5/XBDR1 节流连接管	Throttling connecting pipe	1	
7.2.12	16325010000353	ACMC-H220A5/XBDR1 节流组件B	Throttling components B	1	

7.2.13	16325010000352	ACMC-H220A5/XBDR1节流组件A	Throttling components A	1	
7.2.14	16442023000001	气液分离器 QFQ-5.3L(28.6-28.6)	Gas-liquid separator	2	
7.2.15	16441014000006	电子膨胀阀阀体 EPF-32D86	Electronic expansion valve	2	
7.2.16	16325010000351	ACMC-H220A5/XBDR1压缩机回气管组件	Compressor back tracheal components	2	
7.2.17	16442024000005	低压开关 H20PS C 0.3/0.1(弯管)	Low pressure switch	2	
7.2.18	16442001000022	过滤器 $\phi 16 \times \phi 16-165$	Filter	4	
7.2.19	16426017000104	ACMC-H220A5/XBDR1四通阀至蒸发器接管A	Connecting pipe between 4-way valve to evaporator A	1	
7.2.20	16445032000001	靶流开关 HF68B	Target flow switch	1	
7.2.21	16426006000129	ACMC-H220A5/XBDR1蒸发器回气管A1	Evaporator back tracheal A1	1	
7.2.22	16426006000130	ACMC-H220A5/XBDR1蒸发器回气管B	Evaporator back tracheal B	1	

Part 3 Installation and Commissioning

3.1 Preparation before Installation

Before the building projects process, make sure the installation base of the chiller is ready, like reserving enough space for the pipe and pretask for installing the brackets, hanging brackets, cable and various protecting jackets.

◇ Acceptance

All the chillers will be packed with wood packaging, and the chillers will be charged refrigerant in advance. Users need not to charge it again.

When the cargo arrived, users should check the chiller and its accessories according to the packaging list, to make sure the chiller not damaged during the transportation and all the spare parts received.

◇ Transport

During moving the chiller to installation site from the warehouse, make sure the chiller is in vertical state before hoisting to avoid being hit or damaged.

No one should be allowed to stand under the chiller while hoisting.

The stay bars should have enough strength, and hoisting rope should be broad flat rope or soft steel wire rope with high strength. There should be protector between the hoisting rope and the chiller. The hoisting diagram is as follow:

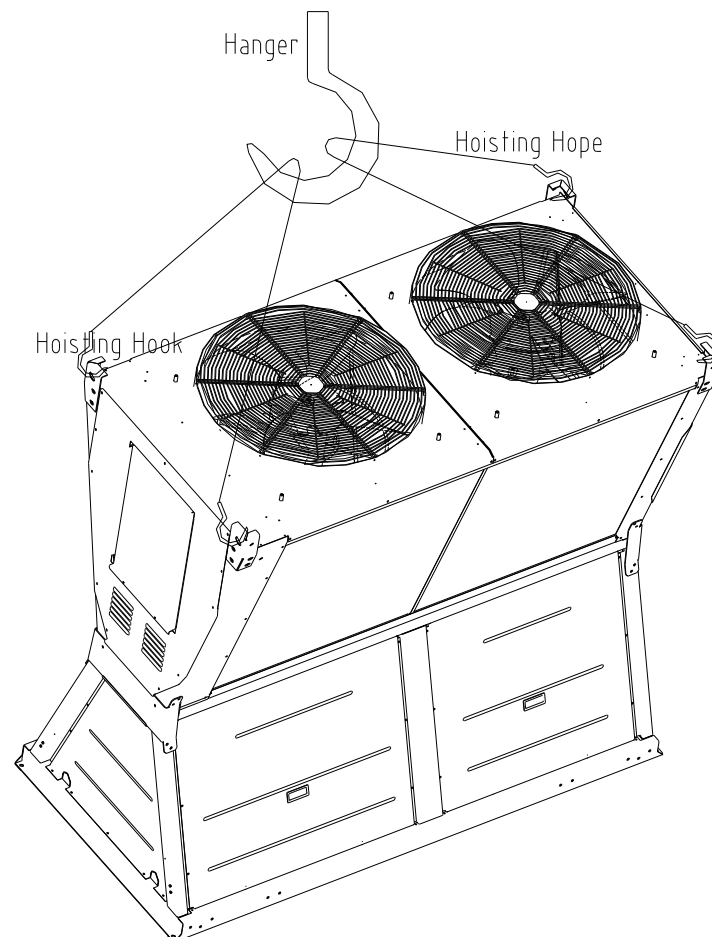

Chiller Hoisting Diagram

When the chiller is in its position, you can use forklift trucks or wireline hoist to move it. When use wireline hoist, the rope should be rolled around the chassis of the chiller, and you should also take measure to protect the surface and the side panels of the chiller.

While moving, the chiller should be kept in horizontal level, the angle of inclination should be less than 5 degree, avoiding the chiller damaged caused by rash operation.

The packaging dimension of the chiller foundation

(go to "Physical Dimension of the Chiller " in Chapter I for specific info)

3.2 Installation of the Chiller

Selection of Installation Location

- ◇The installation location should efficiently stand the weight of the chiller, like big terrace, rooftop, specific platform or any other places where are easy to install and strong enough.
- ◇The installation location must be able to ensure good ventilation. There should be enough space for installation, maintenance and normal operation. Check the installation diagram for specific info:

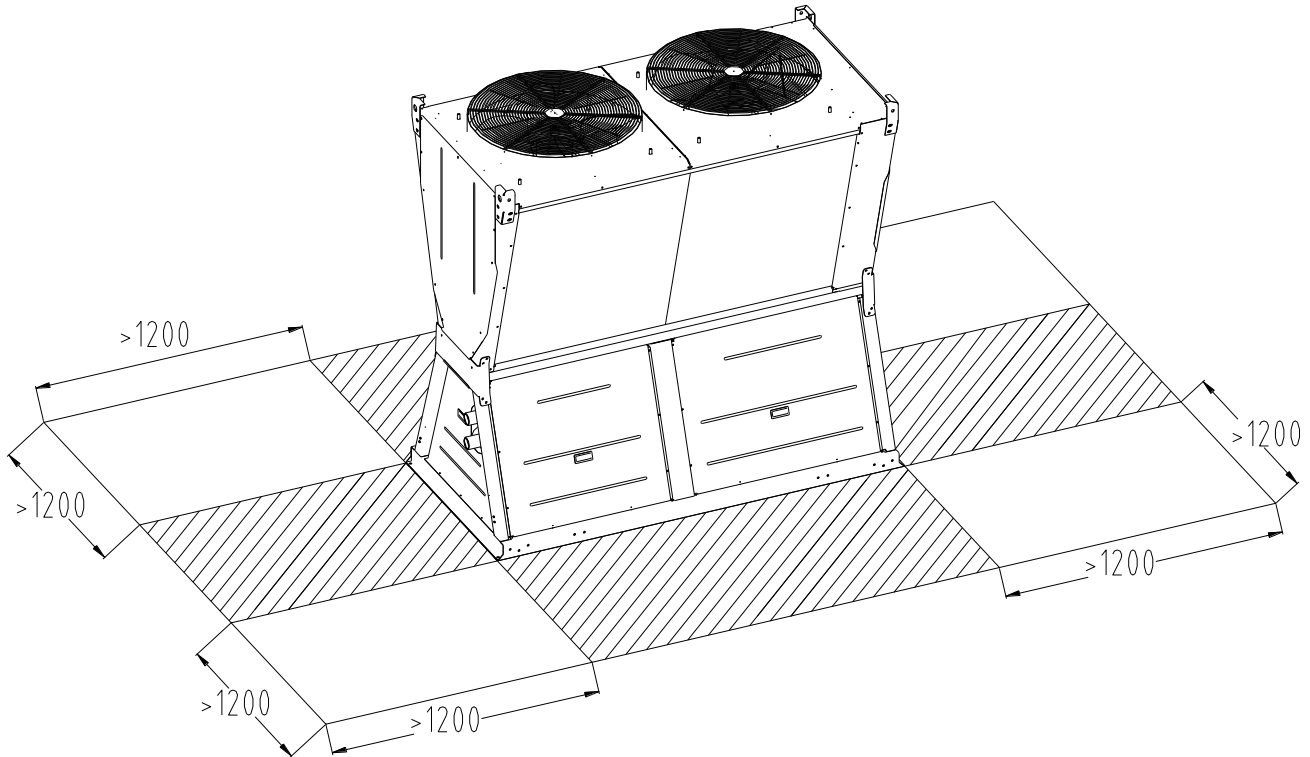

If the chiller will be installed under the eave or there is obstacles above the chiller, the following conditions should be agreed:

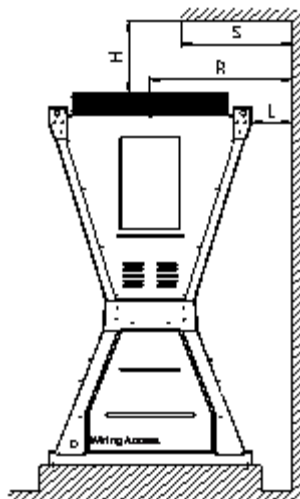

- (1)When installed under the eave, the condition will be agreed when $H \geq 3000\text{mm}$;
- When $1000\text{mm} < H \leq 3000\text{mm}$, $R \geq S$,
- When $H \leq 1000\text{mm}$, $L \geq S$.

Do not install the chiller near limited places like ventilation shafts and courtyard, in case the echo caused by the wall increases noise of the chiller, or the hot (cold) air discharged by the chiller influences its performance

- ◇The installation location should keep away from places with hot source, inflammable gas and aggressive gas

- ◇ The installation location must be able to ensure the chiller with protective measures and make children untouchable.
- ◇ The installation location should keep away from places with tree branch, fallen leaves and insects, to keep the condenser from blocking and the fan from damaging.
- ◇ The installation location must be able to ensure enough space for pipe, water box, valve and electricity.
- ◇ The installation location must reserve space to drain water.
- ◇ Ensure the installation foundation is 300mm above ground level

Installation Notice

- The chiller can be fixed on an independent concrete foundation with anchor bolt and antivibration rubber blanket, and space must be reserved for draining water.
- See the picture below for detail

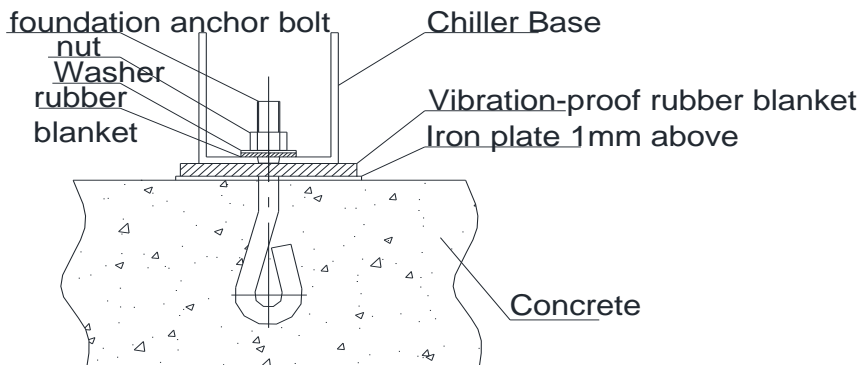

Pic2: Concrete and anchor bolt

- You can also make a steel spreader with angle steel or channel steel, and add vibration-proof rubber blanket to it, then fix them on concrete ground, terrace, rooftop or outdoor passage to make sure the chiller put in horizontal position.
- Ensure all the power line and signal line distributed canonically and professionally, and the electrical connection accurately and reliably.

Installation Diagram of the Chiller

Installation Diagram of the Chiller I (single chiller installation foundation)

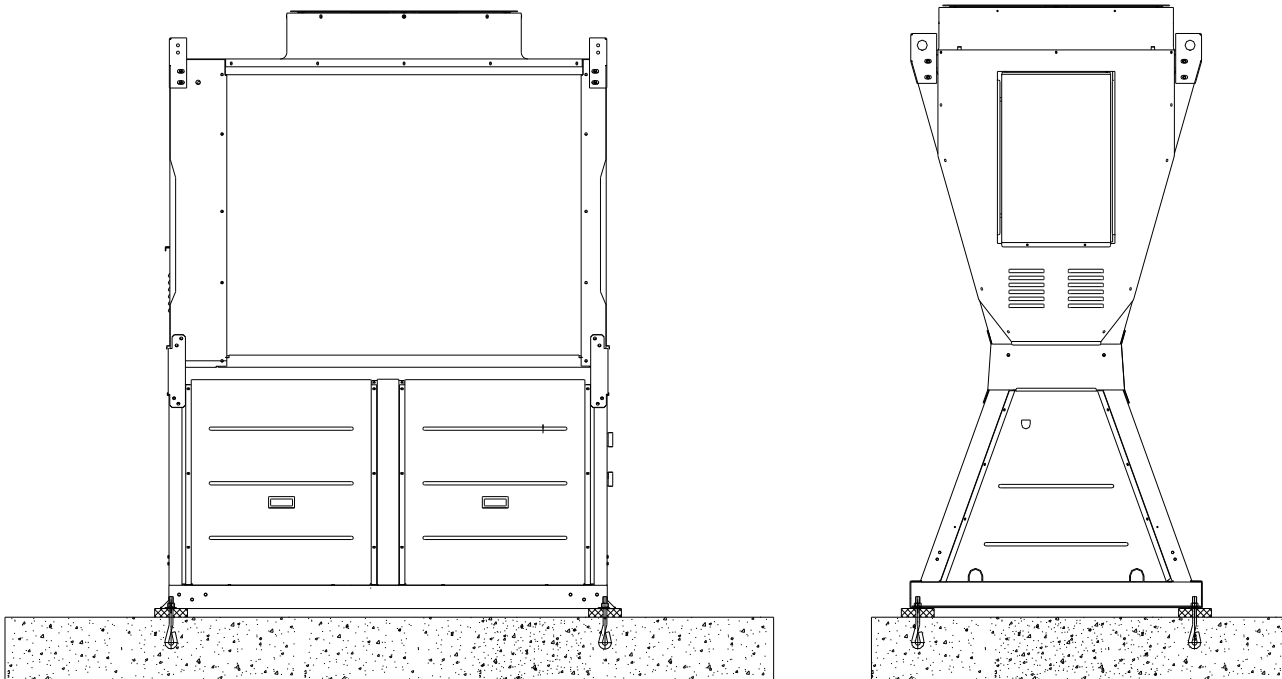

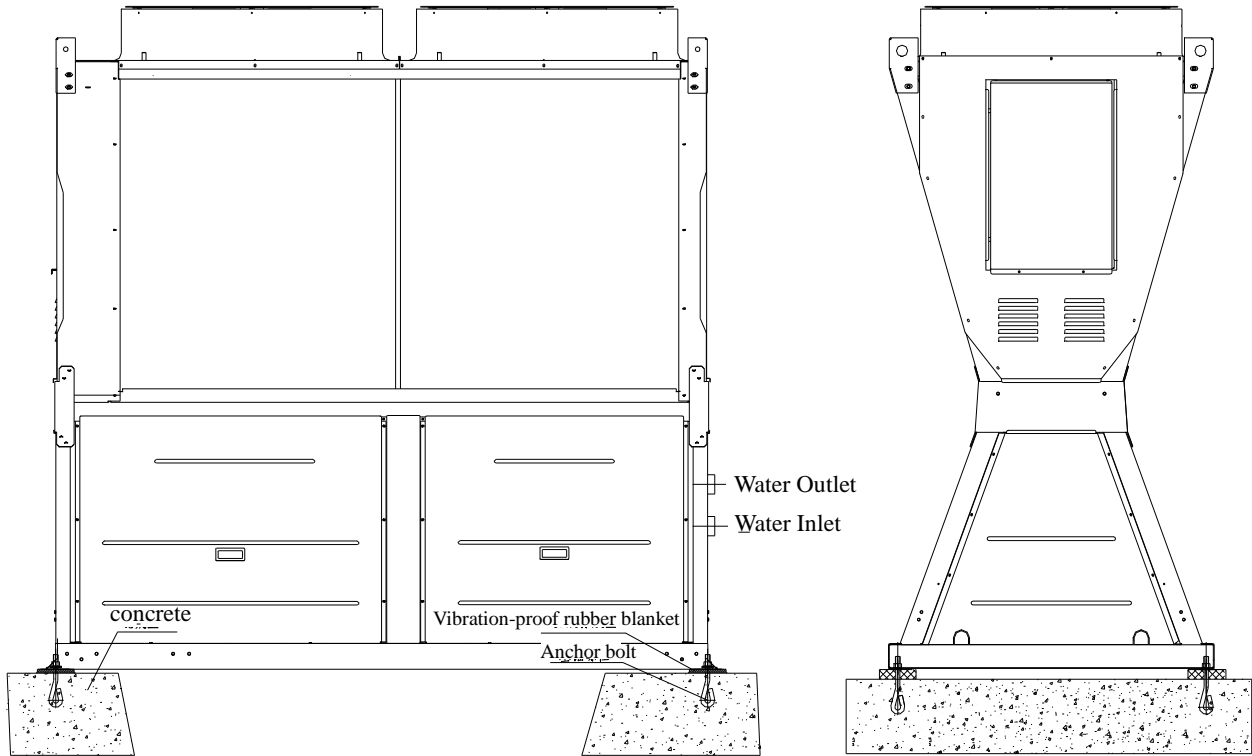

Installation Diagram of the Chiller II (Chillers Reverse Return Connection)

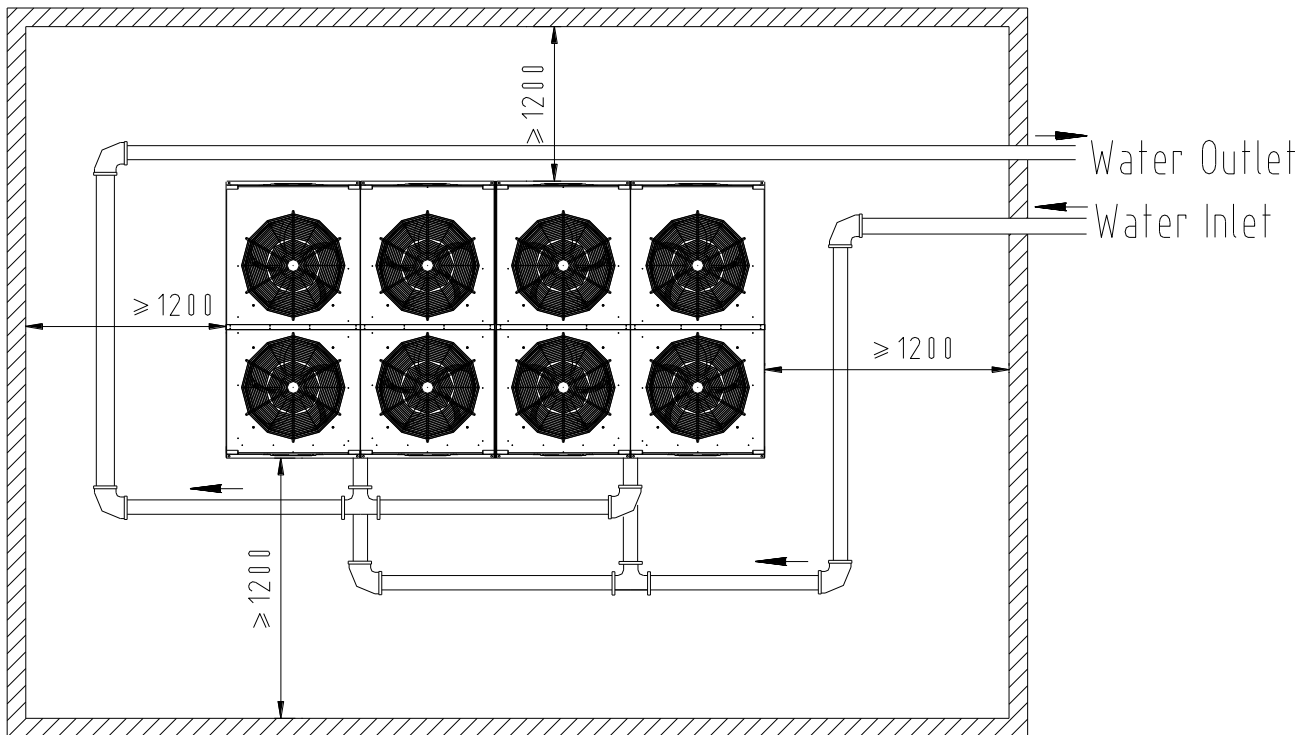

3.3 Installation of the Water System

Installation Notice of the Water System

- Vibration-proof soft connector and valve usually added to the joint of the chiller's inlet and outlet pipe, to avoid the chiller damaging the pipe because of vibration;
- Closed water system: waterway safety valve and auto water-makeup valve must be installed in the system. They should be installed on the inlet pipe of the water pump. Ensure the auto air release valve installed (installed vertically) at the top of the water system (0.5 to 1.0 meter), and under the valve, a gate valve should be installed.
- The open water box should be installed at the top of the water system, and the system water volume controlled by the float adjusting valve. Auto water-makeup valve and waterway safety valve are not needed here. Ensure the auto air release valve installed (installed vertically) at the top of the water system (0.5 to 1.0 meter), and under the valve, a gate valve should be installed.
- No matter in theory or in engineering practice, at the peak of all the air bags which are easily gathering air in the water system should be set with auto air release valve. Furthermore, while installing the auto air release valve, some parts of the pipe should be increased (the diameter).
- Install a Y-type filter on the inlet pipe of the chiller (40/sq.in.), to avoid the dirt in the water system block water side heat exchanger and then damage the chiller. Ensure the water flow in right direction in installation, and install stop valves at two sides of the Y-type filter for easy disassembly and cleaning (for the filter) Recommendation: Users better install electrical cleaner with relative specification in the water system, to ensure the chiller in good operation mode for a long time.
- The temperature sensor and pressure gauge should be installed at the straight parts of the chiller's inlet and outlet pipe (Do not install them at the elbow) for easy inspecting the operating state of the chiller. The sensor probe of the temperature sensor must be directly inject into the flow water in the pipe to ensure the accuracy of the water temperature. And a manual air release valve must be installed at the joint of the pressure gauge and the pipe for releasing air anytime and keeping the system stability.
- Install a drain valve (cleaning valve) at the bottom of the chiller's inlet and outlet pipe. The drain valve should be connected at the bottom of the system for easy draining water from inside the chiller and the chilled water in the pipe when in winter operation. In such way, it can prevent the cooled water freezing in the heat exchanger and the water pump, and then damage the chiller.
- In the North, the expansion water tanks or the auto water-makeup valve should be installed inside users' house, to prevent the water-makeup pipe and the valves from freezing in Winter operation.
- If the lowest temperature of the area in winter is below 0°C, then users should drain all the chilled water or add anti-freezing liquid into the system in Winter operation;
- The pipe of the water system should set independent bracket. Do not impose force on the chiller. Normally, the bracket space is based on performance of the material and size of the pipe diameter. PP-R pipe within 0.8 to 1 meter should be fixed with bracket.
- The straight pipe should keep certain grade for easy releasing air, and any leakage is not allowed both in the pipe and the connecting parts.
- In installing the pipe, the valve switcher must be flexible and undamaged, and the valve stem must not be bend.
- On the horizontal level pipe, the valve stem should be installed upward vertically or inclined upward for easy launching. Do not install the valve stem downward. The valve stem should be installed vertically to the wall under the vertical pipe.
- When the terminal system has solenoid valve and electrical valve installed (ie VRV System), the main pipe should install differential pressure valve.
- The target flow switcher should be installed at the horizontal main pipe within 1 meter from both sides, which has no elbow, 3-way branch pipe or pipe reducer.

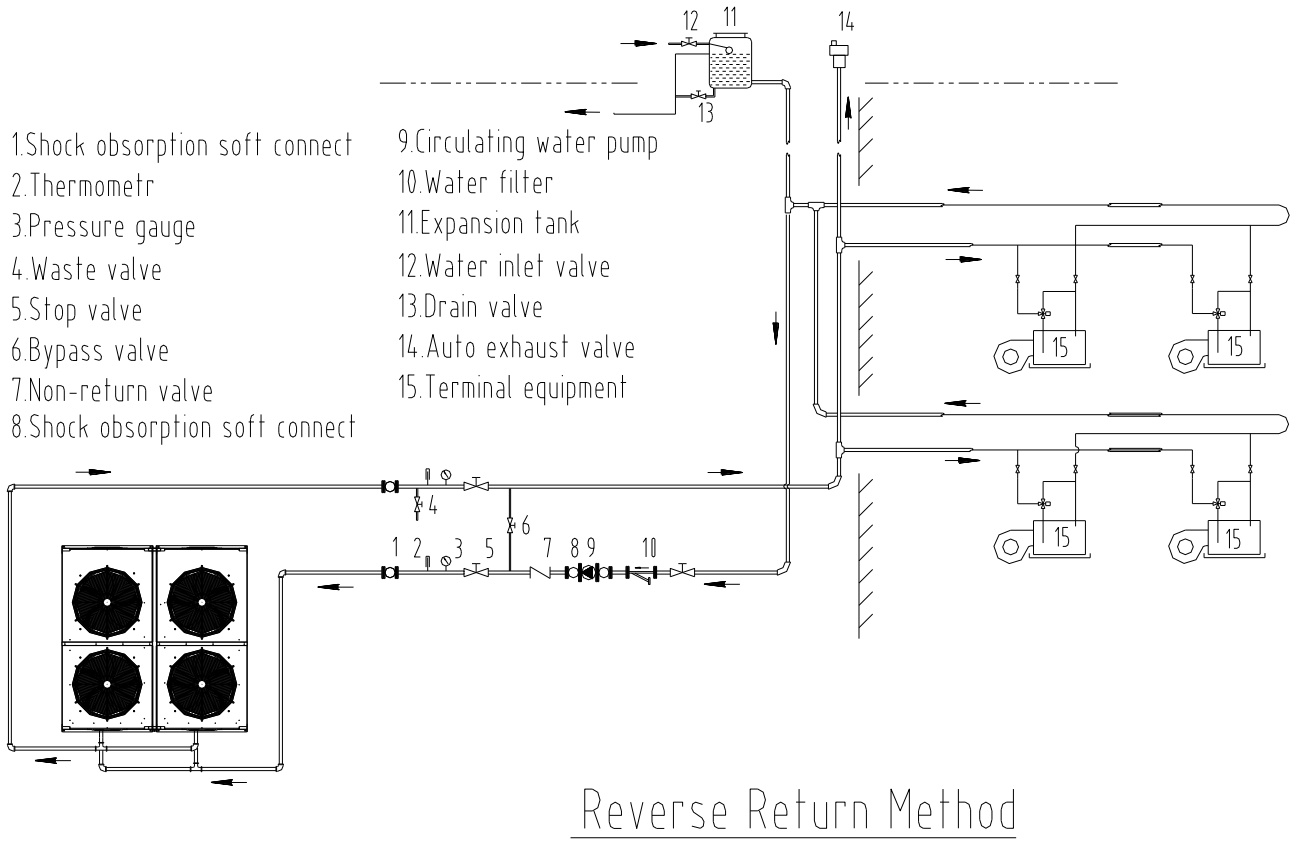

3.4 Electrical wiring

Notices of Electrical wiring

The electrical wiring must apply the rules of low voltage distribution equipment and circuit design. The power supply line should be equipped with low voltage breakers for short circuit protection: the breaker's rated current should be at least one level higher than the units' maximum operating current, and the breaker's setting current that instantaneously passes the current release must be less than the chiller's short circuit current's 1/1.3.

◇Power requirements

- ① Units power should employ the special power supply system, the total power capacity must exceed the corresponding power of the maximum operating current.
- ② Units power type: three phase five line:380V 3N~/50Hz.
- ③ The allowed power voltage fluctuation±10%,voltage unbalance less than 2.25%,

$$\text{Voltage Unbalance rate} = \frac{\text{The maximum voltage value} - \text{the average voltage value}}{\text{The average voltage value}} \times 100\%$$

- ④ Each module needs to be equipped with a special breaker.

Model	NCX-H30	NCX-H65
Circuit breaker settings (Ir)	35A	70A

◇Power line connection requirements

- ①For the three phase power, please respectively use yellow.green.red.light blue and yellow/green lead wire corresponding to L1.L2.L3.N.PE.
- ②The communication line and the power line could not be laid together.(the recommended communication line is the one uses copper core---≥0.25 mm shielded twisted-pair wire,less than1000m)
- ③When installing the power line, please check the phase order. Using wring terminal for tightening and then firmly connecting to the units power-line binding post; otherwise, catastrophic consequences such as units' breakdown or even fire can be resulted due to overheat.
- ④After finishing the installation of power line, please check carefully contrasting to the electrical wiring diagram. The power can be on only when the connection is right.
- ⑤Grounding requirements

The units must ground in a reliable way. The choice of ground wire commonly follows the following rules:

The cross-sectional area of ground wires

The cross-sectional area S of phase line (mm ²)	Ground wire (mm ²)
S≤16	S
16<S≤35	16
35<S≤400	S/2
400<S≤800	200
S>800	S/4

Recommended power line specification

(1) Single module unit power line specification and power line choice

model	NCX-H30	NCX-H65
Phase line diameter(mm ²)	10	16
Ground line diameter(mm ²)	16	16
Null line (mm ²)	16	16

- (2)Length commonly refers to the cable length between the chiller and the special power. In the commercial central air conditioner, the choice of wiring must consider its length to ensure the motor's start voltage drop within 2% of the rated voltage.
- (3)The cable assembly and material purchased must confirm to the national standard and only copper wires are allowed.
- (4)The cables must be copper core wires with temperature resistance not low than 75°C.
- (5)The cables should be chloroprene rubber sheathed wire, namely in the GB5013.2 chart No. 18, YZ.YZW pattern.

Electrical connection

Remove the units' access panel, connect power line L1, L2, L3, N and ground wire respectively to the power terminal L1, L2, L3, N and grounding symbol of the units electrical box, connect the control line of the controller (accessories with units) to the units' control board.

3.5. Trial operation

Hydrostatic pressure test, heat-preservation of the water pipe

Hydrostatic pressure test

◇After the installation of tube system.chiller.terminals.auxiliary parts.electrical etc., a hydrostatic test should be undertaken to check the sealing performance of the water system.

◇test pressure: “when the operation pressure $\leq 1.0\text{MPa}$, the test pressure should be 1.5 times of the operation pressure; the lowest pressure should not be less than 0.60MPa ;

When the operation pressure $> 1.0\text{MPa}$,the test pressure should be 0.5MPa plus the operation pressure; For the systems installed in tall buildings, floor by floor test is required.

◇When testing, the manual pressure testing pump should be connected. First drain the water and exhaust the air, then close the inlet/outlet water valve of the chiller, turn off the power and close the auto air exhaust valve, finally the pressure test of the water system can be started.

◇Fill the tube with water, add pressure to the tube using manual pressure testing pump, and observe if there is any leakage within one hour. Add pressure to the system after ensuring there is no leakage, and stop when the pressure gauge shows $1.0\sim 1.2\text{MPa}$. Write down the pressure value and keep this pressure for at least six hours.

◇Finally make sure that there is no leakage in the pipe system and each of its connection. If there is leakage phenomenon discovered, deal with it timely, and then do the pressure test again till the pressure value remains unchanged.

Heat preservation of the water pipe

After ensuring there is no leakage, the pipe system, valves on the system and the connections must firstly be treated with antirust in their welding spots, and then be well insulated to prevent cool & heat loss and creating condensate water in the surface. There are many kinds of insulation material; however, what commonly used are rubber and plastic insulation cotton, glass wool, rock wool, soft polyurethane foam plastics and so on.

The economic insulating thickness of the cold water supply pipes

The economic insulation thickness of the cold water pipes follows the national standard GB50189-2005,and should not be less than the figure listed below:

Insulation material	Cooling-supply time per year/h	The nominal diameter/mm	Economic insulating thickness /mm
Rock wool tube shell	2880	15-150	30
		200-350	40
Glass cotton tube shell	3600	15-150	30
		65-350	40
Rubber insulating tube	4320	15-80	40
		100-350	50

◇The economic insulating thickness of the hot water supply pipes

The economic insulation thickness of the hot water pipes follows the national standard GB50189-2005,and should not be less than the figure listed below:

Insulation material	The nominal diameter/mm	Economic insulating thickness /mm
Rock wool tube shell	15-25	20
Glass cotton tube shell	32-150	30
Rubber insulating tube	200-195	40

NOTES:

cool & heat dual water supply pipe is generally in accordance with the economic insulation thickness listed in the table “**The economic insulating thickness of the cold water supply pipes**”.

◇Each connection accessory should also be insulated, and pay attention to wrapping the metal piece exposed in case of condensed water.

◇The surface of the insulation layer should be smooth, without fragmentation, disjunction, looseness, or condensation and leakage and other problems!

System Cleaning and cooling water charging

◇After installing air-cooled (heated) chiller, the whole water system should be cleaned.

Close the stop valve and open the by-pass valve. Let the water pump run some time (10minutes or so), and clean the water filter; trying this for several times. On ensuring the outside circulating water system is clean without sundries, let the water pump run more than 12 hours. Finally open the stop valve, close the by-pass valve, the chiller will run normally.

◇Use the processed and clean tap water as the refrigerating medium of the circulating system—cooling water, and fill it into the water system from the water return pipe till the whole system is full, and then empty the air in the water system.

Note:

When filling the water, the vent valve of the system must stay open, and after filling close the manual vent valve.

Examination before trial operation

Check the power and the connection of the electrical control system

- (1) Before the first start, check whether the power distribution capacity is consistent with the units' power or not, whether the diameter of the chosen cable can bear the units' maximum current.
- (2) Check whether the power system conforms to the units, the units' power pattern: three-phase five lines (L1.L2.L3.N.PE,380V 3N~/50Hz),and check whether the phase order is right or not.
- (3) Check the power supply line of compressor; fix it tight again if it is loose. Otherwise it will lead to damage of the AC contactor or even the compressor.
- (4) Use megameter to measure the end of phase line and the motor winding are insulated against the ground, provided that the resistance not less than 10 MΩ; To measure the compressor winding is insulated against the ground with the resistance more than 2MΩ. Check whether the grounding line is installed correctly and reliably or not.
- (5) Check whether the power line is consistent with the capacitor request or not.
- (6) Check whether the power line is equipped with circuit breaker or not.
- (7) Check the external connection contrasting to the wiring diagram(the connection of target flow switch, the united control of water pumps and so on), check whether the internal and external (especially each connection) of the electric cabinet is clean or not.
- (8) Check whether the outside system conforms to the operation terms before turning on the chiller; for the water pump using external control, run the water pump before starting the chiller.
- (9) If the trial operation is undertaken when the main circuit breaks, check whether the electrical components function normally or not.

Check the terminal(fan coil)

- (1) Check whether all the power and control connection of the indoor fan coil is right or not, and whether the fan coil runs smoothly and flexibly or not.
- (2) Check whether the stop valve and the flow regulator valve in the inlet/outlet of the fan coil are open or not.
- (3) Check whether the air in the fan coil is empty or not; if not, it will make noise, then the manual vent valve should be turned around to empty the air, and do not close it till stable water flow out.
- (4) Check whether there exist sundries in the water plate of the Fan coil or not.

Check the chiller

- (1) Check whether the pipe system inside the chiller are damaged or not in the process of transportation and carrying.
 - (2) Check fan door leaf whether conflicts with the fan fixed plate and fan defense;
 - (3) Check refrigeration system has pressure or not, whether has leakage of refrigerants;
 - (4) Check compressor whether reheat more than 8hours (especially in winter test).
- ◇Check the pipe system
- (1) Check the valve in the system which should open, all open or not and stay in normal, and the valve should stop whether all turn off.
 - (2) Check all the connections of the tubing existing condensed water leakage.

- (3) Through the director of the pressure gage, check.adjust the system water pressure reaches the design index or not(standard needs more than50KPa),automatic filling valve runs normally or not.
- (4) Check whether the pipe system insulates well or not.
- (5) Check whether the pipeline system clean, when necessary, repeat washing.
- (6) The cold water fills the tubing or not, the air exhausts empty or not, and check the auto exhaust gas valve runs normally or not.

Each module controller’s address switch set

Heat pump unit module address switch set as follows:(the address switch shows in the red circle, indicates the address switch’s fact local.)

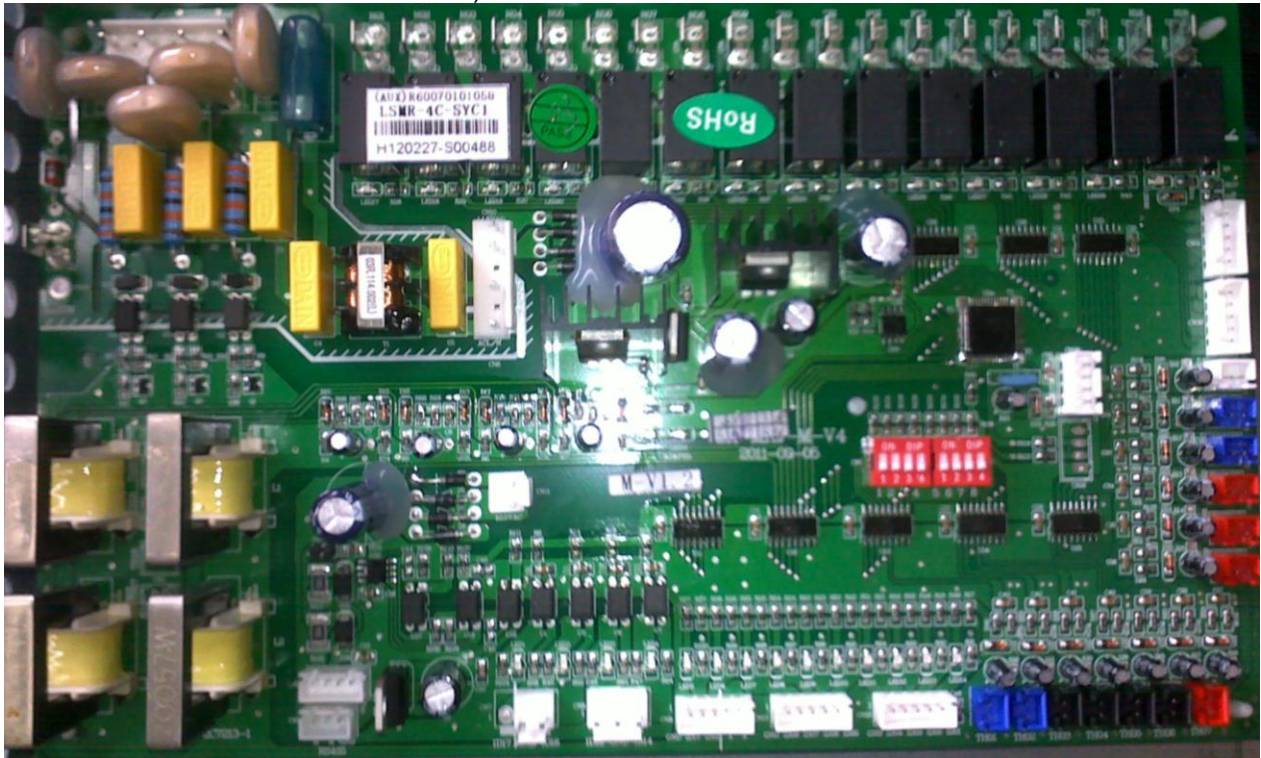

DIP1	DIP2	DIP3	Compressor No.	DIP4	Type	DIP5	DIP6	DIP7	DIP8	Address code	PCB No.
ON	ON	ON	3 comp.	ON	Heating pump	OFF	OFF	OFF	OFF	0000(0)	0# main module
ON	ON	OFF	2 comp.	OFF	Cooling only	OFF	OFF	OFF	ON	0001(1)	1# module
ON	OFF	ON	3 comp. &heat recovery			OFF	OFF	ON	OFF	0010(2)	2# module
ON	OFF	OFF	2 comp. &heat recovery			OFF	OFF	ON	ON	0011(3)	3# module
OFF	ON	ON	Retain			OFF	ON	OFF	OFF	0100(4)	4# module
OFF	ON	OFF	Retain			OFF	ON	OFF	ON	0101(5)	5# module
OFF	OFF	ON	4 comp. &130			OFF	ON	ON	OFF	0110(6)	6# module
OFF	OFF	OFF	4 comp. &65			OFF	ON	ON	ON	0111(7)	7# module
						ON	OFF	OFF	OFF	1000(8)	8# module
						ON	OFF	OFF	ON	1001(9)	9# module
						ON	OFF	ON	OFF	1010(10)	10# module
						ON	OFF	ON	ON	1011(11)	11# module
						ON	ON	OFF	OFF	1100(12)	12# module
						ON	ON	OFF	ON	1101(13)	13# module
						ON	ON	ON	OFF	1110(14)	14# module
						ON	ON	ON	ON	1111(15)	15# module

Module unit parameters inquiry push modify key to choose the module address.

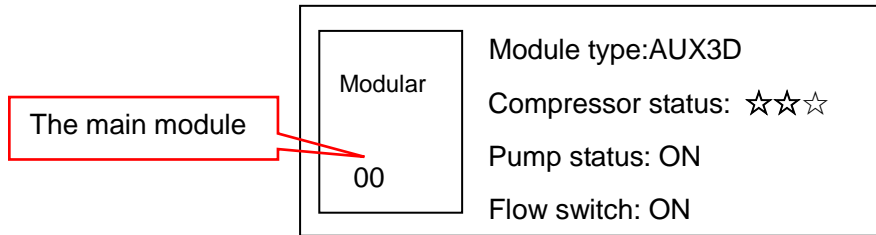

Each module’s controller only control themselves, but main module’s controller can control all the system besides controls itself. The control as follows:

- Water pump system controller;
- Flow signals controller;
- The water system ’s return water temperature controlling;
- the temperature of out water from system controller;

3.6 Commissioning

- ◇Turn on the power, run the indoor fan unit coil properly.
- ◇Turn on the pump, listen whether there are some noise in the pump, and watch the pressure whether in the normal level(the water pressure difference not less than50KPa).If appear flow switch protection, it turns out the flow pump too small, need find reasons and solve it.
- ◇Water valve pressure adjustment: when adjusting water valve, in case of high water pressure, which may lead to circulating water tank expansion, deformation even break. Turn the water valve pressure to the minimum(counterclockwise rotation),turn on the stop valve before the water valve, according to the water valve pressure, turn to the stipulated(0.1MPa or so).
- ◇For three phase power units, check fan. pump steering right or not, if not turn off the power right now, adjust the phase order. Test the compressor runs normally or not, whether exists some noise.
- ◇After put off, run the compressor, the unit stay in the normal working status, check the units have some vibration or abnormal noise, watch compressor inlet and outlet temperature changing, and check the unit current normal or not and record related to.
- ◇When the unit runs normal, the reference pressure documents of compressor inlet and outlet as follows:

Operation model	Exhaust pressure (MPa)	Suction pressure (MPa)	notes
Cooling	1.30~2.20	0.30~0.5	According to the specific temperature, environment temperature and flow
Heating	1.30~2.10	0.18~0.42	

Note:

In the debugging process, turn on the wire controller if find some unit break signal, refer to “break enquiry” of “wire controller set operation”, and eliminate the signal, ensure the unit no break, then start the unit ,continue debugging.

- ◇After running 30 minutes, water temperature stable and near to the valve stipulated, adjust water flow to name valve, according to the users’ load and water system fact situation set the water temperature, ensure the units run normally, end the debugging.

Note:

Because of the pump is controlled by the main unit controller, when run the water system, can temporary wiring to pump AC contactor control back Road electricity, in order to pump operation



warning:

1. Before water system unadjust well, forbid through main unit to run pump.
2. When brush the water system, must not run the unit.
3. Before water system exhaust air completely, must not run the unit.
4. Must install switch on the tubing, the water switch must connect with the unit, otherwise it will lead to stop when the unit running.
5. During the test run, after stop the unit less than 4minutes, must run the unit manual.

6. If not preheat enough to the compressor turn on the unit, may lead to compressor damage.

Protection and temperature control function test

◇Water flow switch protection test: when units run normally, turn off the backwater valve gradually, then the water supply will lower gradually, pressure lower, watch water switch cut or not to stop the unit, and show flow inadequate.



Note: Forbid turn down the flow switch controller or shorted the flow switch or route.

- ◇Refrigeration frost protection experiment: flow shortage and thermostat settings overflow, therefrigeration frost protection will start. So turn down the folw or the controller temperature lower , the unit will stop run.
- ◇Temperature control system test: In the refrigerate (heat) condition, turn off all the fan uint coil. When the backwater temperature less(more) than the set temperature(refrigerate 12°C, heating40°C), compressor uninstalation stop working. Then open the fan coil, increase (lower) the backwater, then the compressor can run normal and load start running.
- ◇More than 4hours when the units run, watch water temperature and its changing, and record adjust documents, if not in the normal range, check again(in normal situation, refrigerate temperature: 4~5°C, heating temperature:4.5~6°C),till the test return to normal.
- ◇According to room cooling (heating) effect, correspondingly adjust each room's fan coil flow control valve, so that each room water supply satisfy the need.
- ◇Normal running commonly 3days,watch the temperature changing whether meet the requirement..
- ◇Install electric two or electric three-way valve system, watch the electric valve whether adjust flow when working. If control not well should adjust timely.
- ◇When unit test running, after finish all the basic function test, should turn off the main unit, tear off test appliance, fix the electric terminal again, in case terminal loosen causes machine break, finally install the cover properly.
- ◇For ensuring the water system clean, need finally clear the unit inlet filter. Ensure units and system run normal, then can use the unit.
- ◇When units delivered to customers, test worker should instruct customers use as specification, which shows the operation stipulated, if need should show customers operation. till customers could use correctly.

The terms of units running

When units running normally, the flow of pump not less than name flow, if water flow less, units water temperature difference increasing(when normal running, units' water temperature difference commonly5°C or so),water flow protection lower than the water temperature then start protection to stop running, should timely find out the cause of less water flow, clear troubles then restart the unit.

Notices of Modular Chiller Normal Operation

- Only after trail operation and confirming that the chiller and the system operates smoothly, the cover board of the access panel can be fixed in place. And then the chiller functions.
- Several notices for users in using the chiller:
- Before using, check the condenser of the outdoor unit, and make sure there is not any leaf, cotton velvet, insect, shell or other pollutants. If there exist pollutants, they will not only add power consumption but also lead to halt due to high pressure. When cleaning the pollutants, vacuum cleaner can be used for exterior cleaning. Do not damage the aluminum cooling fin.
- Set the indoor room temperature at a proper figure, do not be too high or too low. A proper temperature will make your feel comfortable. The suggested room temperature for cooling mode is 23~28°C and for heating mode is 18~23°C.
- When turning on or turning off the chiller, please use the control switch and process step by step. Do not misuse the power switch for the chiller switch, or the system of the chiller will be damaged.
- Please keep other household electrical appliances (e.g. TV, radio, stereo etc.) at least 1m away from the indoor unit and the controller. Or the chiller will disturb the acoustic fidelity of the stereo and create noises.
- If the sun can shine through the window, please hang curtains or shutters to make sure the heat preserving effect when using the air conditioner.

- When the air conditioner is operating, please do not open the window or the door for long time, or the condensing water will be created in the air outlet.
- When the air conditioner is running, if unusual smell (e.g. smell of scorching) is smelt, please turn off the power at once and find out the cause.
- Do not clean the chiller when the power is on.
- In daily use, users should operate on the wired controller for turning on/off the chiller and for changing from cooling mode to heating mode.
- In snowy days, the chiller installed in the open air should be protected with coverings; if there is already accumulated snow on the chiller, it should not be started directly. It can be started when the snow is cleaned.

Notices of Modular Chiller Halt

- Operating normally, if the chiller is restarted after halting for human factors, the compressor will start in 3 minutes' delay. So please do not forcibly start the compressor by other means.
- Operating under the cooling mode, if users want temporary halt, please press the "on-off" button on the wired controller. To facilitate the heater heating up the lubricating oil, it is not necessary to cut off the supply power of the chiller



Warning

- Operating under the heating mode, if users want temporary halt, please press the "on-off" button on the wired controller. Or the chiller will not automatically enter the anti-freezing mode and will be damaged due to over low temperature of the water pipe.
- If the chiller is not used for a long time, either in season or out of season, please drain all the cooling water out of the chiller from the water outlet, and turn all power off.
- Operating under the heating mode in winter (especially when TA is lower than 0°C), please do not cut off the power of the chiller and the water pump. The water pump is not integrated with the chiller, thus it should not stop operating in order to prevent freezing.
- Please constantly check the working conditions of the inlet and outlet water temperature, the compressor, the fan motor and the water pump in the daily operation of the chiller.
- Constantly check the power supply condition, whether the electrical fittings operates smoothly or not and the cleanliness of heat exchanger. And then regularly clean the heat exchanger according to the real situation.
- Do not close the inlet and outlet water valve of the indoor fan coil at will when the chiller is operating; or the normal operation of the chiller will be influenced and the heat exchanger will be frozen.

3.7 Project Acceptance

Generally there are two acceptance phases for the installation and commissioning of central air-conditioning:

◇The preliminary acceptance process starts after the installation of pipelines and before interior decoration, mainly targets at concealed works such as indoor fan coil, water system piping, condensated water piping (flowing direction, sealing performance of fixed positions, heat preservation) and wire through pipes. Its objective is to let users confirm whether the installation of concealed works is consistent with the installation requirements and design standards or not; and to prevent mistaking the carelessness of decorators for the installation quality problem that leads to the damage of air-conditioning system in the late decoration.

◇The second acceptance process begins after finishing the whole project and commissioning the modular chiller for normal run, targeted at the installation correctness of pipelines and valves, and the cooling (heating) capacity. Upon the acceptance, the commissioning report will be filled in by both parties. And assistance will be provided for users to fill in the guarantee card. Meanwhile, guidance for using and maintaining the air conditioner according to the manual will be provided, with examples if necessary.

3.8. Grades and standards for refrigeration compressor oil-filled volume

Unit Type	Brand	Compressor Specification	Compressor oil grade	Oil volume(cm ³)
NCX-H30 NCX-H65	Danfoss	SH140	POE-160SEZ	

3.9 Operation and Maintenance

Interface Introduction of Wired Controller

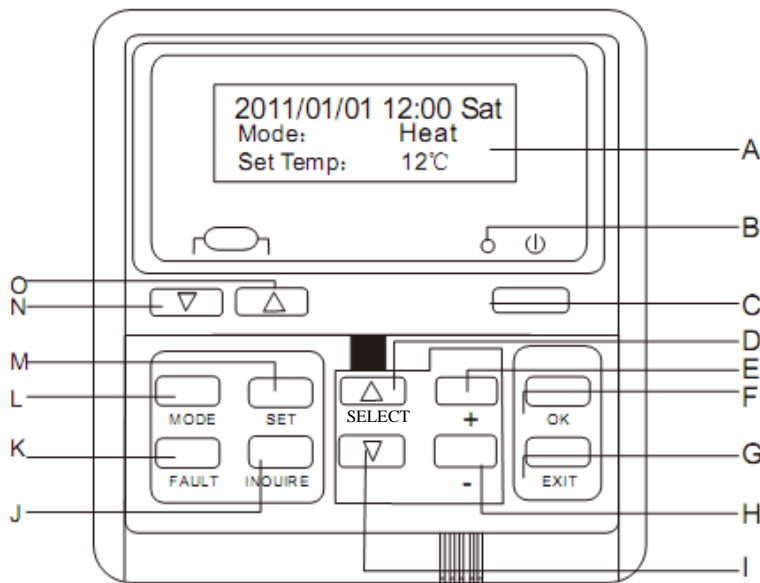

- A. Interface
- B. Power Led
- C. 【On/Off】 button
- D. 【SELECT +】 button
- E. 【+】 button
- F. 【OK】 button
- G. 【EXIT】 button
- H. 【-】 button
- I. 【SELECT -】 button
- J. 【Inquire】 button
- K. 【Fault】 button
- L. 【Mode】 button
- M. 【Set】 button
- N. 【Set-】 button
- O. 【Set+】 button

Operation Instruction of Wired controller

1. Power 【On/Off】

With the unit turned on, pressing 【On/Off】 button will immediately turn it off and the ON/OFF indicator will go out.

With the unit turned off, pressing 【On/Off】 button will immediately turn it on and the ON/OFF indicator will light

Illustration of the home screen after the unit is turned on:



(Figure 1)

The first line displays the date and time: yyyy/mm/dd hh:mm DAY(MON,TUE...).When the timer is active, a clock icon will appear on the upper right corner.

The second line displays the operation mode setting.

The third line displays the water temperature setting.

The fourth line displays the current trouble: nothing when there is no trouble or the last one when there are troubles.

Illustration of the home screen after the unit is turned off:

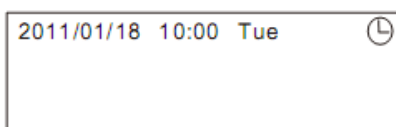

(Figure 2)

When the unit is turned off ,only time and troubles will be displayed.

Pressing 【On/Off】 button will turn on the unit, or if other buttons are pressed , the operation mode and temperature setting(without turning on the unit)will be displayed, for adjusting mode and temperature before turning on.

If no buttons are pressed within 5 seconds,the screen display will return to when the unit is turned off.

2. 【Mode】 button

Pressing 【Mode】button under the home screen will cycle the unit between “Cooling” , “Heating” and “Heating +Auxiliary heating ” modes.

3. Adjusting water temperature

Pressing 【Set+】 button will increase the water temperature setting and pressing 【Set-】 will decrease the setting.

The adjustment range of water temperature is 10~25°C for cooling or 25-45°C for heating.

You may want to speed up the adjustment by pressing and holding 【Set+】or【Set-】button for 2 seconds.

4. Changing/Setting Time

Under home screen, press **【SET】** key to open Setting Menu page , choose “Set Time” and press **【OK】** key to open Time Setting page.

Illustration of Setting Menu page

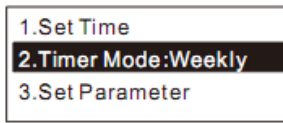

(Figure 3)

Under Setting Menu page,you can traverse the options by pressing **【Previous】** or **【next】** ,with the active one appear in reverse.

Illustration of Time Setting page

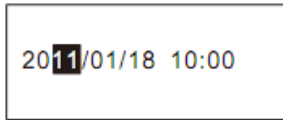

(Figure 4)

Under Set Time page,you may traverse the options by pressing **【Previous】** or **【next】** ,with the activated one appear in reverse , to which you can make change by pressing **【INC】** or **【DEC】** .

After the changings are made,press **【OK】** to make them valid and turn the screen back to Setting Menu page.

If during the process of making change ,the **【Exit】** key is pressed, the screen will return to home screen and the change won't take effect.

5.Timing Setting

Under home screen, press **【SET】** to open Setting .Choose Timer mode , then the type of timing currently selected will display to the right of the same line, which you may change to the type you intend to use by pressing **【+】** or **【-】** . Then, press **【OK】** to open corresponding timing setting page.

Under Setting Menu page, choose “Set Time” ,then select “Disable” through **【+】** or **【-】** to turn off the timing function.

The Setting Menu page is as shown in figure 3.

For this unit, timers are available in 3 modes: Current timing, Daily timing and Weekly timing. Only one of the 3 modes can be activated at one time.

5.1 Current timing

Illustration of Current timing

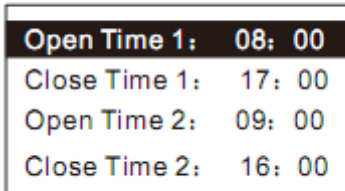

(Figure 5)

In Current timing mode, there are 4 timers,2 for turning on and 2 for turning off.

You may traverse the options by pressing **【SELECT +】** or **【SELECT -】** ,with activated one appear in reverse.

Through **【+】** or **【-】** ,the timing setting of the active timer can be changed.

You may want to speed up the changing process by pressing and holding either one for 2 seconds.

All timers can work at same time.

A Current timing work only for the current day and will be automatically set to “Disable ” the day after.If across-day

timing is needed, please use Daily timing or Weekly timing.

If 2 timing settings are identical and both are set for turning on(or off),only one of them will be executed.

If the unit is set to be turned on and off at same time, then the turning off order will be executed.

The timers are executed in the order of time . If the unit is currently at the state set in a timing as the target state, the order

that fulfills the state will be automatically ignored.

The above figure illustrates an example where the unit is set be turned on at 8:00 and off at 16:00 for the current day.

Special tip: If the set time precede the current time, the timer will be considered invalid.

5.2 Daily timing

Illustration of Daily timing

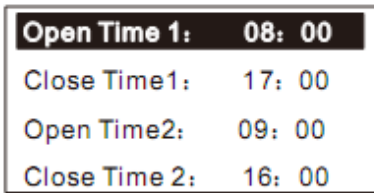

(Figure 6)

All timers can work at same time.

If 2 timing settings are identical and both are set for turning on(or off),only one will be executed.

If the unit is set to be turned on and off at same time, then the turning off order will be executed.

The timers are executed in the order of time . If the unit is currently at the state set in a timing as the target state, the order that fulfills the state will be automatically ignored.

The above figure illustrates an example where the unit is set to be turned on at 8:00 and off at 16:00 everyday.

In Daily timing mode, there are 4 timers,2 for turning on and 2 for turning off.

You may traverse the options by pressing **【SELECT +】** or **【SELECT -】** ,with the activated one appear in reverse.

Through **【+】** or **【-】** ,the timing setting of the activated timer can be changed.

You may want to speed up the changing process by pressing and holding either one for 2 seconds.

5.3 Weekly timing

Illustration of Weekly timing

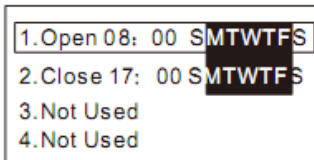

(Figure 7)

In Weekly timing mode,there are 8 timers with the activated one wrapped In a box.

“Open” and “Close” indicate whether a timer is set for turning on or off.

“Not used” means the corresponding timer doesn't work. “SMTWTFS” is the Day option,with each letter representing Sunday,Monday,Tuesday,Wednesday,Thursday , Friday and Saturday,respectively.

The letters appear in reverse indicate the days on which the timers work and the letters appears in normal way, the days on which the timers don't work.

Figure 7 illustrates an example where timer 1 is the active one with both timer 1 and timer 2 activated and others are inactive. The timing is as follows: The unit is set to be turned on at 8:00 and off at 17:00 from Monday to Friday. No operation is scheduled on Saturday and Sunday.

Through **【Previous】** or **【Next】** key, you may switch between timer1-8,with the selected one appear in a box, then by pressing **【OK】** key, you can open the adjustment page for that timer and make settings.

Week timer changing page

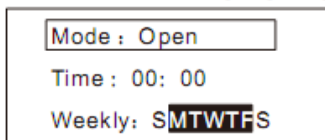

(Figure8)

The vertical box to the left displays the serial number of Week timer that is currently being changed.

The 3 lines to the right display respectively the operation mode selection,timiming setting and day setting.

The one that appear in a box is active.

1. Mode column: whether the timer is activated or not, or is an ON timing or OFF timing.
2. Time column : for setting the work time of the timer.
3. Day setting :for selecting the days on which the timer is supposed to be activated with those days appear in reverse.

You may traverse the options by pressing **【SELECT +】** or **【SELECT -】** ,with the active one appear in a box.

Press **【+】** or **【-】** to make changes.

After making all changes, press **【Exit】** to return to the screen at a higher level. Setting is done.

The operations of other Week timers are the same as above. After the setting is done, press **【Exit】** to return to home screen.

6.Operation state inquiry

Under home screen, press **【Inquire】** to enter the page of operation state inquiry for the unit.

The vertical box to the left displays the designation of the unit that is currently under inquiry.

Under Inquiry page, you may page up and down by pressing **【SELECT +】** or **【SELECT -】** .

Under Inquiry page, you may switch the data display between the modules through **【+】** or **【-】** key. The “↓” symbol indicates that there is a following page and “↑” indicates there is a precedent page. Press **【Exit】** to return to home screen.

Operation State Inquiry page



(Figure9)

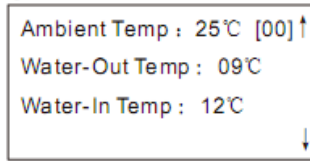

(Figure10)

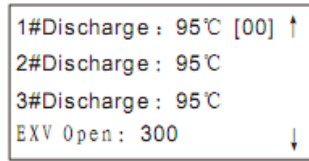

(Figure11)

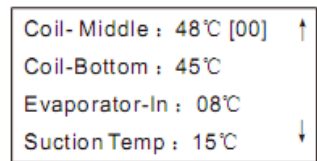

(Figure12)

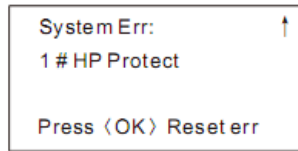

(Figure13)

In Figure 9, “★” denotes the compressor is activated and “☆” denotes the compressor is not activated.

The compressors are displayed ,from left to right,in the order of compressor#1,#2,#3 (if equipped).

If the screen displays as in figure 13, the trouble can be reset by pressing **【OK】** .

7.Trouble History Inquiry

Under home screen, press **【Inquire】** to enter the page of Trouble History Inquiry.

Under the Trouble History Inquiry page, you may select the troubles to view by pressing **【SELECT +】** or **【SELECT -】** .

The “↓” symbol indicates that there is a following page and “↑” indicates there is a precedent page. The active line appear in reverse and scrolls down the complete information about the trouble selected. The complete trouble information include the occuring time (yy/mm/dd/hh/mm),trouble code, name of the troubled unit and name of trouble.

Trouble History Inquiry pate

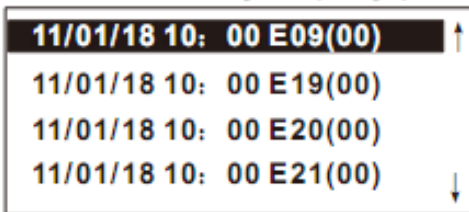

(Figure14)

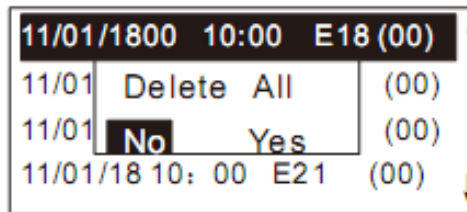

(Figure15)

Press **【Exit】** to return to home screen.

Under the Trouble History Inquiry page, if you press**【OK】**, aballoon as shown in Figure 15 will popup, you may choose to “Yes” or “No” by pressing **【SELECT +】** or **【SELECT -】** .

If you press**【OK】**after selecting“No” or simply press **【Exit】**,you will return to Trouble History Display page or

if you press**【OK】** after selecting “Yes” , you will delete all trouble history and return to the Trouble History Display page.

8.Parameter Setting

Under home screen, press **【SET】** key to enter Setting Menu page , choose Parameter and press **【OK】** ,a password entering page as shown in Figure 16 will display.

Password Entering page

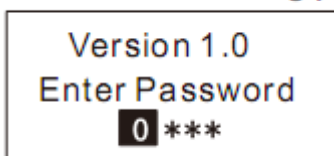

(Figure16)

While entering a password, you may traverse the digits to enter by pressing **【SELECT +】** or **【SELECT -】** ,with the active one appear in reverse.

Press **【+】** or **【-】** to choose the value to enter.

After the 4-digit password is entered, press **【OK】** to verify it. If the password entered id correct,you will enter the Parameter Setting page.

Under Parameter Setting page, you may choose the parameter to change by pressing **【SELECT +】** or **【SELECT -】** and make the change by **【+】** or **【-】**

Parameter Setting page

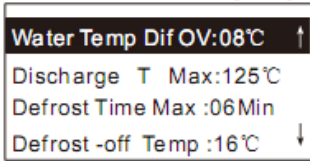

(Figure17)

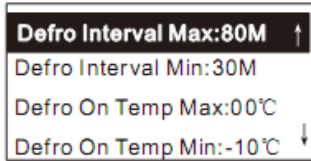

(Figure18)

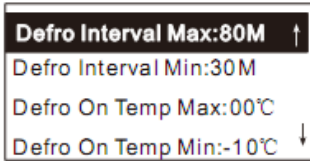

(Figure19)

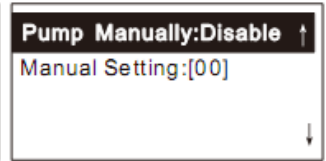

(Figure20)

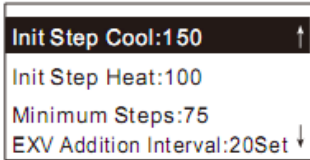

(Figure21)

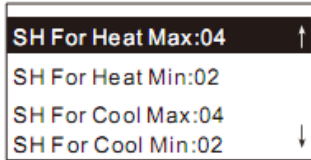

(Figure22)

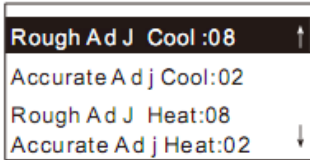

(Figure23)

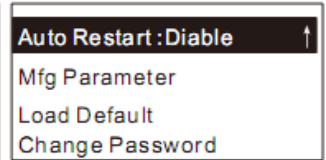

(Figure24)

9.Load Factory Settings

Enter the page as shown in Figure 24 by following the procedure in Parameter Setting, choose “Load Default” and press OK to load the default settings made in the factory.

10.Change Password

Enter the page as shown in Figure 24 by following the procedure in Parameter Setting, choose “Change Password” and press **【OK】** to enter the “Change Password” page (the display is the same as Password Entering) and enter a new password. The password is then successively changed(note: The password changed by the user can be reset to the default value of “1234” through “Load Default”).

11.Factory Parameter Setting

Enter the page as shown in Figure 24 by following the procedure in Parameter Setting, choose “Mfg Parameter” and press **【OK】** to enter the Enter page (Figure 16). After the password is correctly entered(the password entering method is the same as in “8. Parameter Setting”),the Factory Parameter Setting page will be activated.

Factory Parameter Setting page

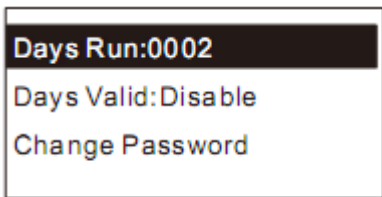

(Figure25)

Under the Factory Parameter Setting page, you may choose the item to change by pressing **【SELECT +】** or **【SELECT -】** and make the change by **【+】** or **【-】** .
If the use limit is activated and number of days in use > number of days limited, the system won't start up.

The Maintenance of the Chiller

Modular air cooled chiller (heat pump) is an equipment with high automaticity, whose operation condition should be checked regularly during its usage. If users can give the chiller a long-term and efficient maintenance, the reliability and lifetime of the chiller will be unexpectedly enhanced.

Daily operation

During daily operation, the power-on/off of the chiller can be automatically controlled by “Time Setting” function of the Wired Controller



Warning:

- In daily operation, after shutdown, the main power supply of the set mustn't be cut off. In case of power cut by accident, the set must be started up after preheated by electrified 8-hour, so as not to be damage.

Checking and Record of Operation of the Chiller

All the chillers have passed strict test and inspection before they go out, to ensure the chiller in good operation condition for a long time. Users should arrange maintenance and regular repair.

During the operation period, daily inspection and chart record on operation condition of the chiller is highly recommended. In reference to the chart below

Record on a week's operation condition of the chiller

Record	Date	03/06/12	04/06/12	05/06/12	06/06/12	07/06/12	08/06/12	09/06/12
Item		Sun	Mon	Tue	Wed	Thu	Fri	Sat
Voltage(V)								
Current(A)								
Power(kW)								
Run-time High pressure(Mpa)								
Run-time low pressure(Mpa)								
Pressure when chiller halt(Mpa)								
Return water temperature(°C)								
Outlet water temperature(°C)								
Vibration								
Noise								
Indoor temperature(°C)								
Outdoor temperature(°C)								
Others								
Notes								

Inspection and Cleaning of the chiller

Do not put groceries around the chiller, in case block the air inlet and outlet. Users should clean the fan filter of the indoor terminal regularly, keep clean and dry around the chiller, keep the chiller in good ventilation place, for maintaining good heat exchanging effect and saving energy.

To ensure the condenser works efficiently and exchanges maximum heat, the outside of the chiller must be cleaned regularly and kept from dirt which will make the condenser fin blocked like fallen leaves, cotton, insects and plastic bag. And regular cleaning of the fin is recommended.

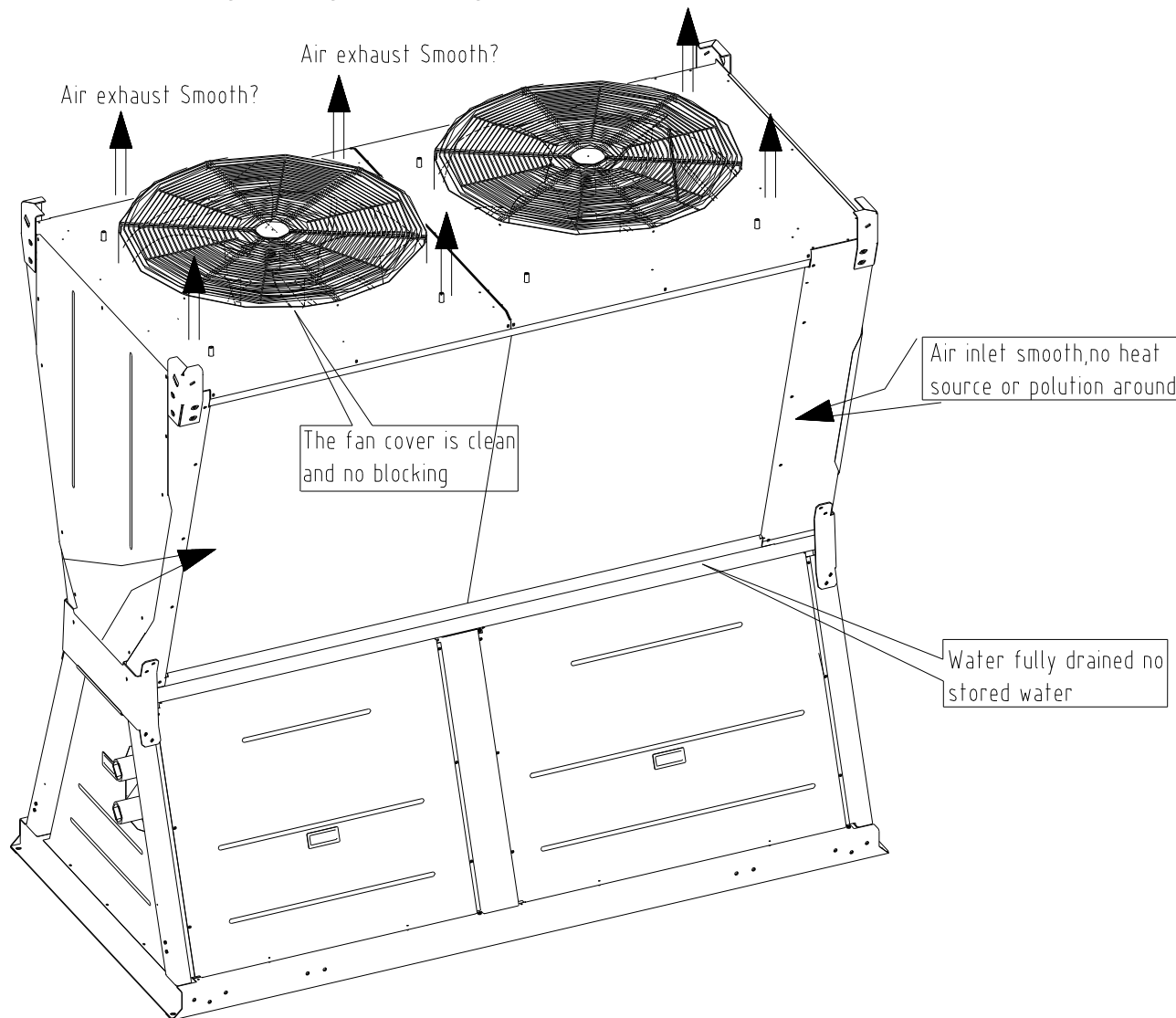

Inspection and Cleaning of chilled water

- ◇ Underground water, hard water or other sewage cannot be used as circulating water. Instead, users should use processed soft water as circulating water. (PH value is between 6.8 and 8)
- ◇ In using and maintaining the chiller, users should notice that all the safety protection devices inside the chiller have been set up before they go out of our factory, be sure not to adjust them by yourself.
- ◇ To check the water charging and exhaust equipment of the water system can avoid reducing the volume of water cycle or the failures of the water cycle which caused by the air coming into the system and impacts the cooling and heating effect and the reliability of the chiller.
- ◇ Generally, the filter installed in the return pipe can eliminate the impurity in water. The bean sizes of filter can filtrate different sizes of impurity. The 60 bean size filter is recommended. The bean size of filter is bigger, the capacity and limits are more extended, while the existing resistance will also be expanded much more, so it is necessary to be paid attention to clean the water filter and renew the filter screen at regular intervals. If the water replenishing pipe has been fixed, please be sure to fix a water treatment facility and a water filter. For the impurity is mainly made by the initial filling or pipe

fitting, the water used to clean the pipes must be clean and the water for initial cleaning must be draining, and before the starting up of the machine, the filter must be cleaned.

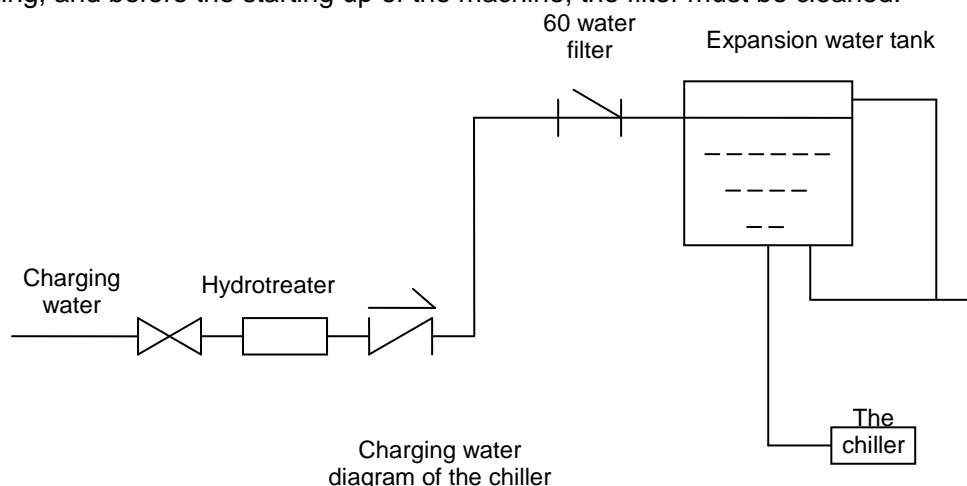

Electric Inspection and Maintenance

The failure types of the Air Conditioner System can be divided into electric circuit failure, refrigerant circuit failure, circulating water circuit failure and mechanical failure, etc. The electric circuit failure is common among these failure types, and the refrigerant circuit failure is hard to diagnose. This feature requires us to be meticulous in daily maintenance and inspection. Sum up experience, make right diagnosis and take effective measures without delay if the chiller operates anomalously. Follow the tips below to do troubleshooting:

1. Check and make sure the specification of all the power line meets the requirements, for example, is the sectional area of the power line big enough, and do the earth wire and the zero line meet the design requirements, etc.
2. Check and make sure the size and specification of the electric control component meets the design requirements and is working normally, like the specification of air switcher, fuse wire, contactor and protector, etc.
3. Check and make sure all the joints connecting well and stable. Check and strengthen all the bolt joints irregularly.
4. Check and make sure all the indicate lights work normally.

Special Warning

- Power line capacity undersize or circuit poor contact will both cause failure even fire disaster.

Other Notices of Maintenance

- Check the reliability of the power and electric wiring of the chiller regularly. Check the stability of the electric spare parts, and repair or change the spare parts without delay if there is problem.
- Check the operation state of various spare parts of the chiller, and check whether the operation pressure of the cooling system is normal. Make sure there is no oil leakage at the pipe joint and air charging valve.
- The water system should be cleaned with clean agent at least once every half a year. Besides, The fin copper heat exchanger should be cleaned every 2 to 3 months to keep good cooling efficiency and save energy.
- In winter, if the chiller won't operate for a long time, users should drain all the water from the chiller. If there is additional electric heating function, the water in the electric heating device should be drained and the power should be cut off. Users should recharge water into the system, exhaust air out of the system and do a overall inspection on the system and then use clean water to wash inside of the system before the next operation. If there is no problem with the previous steps, user can power on the chiller.
- The power of the chiller should not be cut off in winter operation, for avoiding water pipe and water side heat exchanger inside the chiller frozen and damaged.
- For expanding the lifetime of the chiller, do not keep the chiller in a frequent start-stop condition.





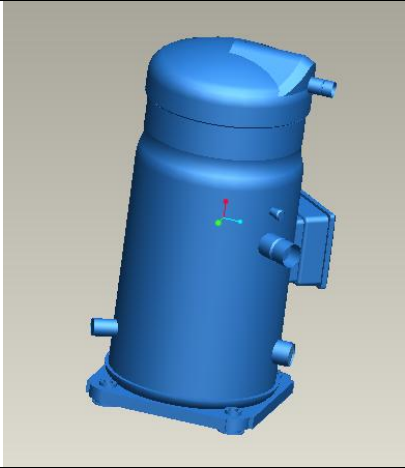
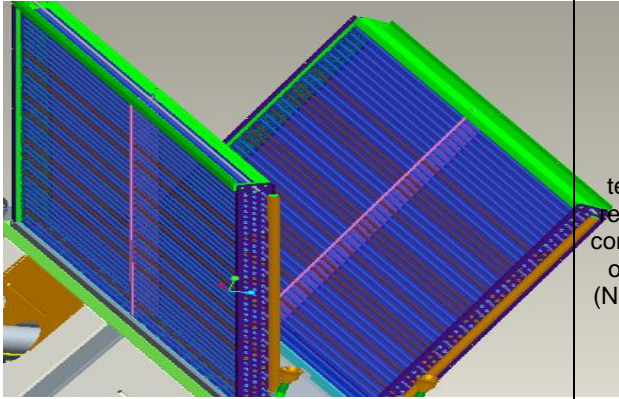
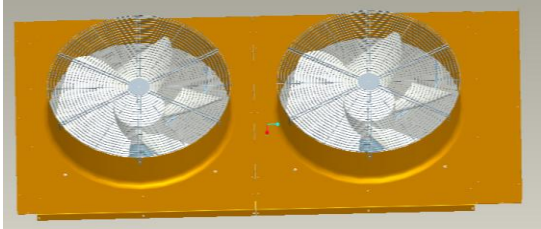
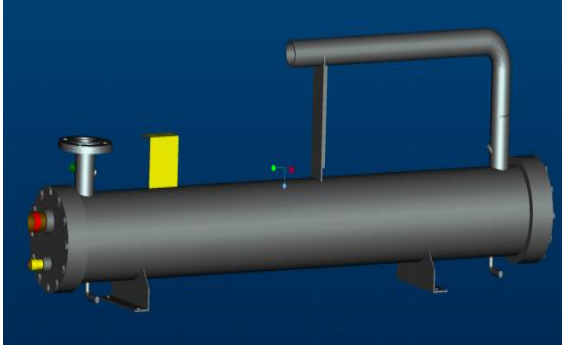

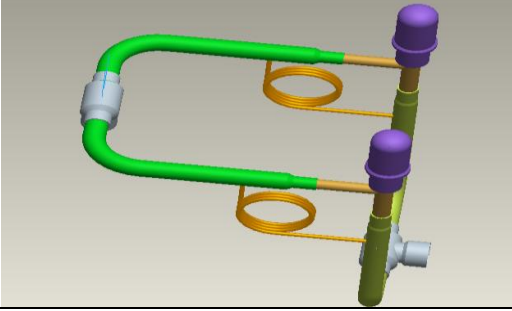
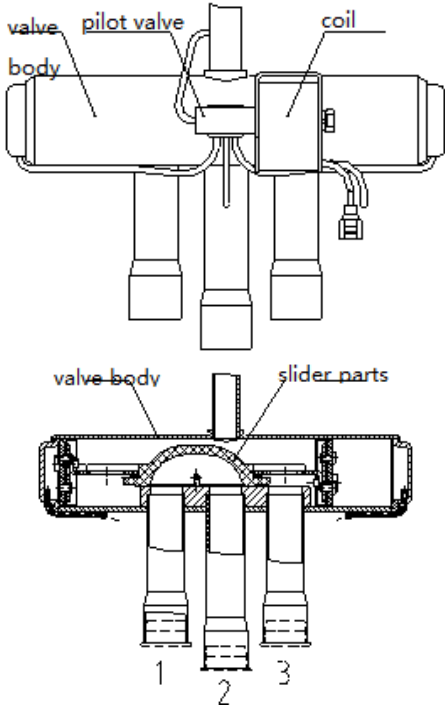
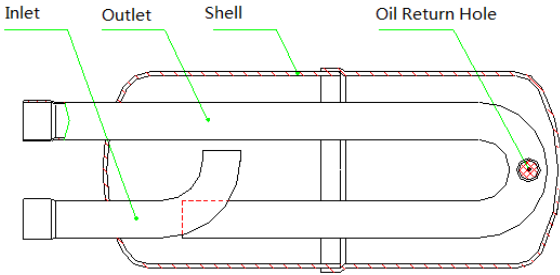
Part 4 After-sales

4.1 Main Spare Parts of the Chiller

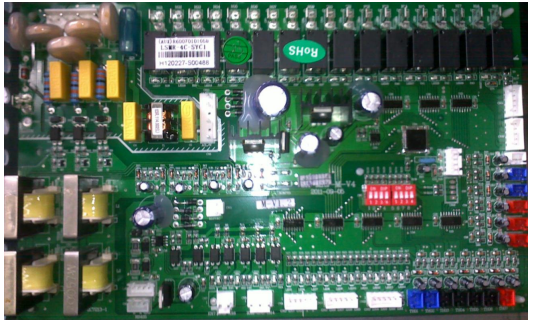
Name	Physical Dimension Picture and Internal Structure	Introduction
<p>Scroll compressor</p>		<p>The function of compressor: to compress the refrigerant gas which evaporated by evaporator from low temperature low pressure to high temperature high pressure and then sent it to the condenser to circulate the refrigerant. The series of products apply the fully-enclosed scroll compressor which is a collection of motor and compressor.</p>
<p>Condenser (heat exchanger)</p>		<p>The function of air cooled condenser: This is the heat exchanger which cool and condense(liquefy) the high temperature and high pressure refrigerant gas exhausted by the compressor by the heat exchange of the motor-driven fan and air. (Notes: when heating, it becomes the evaporator)</p>
<p>Components of centrifugal fan</p>		<p>Power machine spins the vane wheel and under the action of the centrifugal force the gas which between the vanes is threw from the center of vane wheel to the outer edge, then the gas inhaled by the finned condenser and the power machine gives the mechanical energy to the gas and the gas will the pressure energy and energy of motion.</p>
<p>Evaporator (shell-and-tube heat exchanger)</p>		<p>The function of evaporator: To make the low pressure liquid refrigerant which is from the capillary tube (expansion valve) heat exchanged evaporate with air in the evaporator.</p>

<p>Electronic expansion valve (throttling component)</p>		<p>computer program control throttling, the regulating range of refrigerant flow is larger and the control accuracy is higher.</p>
<p>four-way directional control valve</p>		<p>The function of four-way directional control valve: switching over flow direction of the refrigerant when the heat pump is making heating. It is used for for the heat pump air-conditioning set. The solenoid valve gets the electricity, when it is heating (not get electricity in cooling state),The slider parts move to right to make the pipe 2 and pipe 3 connected and then to switch over the direct of the refrigerant.</p>
<p>gas-liquid separator</p>		<p>The function of gas-liquid separator: Separate gas refrigerant and liquid refrigerant to protect the compressor from liquid strike</p>

4.2 Main Spare Parts of the Electric System

Name of Main Spare Parts	Physical dimension picture, internal structural picture	Introduction
PCB		<p>Hummmization control interface, easy and safe to operate; with self-diagnose, auto protect and alarm, for easy inquiry and troubleshooting; with long distance control function, can cooperate with BAS by RS485 communication protocol physical port</p>
fan motor		<p>Function of the fan motor: Drive the fan, and make the heat exchangers of indoor units and outdoor units exchange heat with air</p>
pressure switcher		<p>function of the pressure switcher Control the pressure inside the system, make sure the air conditioner cooling system in safe pressure range all the time</p>
operation capacitance		<p>Make single-phase motor generate rotating magnetic field, connecting with auxiliary coil and operate. So normal use durable one, specific brand</p>
AC contactor		<p>When the magnet coil of the contactor doesn't electrify, the main contact will be disconnected by the effect of the reaction of the compressed spring and the gravity of armature core. Once it is electrified, the electromagnetic force will overcome the reaction of the spring, the armature will be attracted to the static steel core and after the main contact closed, the circuit closed, auxiliary contact will follow its motion.</p>
sensor		<p>The physical property id changed with the temperature and pressure (as the NTC resistance is changed with temperature), an electrical component for the use of temperature and pressure detection.</p>

4.3 Function and Control of the Chiller

● Main function

◇ Operation Mode Selection

Operation mode of the system, heat pump type can choose these mode: cooling, heating, heating+additional electrical heating

◇ Timing on/off function selection

Users can select 24 hours timing, weekly timing

◇ auto restart

Auto restart function: when electricity blackouts and recovers again, the system will return to the state before blackout. This function is optional, users can decide to set this function or not.

◇ long-distance power on/off

◇ System protection

1. cooling overload protection

essential conditions before entering cooling overload protection

① compressor operates

② temperature of middle parts of the coil $\geq 68^{\circ}\text{C}$

After entering cooling overload protection, the chiller unloaded, the water pump continues operating

essential conditions before exiting cooling overload protection

③ temperature of middle parts of the outside coil $\leq 55^{\circ}\text{C}$, the relative failure code disappeared

④ If all the compressors halt, then the cooling operation will recover after the power-off protection time.

2. cooling antifreezing protection

Essential conditions of cooling antifreezing protection

① compressor operates

② outlet water temperature $\leq 4^{\circ}\text{C}$

Entering cooling antifreezing protection, system failure and halt

The conditions of exiting cooling antifreezing protection.

① outlet water temperature $\geq 7^{\circ}\text{C}$, relevant failure code has disappeared

② Compressor has met downtime, resumes cooling.

3. Heating overheating protection

Essential conditions of the heating overheating protection

① compressor operates

② outlet water temperature $\geq 55^{\circ}\text{C}$

Entering the heating overheating protection, show the failure code, show relevant module number, system failure and halt.

The conditions of exiting heating overheating protection

① outlet water temperature $\leq 50^{\circ}\text{C}$, relevant failure code has disappeared

② if all the compressors had stopped, resume heating must after all the compressors have met the downtime.

4. water lack temperature difference protection

Essential conditions of water lack

① compressor operates

② Absolute value of the inlet and outlet water temperature difference \geq [water lack temperature difference setting] 8°C and lasts for 180s

show the failure code, show relevant module number, system failure and halt

The conditions of exiting the protection.

① Absolute value of the total inlet and outlet water temperature difference $<$ [water lack temperature difference setting] -2°C , relevant failure code has disappeared

② Compressor has met downtime, resumes normal working.

5. antifreezing protection in winter use

Essential conditions of antifreezing protection in winter use

- ① The air conditioning in the shutdown state.
 - ② The inlet temperature $< 5^{\circ}\text{C}$, enter the antifreezing protection in winter use, water circulating pump starts up.
 - ③ The inlet temperature $< 3^{\circ}\text{C}$, meets the compressor starting conditions, the compressor starts heating.
- Essential conditions of exiting antifreezing protection in winter use
- ④ Starting up the Air conditioning
 - ⑤ The inlet temperature $\geq 10^{\circ}\text{C}$, exit antifreezing protection in winter use.

6.compressor high frequent starts and stops protection

The operation time is no less than 360s, stop time is no less than 180s, except system failure and halt situation.

● Failure Protection

1. Water volume switcher protection

essential conditions before entering water flow switcher protection

- ① Operating normally or the circulating water pump operates more than 30s during its virgin operation.
- ② The water flow switcher is in OFF state
- ③ The water flow arrives 10s later than normal

The failure code will display at this time and display relative module No, the chiller will halt and the heating 4-way valve will shut too.

2.compressor high pressure protection

essential conditions before entering high pressure protection

- ① Action time on high voltage switch lasts for 3s

The failure code will display at this time and display relative module No, the chiller will halt.

The conditions of exiting protection:

- ① Resetting the high voltage switch.
- ② Compressor has met downtime and resumes normal working.

3.compressor low pressure protection

Essential conditions of entering compressor low pressure protection

- ① Action time on low-voltage switch lasts for 3s

The failure code will display at this time and display relative module No, the chiller will halt.

The conditions of exiting protection:

- ① Resetting the low voltage switch.
- ② Compressor has met downtime and resumes normal working

Notes:

Fixed two low-voltage switch at low tension, 0.25Mpa (used when cooling)and 0.05MPa(used when heating), 0.25 Mpa can offer a protection in cooling state. In heating state, the 0.25Mpa which will be shielded at the start of the compressor and after the defrosting exiting for 3 minutes will be shielded, instead, it will start up the 0.05Mpa pressure protection.

4.freezing point switcher protection

Essential conditions of entering freezing point switcher protection

- ① compressor operates
- ② Action time on freezing point switch lasts for 3s

The failure code will display at this time and display relative module No, the chiller will halt.

The conditions of exiting protection:

- ① Resetting freezing point switch
- ② Compressor has met downtime and resumes normal working

5.outdoor fan overload protection

Essential conditions of entering outdoor fan overload protection

- ① Action time on contactor lasts for 3s

The failure code will display at this time and display relative module No, the chiller will halt.

The conditions of exiting protection:

- ① Resetting the contactor
- ② Compressor has met downtime and resumes normal working

6.phase protection

Essential conditions of entering phase protection

The contactor of phase protection is disconnected.

The failure code will display at this time and display relative module No, the chiller will halt.

The conditions of exiting protection:

Resetting the contactor of phase protection

7.compressor overload protection

Essential conditions of entering compressor overload protection

- ① Action on protection switch

The failure code will display at this time and display relative module No, stop relative compressor.

The conditions of exiting protection:

- ① Resetting the protection switch
- ② Compressor has met downtime and resumes normal working

8.Four-way valve reverse protection

Essential conditions of entering 4-way valve reverse protection

- ① Compressor operates

- ② Cooling: Inlet temperature-Outlet temperature $<0^{\circ}\text{C}$, Heating: Outlet temperature-Inlet temperature $<0^{\circ}\text{C}$ and lasts for 180S

After entering 4-way valve reverse protection,the chiller will halt

The conditions of exiting protection:

- ① Compressor has met downtime and then resumes normal working

9.Exhausting overheating protection

Essential conditions of entering the exhausting overheating protection

- ① Compressor operates

- ② Exhausting temperature $\geq 125^{\circ}\text{C}$ and lasts for 10s

After entering exhausting overheating protection, stop relative compressor.

The conditions of exiting protection:

- ① Compressor must have met downtime and then resumes normal working
- ② Exhausting temperature has recovered, $T \leq 90^{\circ}\text{C}$

● Control Theory

◇Power-on with cooling mode

When the controller sends "power-on" order or the timing setting time meets, the chiller will power on according to the following steps, or the system will standby.

And compressor startup should meets the following requirements:

1. $T(\text{return water temperature}) \geq T(\text{Setting temperature}) + 2$
2. Compressor halt time $\geq 180\text{s}$

◇Load and unload Control during cooling operation

1. The default setting temperature in cooling mode is
2. When the compressor halt, the next start-up should meet this requirement: halt time $\geq 180\text{s}$
3. Suppose the compressor of the modular chiller is power on, in cooling mode, if the $T(\text{return water temperature}) \leq T(\text{Setting temperature}) + 2$, then the system will exit cooling mode and enter normal loading and unloading control.

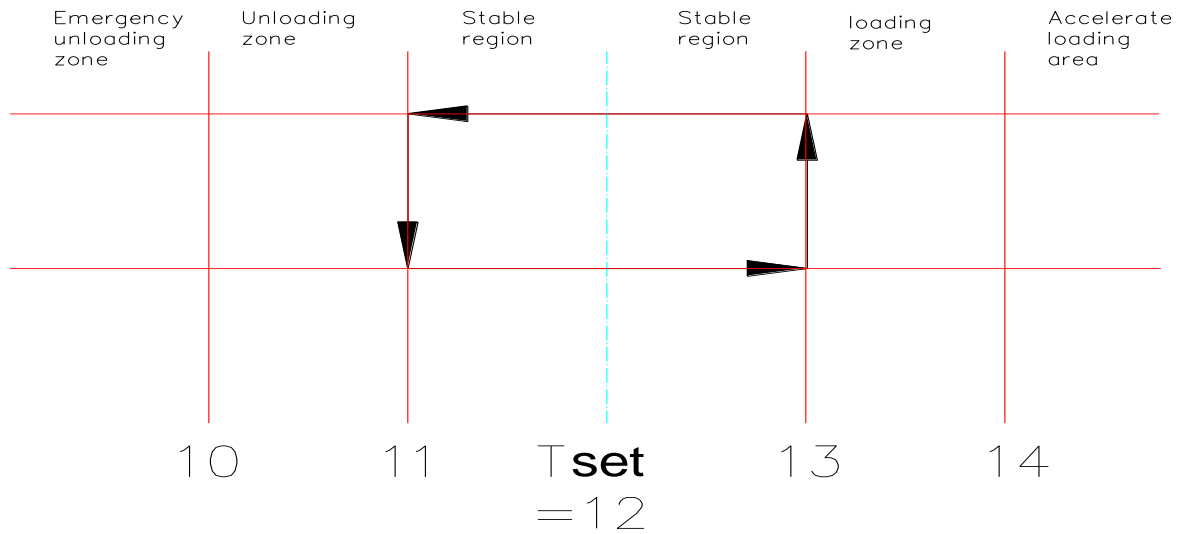

Heating Power

When the controller to issue the boot command, or in the regular starting time arrives, the unit processes in accordance with the following boot, or standby.

Compressor start subject to the following conditions

- 1. $T_{backwater} \leq T_{set} - 2$
- 2. Meet the compressor downtime $\geq 180s$;

The process of loading and unloading of heating system control

Parameters:

- 1. Heating mode initial set temperature $T_{set} = 40\text{ }^{\circ}\text{C}$,
- 2. Compressor shutdown, when meet the down time $\geq 180S$ can start again.
- 3. Heating mode $T_{backwater} \geq T_{set} - 2$ withdrawn from the heating start unloading into the normal control.

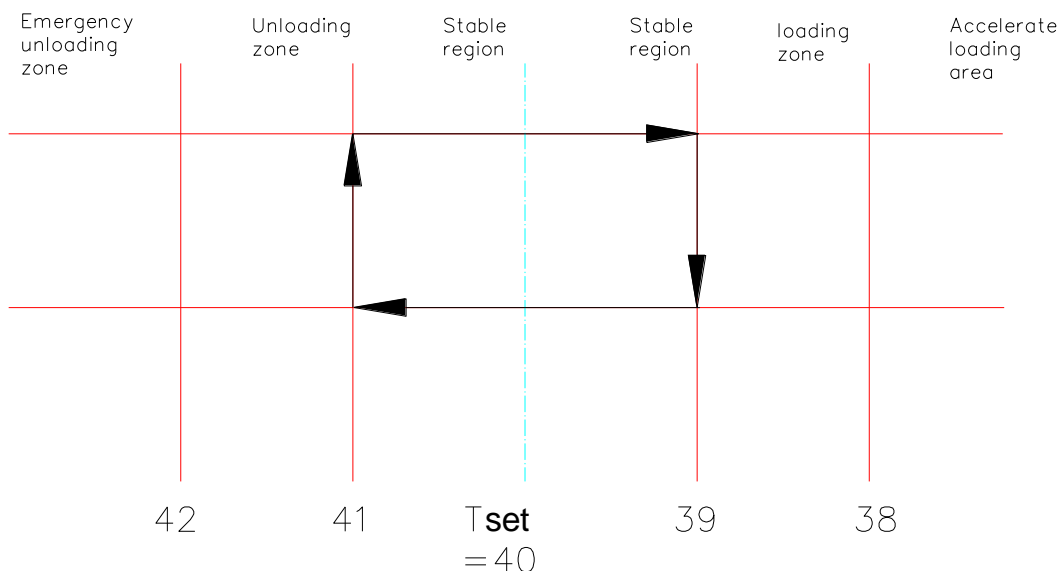

Unit loading and unloading control

Compressor start is according to each compressor run time to determine which one starts first, and which one starts later. It obeys the principle of “start first, then stop first” within 100h, when accumulated to 100h, the first to open the compressor which is running short. The same principles apply to the modules.

When all the compressors unloading stop, all the fans stop after the shutdown delay 10S.

Compressor loading and unloading time

1. Boot process: between the compressor 10 seconds, 60 seconds between modules.
2. Normal loading and unloading process: 60 seconds between the compressor, 60 seconds between modules.
3. Loading and unloading control after shutdown all compressors: 120 seconds between the compressor, 120 seconds between the modules.

Auxiliary electric heating control

Winter heat pump run-time use, refrigeration is not used.

1. All modules are put into operation, when the return water temperature to satisfy $T \leq$ 【heating return water temperature settings】 $-3\text{ }^{\circ}\text{C}$, auxiliary electric heating in operation.
2. When the return water temperature to meet the T backwater $>$ 【heating return water temperature settings】 $-1\text{ }^{\circ}\text{C}$, auxiliary electric heating decommissioning.

Spray valve control

Open precondition: 2 # fan in the run for 5 minutes to judge

- A. Cooling, depending on the central temperature of coil $T \geq$ 【Spray start temperature】 ($45\text{ }^{\circ}\text{C}$), then open, when T achieves at $35\text{ }^{\circ}\text{C}$, then off.
- B. Heating, the spray valve disconnect.

Control the oil temperature increases of tropical

Achieved by the strong electric, connect compressor turned down, disconnect when compressor turn off.

Return oil cycle control

When the single compressor cumulative operation time up to 2 hours, all the compressor unit up and running 3 minutes.

Defrost

If the unit performs a normal shutdown command, but the unit is defrosting time, the crews completed the first implementation of the defrosting process and then perform a normal shutdown.

If the bottom coil temperature sensor failures, the defrost interval to 40 minutes defrosting time is 3 minutes.

Single entry conditions of single unit frost:

- A. The settings for more than 360s operation time of the started compressor.
- B. When T central temperature of coil \leq 【defrost coil temperature】 the compressor run time continuing 2min.
- C. If the cumulative compressor run time exceeds the 【defrost interval】 settings, then to satisfy conditions to enter defrosting

Meet the above A, B, C conditions, the following procedure to enter defrosting.

The conditions of single unit out of defrosting:

If the conditions of frost from any of below can satisfy the exit

- A. When the defrost time \geq 5 minutes, the unit exit.
- B. When T central temperature of coil \geq 【 16°C 】 , the unit exit.

Electronic Expansion Valve Control

Electronic expansion valve reset when the unit standby: 1, increase the maximum number of steps +20 P; 2, the electronic expansion valve to the 『initial steps』 ;

Control mode

A fixed number of steps to realize manual operation and automatically adjusts the number of steps to run.

Manual steps to run a fixed, in any condition to run a fixed number of steps.

Automatically adjust the default number of steps to run for the first time (re) adjusts the default power.

Automatically adjust control

After the initial power, electronic expansion valve first zero (the maximum number of steps +50 p) operation, then reset to the initial step (【the refrigeration initial opening】 to set the value; 【heating the

initial opening】 for the set value) .

Automatically adjust cooling

When compressor runs, the minimum opening of the electronic expansion valve is [the minimum number steps of cooling to set 100P] (that is adjusted to 100, not to reduce the direction of adjustment), the largest opening is the 【maximum number of steps to set 480P】 (that is adjusted to 480, it will not adjust to the increasing direction).

- 1.Cooling operation, if all the compressor of corresponding system closed, the electronic expansion valve of the corresponding system opening to maintain the current value unchanged.
- 2.Compressor starts, the electronic expansion valve adjustment every 【interval time】 to adjust an electronic expansion valve opening, regulation is based on ΔT (T back gas-T cooling evaporator inlet temperature)

Temperature range	Adjusting direction	Adjusting range
$\Delta T < \text{【Refrigeration superheat limit】} -1^\circ\text{C}$	Reduced	Thick adjustable 【Refrigeration thick adjustable】 step
$\text{【Refrigeration superheat lower limit】} -1^\circ\text{C} \leq \Delta T < \text{【Refrigeration superheat lower limit】}$	Reduced	Fine tuning 【Refrigeration fine tuning】 step
$\text{【Refrigeration superheat lower limit】} \leq \Delta T \leq \text{【Refrigeration superheat upper limit】}$	keep	
$\text{【Refrigeration superheat upper limit】} < \Delta T \leq \text{【Refrigeration superheat upper limit】} +1^\circ\text{C}$	Increase	Fine tuning 【Refrigeration fine tuning】 step
$\Delta T > \text{【Refrigeration superheat upper limit】} +1^\circ\text{C}$	Increase	Thick adjustable 【Refrigeration thick adjustable】 step

Loading and unloading process

Parallel system, when the second, third compressor starts, the electronic expansion valve opening to increase the original basis of 【the electronic expansion valve compensation 100 steps】 to set further steps, and stability of 1min.

Parallel system, when the first, second compressor unloading stops, the electronic expansion valve opening based on the original electronic expansion valve to reduce 【the electronic expansion valve compensation 100 steps】 to set steps and stability 1min.

Automatic adjustment of heating

When compressor runs, the minimum opening of the electronic expansion valve is [the minimum number steps of heating to set 100P] (that is adjusted to 100, not to reduce the direction of adjustment), the largest opening is the 【maximum number of steps to set 480P】 (that is adjusted to 480, it will not adjust to the increasing direction).

- 1.Heating operation, if all the compressor of corresponding system closed, the electronic expansion valve of the corresponding system opening to maintain the current value unchanged.
- 2.Compressor starts, the electronic expansion valve adjustment every 【interval time】 to adjust an electronic expansion valve opening, regulation is based on ΔT (T back gas-T bottom coil temperature)

Temperature range	Adjusting direction	Adjusting range
$\Delta T < \text{【Heating superheat limit】} -1^\circ\text{C}$	Reduced	Thick adjustable 【Heating thick adjustable】 step
$\text{【Heating superheat lower limit】} -1^\circ\text{C} \leq \Delta T < \text{【Heating superheat lower limit】}$	Reduced	Fine tuning 【Heating fine tuning】 step
$\text{【Heating superheat lower limit】} \leq \Delta T \leq \text{【Heating superheat upper limit】}$	keep	
$\text{【Heating superheat upper limit】} < \Delta T \leq \text{【Heating superheat upper limit】} +1^\circ\text{C}$	Increase	Fine tuning 【Heating fine tuning】 step
$\Delta T > \text{【Heating superheat upper limit】} +1^\circ\text{C}$	Increase	Thick adjustable 【Heating thick adjustable】 step

3.Loading and unloading process

Parallel system, when the second, third compressor starts, the electronic expansion valve opening to increase the original basis of 【the electronic expansion valve compensation 100 steps】 to set further steps, and stability of 1min.

Parallel system, when the first, second compressor unloading stops, the electronic expansion valve opening based on the original electronic expansion valve to reduce 【the electronic expansion valve compensation 100 steps】 to set steps and stability 1min.

Exhaust Temperature Control

When the exhaust temperature is excessively high, the electronic expansion valve control access to protected status (in this case ignored the opening temperature control), control is as follows:

When the exhaust temperature $> 115\text{ }^{\circ}\text{C}$, the electronic expansion valve opening based on the original increase of 10 steps, cycle is 10S;

When the exhaust temperature $>105\text{ }^{\circ}\text{C}$, the electronic expansion valve opening based on the original increase of 10 steps, cycle is 20S;

When $90\text{ }^{\circ}\text{C} \leq$ the exhaust temperature $\leq 105\text{ }^{\circ}\text{C}$, the electronic expansion valve opening remains unchanged (no longer under an adjustment);

When the exhaust temperature $< 90\text{ }^{\circ}\text{C}$, electronic expansion valve opening returned to normal control.

Defrosting automatic adjustment

Into defrost, electronic expansion valve opening was increased to the maximum (increasing the maximum number of steps +50 P), stable 1min, and then carried out under refrigeration superheat adjustment.

Out of defrosting, electronic expansion valve reset to the initial steps of heating, adjust depend on the heating superheat after 2min stable operation.

Combination control module

1. The module unit boot: boot the main module unit boot first, separated by 1 minute from the module have switched; when the water temperature does not meet the conditions of the compressor start, start over.
2. the module unit off: from the module unit intervals between 1 minute off, and finally the implementation of off the main module (the main circulating pump module from the module after the closure of the compressor all the time delay off);
3. module loading and unloading: when many modules combination, loading and unloading control program with single module, namely the module as a unit control loading and unloading, loading sequence for 1 module 1 compressor, 2 compressor, 3 compressor, then 2 module 1 compressor, 2compressor, 3 compressor, then turn on, 1 module, after all the compressor finish loading ,in the above order to load corresponding 2 module compressors, uninstall also alexandrine, first open first stop between modules.
4. When the lord, secondary module combination, once the compressor is running, all the pumps of modules are required to open.
5. Module unit defrosting: if more than half of the module into defrost, then the module into the defrost interval time is 1 minute.

No	item	Unit	Setting range	The default value	Notes
1	Defrost tubes temperature	$^{\circ}\text{C}$	$-20\sim 0$	--	The default value is -6
2	Defrost interval	Min	20~120	--	The default value is 40
3	Refrigeration initial opening		50~500	150	
4	Heating initial opening		50~500	200	
5	Heating minimum step number setting		50~500	100	
6	Adjustment interval	S	5~100	20	
7	Refrigeration superheat upper limit	$^{\circ}\text{C}$	0~10	4	
8	Refrigeration superheat lower limit	$^{\circ}\text{C}$	0~10	2	

9	Heating superheat upper limit	°C	-6~10	2	
10	Heating superheat lower limit	°C	-6~10	0	
11	Refrigeration thick adjustable	step	0~10	8	
12	Refrigeration fine tuning	step	0~10	2	
13	Heating thick adjustable	step	0~10	8	
14	Heating fine tuning	step	0~10	2	
15	Heating return water temperature setting	°C	35~45	40	
16	Spray start temperature	°C	40~50	45	
17	Circulating Water Pump operation		A maximum run time of 4 hours	Manual effective once	(Water system drained)
18	Excessive temperature between inlet and outlet water	°C	5~15	8	
19	Each sensor temperature correction	°C	0~10	0	
20	Defrost tubes temperature lower limit	°C	-20~0	-20	Multiples of 1
21	Defrost tubes temperature upper limit	°C	-20~0	-0	Multiples of 1

Parameter Settings

Appendix I, the parameter setting table

Other settings

- 1, selection three compressors or double compressors through DIP switch: SW2-1 OFF for the double compressor, SW2-1 ON for three compressors.
2. Module Address can be selected through DIP switch SW1:
Can set the range 0-F (that is, addresses 1-16), 0 addresses is the main module, and the other is the secondary module.
- 3, cooling and heating share a point of low-voltage protection.

Part 5 Troubleshooting

5.1 Unit fault code table

Fault type	Action		Fault code	Fault code
	Main unit	Secondary unit		
Flow switch malfunction	Stop all the modules compressor	Stop the corresponding modules compressor	E01	Maintenance and Reset
1 # fan overload protection	Stop the corresponding module compressors	Stop the corresponding module compressors	E03	Maintenance and Reset
2 # fan overload protection	Stop the corresponding module compressors	Stop the corresponding module compressors	E04	Maintenance and Reset
Three-phase AC input phase lost or phase sequence protection	Stop the corresponding module, can't start up	Stop the corresponding module, can't start up	E05	Maintenance and Reset
Return water temperature sensor fault	Stop all the modules	Display the fault code, using master module return temperature to protect	E07	Repair or replacement
Water outlet temperature sensor fault	Stop the corresponding module compressors	Stop the corresponding module compressors	E08	Repair or replacement
Ambient temperature protection	Cancel the protection function	Cancel the protection function	E09	Repair or replacement
Protection against over-temperature heating	Stop the corresponding module compressors	Stop the corresponding module compressors	E12	Maintenance and Reset
protection of water flow shortage	Stop the corresponding module compressors	Stop the corresponding module compressors	E13	Maintenance and Reset
The wired remote control communication failure	Stop all the modules	Stop all the modules	E15	Maintenance and Reset
1 #High pressure switch protection	Stop the corresponding module compressors	Stop the corresponding module compressors	E18	Maintenance and Reset
2 #High pressure switch protection	Stop the corresponding module compressors	Stop the corresponding module compressors	E19	Maintenance and Reset
1 # Low pressure switch protection	Stop the corresponding module compressors	Stop the corresponding module compressors	E22	Maintenance and Reset
2 # Low pressure switch protection	Stop the corresponding module compressors	Stop the corresponding module compressors	E23	Maintenance and Reset
1 # Exhaust Over temperature protection	Stop the corresponding module compressor, if the case occurs 3 consecutive times within 1 hour, the fault lock	Stop the corresponding module compressor, if the case occurs 3 consecutive times within 1 hour, the fault lock	E26	Maintenance and Reset
2 # Exhaust Over temperature protection	Stop the corresponding module compressor, if the case occurs 3 consecutive times within 1 hour, the fault lock	Stop the corresponding module compressor, if the case occurs 3 consecutive times within 1 hour, the fault lock	E27	Maintenance and Reset
Communication failures between modules	Reported failure to stop the corresponding module	Stop the corresponding module	E30	Maintenance and Reset
Cooling anti-freeze protection	Stop all the modules compressor	Stop all the modules compressor	E33	Maintenance and Reset
1 # compressor current protection	Stop the corresponding module compressors	Stop the corresponding module compressors	E34	Maintenance and Reset
2 # compressor current protection	Stop the corresponding module compressors	Stop the corresponding module compressors	E35	Maintenance and Reset

1 # exhaust temperature sensor failure	Stop the corresponding module compressor, if the case occurs 3 consecutive times within 1 hour, the fault lock	Stop the corresponding module compressor, if the case occurs 3 consecutive times within 1 hour, the fault lock	E42	Repair or replacement
2 # exhaust temperature sensor failure	Stop the corresponding module compressor, if the case occurs 3 consecutive times within 1 hour, the fault lock	Stop the corresponding module compressor, if the case occurs 3 consecutive times within 1 hour, the fault lock	E43	Repair or replacement
Module address repeat	Normal operation, indicating failure		E54	Maintenance and Reset
1 # coil bottom temperature sensor failure	Stop the corresponding module compressors in heating mode	Stop the corresponding module compressors in heating mode	E57	Repair or replacement
2 # coil bottom temperature sensor failure	Stop the corresponding module compressors in heating mode	Stop the corresponding module compressors in heating mode	E58	Repair or replacement
1 # return air temperature sensor fault	Stop the corresponding module compressors	Stop the corresponding module compressors	E59	Repair or replacement
2 # return air temperature sensor fault	Stop the corresponding module compressors	Stop the corresponding module compressors	E60	Repair or replacement
1 # evaporator temperature sensor failure	Stop the corresponding module compressors in cooling mode	Stop the corresponding module compressors in cooling mode	E61	Repair or replacement
2 # evaporator temperature sensor failure	Stop the corresponding module compressors in cooling mode	Stop the corresponding module compressors in cooling mode	E62	Repair or replacement
1 # Oil temperature sensor failure	Stop the corresponding module compressors	Stop the corresponding module compressors	E63	Repair or replacement
2 # Oil temperature sensor failure	Stop the corresponding module compressors	Stop the corresponding module compressors	E64	Repair or replacement
1 # oil temperature too low protection	Stop the corresponding module compressor, if the case occurs 3 consecutive times within 1 hour, the fault lock	Stop the corresponding module compressor, if the case occurs 3 consecutive times within 1 hour, the fault lock	E65	Maintenance and Reset
2 # oil temperature too low protection	Stop the corresponding module compressor, if the case occurs 3 consecutive times within 1 hour, the fault lock	Stop the corresponding module compressor, if the case occurs 3 consecutive times within 1 hour, the fault lock	E66	Maintenance and Reset
1 # antifreeze low pressure protection	Stop the corresponding module compressor, if the case occurs 3 consecutive times within 1 hour, the fault lock	Stop the corresponding module compressor, if the case occurs 3 consecutive times within 1 hour, the fault lock	E67	Maintenance and Reset
2# antifreeze low pressure protection	Stop the corresponding module compressor, if the case occurs 3 consecutive times within 1 hour, the fault lock	Stop the corresponding module compressor, if the case occurs 3 consecutive times within 1 hour, the fault lock	E68	Maintenance and Reset

5.2 Fault recovery Measures

Fault conditions	Possible reasons	Measures
Unit out of operation	Power supply failure	Disconnect the power switch and examine it
	Power supply cable loose	Find out reasons and repair
	Fuse of control power melt down	Replace with new fuse
Cooling capacity of unit lower; compressor not shut off	Insufficiency of refrigerant	Detect system leakage and re-charge refrigerant
	Deficiency of water system insulation	Strengthen system insulation
	Dry filter blocked	Replace the dry filter
	Deficiency of condenser heat exchanging	
	Insufficiency of water flow	Clean water filter
High pressure protection of compressor	Excess of refrigerant	Discharge the excess refrigerant
	Deficiency ventilation due to air inlet blocked	Remove the influential factors and improve condensing conditions
	Condenser dirty and blocked	Clean the condenser
Phase sequence protection	Power phase sequence reversed	Adjust the phase sequence
	Power phase lack	Check the power supply and ask the electrician to repair it
	Protector Damaged or circuit in connection open	Replace the anti-frost switch or reconnect the cables
Communication failure	Loose contact of communication cables	Check and reconnect them
	Short circuit or open circuit of communication cables	Check and reconnect them
	Wrong sequence of communications	Check and reconnect them
	Control panel or wire controller damaged	Replace the control panel or wire controller
High exhaust temperature protection	Leakage or insufficiency of refrigerant	Detect and repair the leakage dot
	Refrigerant system blocked	Examine and remove
	Changing value of exhaust air temperature sensor	Examine the sensor and replace it
	Setting aside the error code	Reset to dial the code
Water flow switch disconnection protection	Water pump out of operation	Examine the water pump and its control
	Excessive air in the water system	Discharge the air in the water system
	Water valve closed	Check and open the water valve
	Severe block of water filter	Examine and clean the filter
	Water flow switch damaged or circuit in connection open	Replace the water flow switch and reconnect the lines
Incompleted defrosting or no defrosting	Defrosting parameter setting not in accordance with local environment	Adjust defrosting parameter according to local climatic conditions
	Improper location of condensing temperature sensor	Adjust the location of condensing temperature sensor according to frosting status of unit
	Value changing of condensing or ambient temperature sensor	Detect and replace the sensor
Anti-frost switch protection	Low water temperature due to value changing of water inlet / outlet temperature sensor	Adjust defrosting parameter according to local climatic conditions

	Insufficiency of water flow	Adjust the location of condensing temperature sensor according to frosting status of unit
	Anti-frost switch damaged or circuit in connecting lines open	Detect and replace the sensor
Low suction pressure of compressor	Insufficiency of refrigerant or leakage	Leakage detection and re-charge refrigerant
	Block in dry filter	Replace the dry filter
	Insufficiency of water flow	Clean water filter or discharge the air in the system
	Break of capillary tube of temperature sensor package of expansion valve	Replace expansion valve
Compressor out of operation	Power supply failure	Find out reasons to solve the power supply failure
	Compressor contactor damaged	Replace contactor
	Connecting cables loose	Find out loosened point and repair
	Overheat protection of compressor	Restart the unit after find out the overheat reasons and solve the fault
	High outlet water temperature setting	Reset the outlet water temperature
	Insufficiency of water flow	Clean water filter or discharge the air in the system
High noise during compressor operation	Refrigerant of liquid state enter into the compressor	Check if the expansion valve disabled and if the temperature sensor package falls off
	Damaged components in the compressor	Replace compressor
Fan out of operation	Fan holding screws loose	Replace holding screws
	Fan motor damaged	Replace fan motor
	Contactors damaged	Replace contactor
Compressor operates, but no cooling (or heating) in the unit	Refrigerant leaked completely	Detect system leakage, repair and re-charge the refrigerant
	Compressor failure	Replace compressor
Low water temperature protection of the unit	Insufficient water flow in the system	Clean water filter or discharge the air in the system
	Low setting value on temperature controller	Reset it
Insufficient water flow protection of the unit	Air in the water system	Discharge the air in the water system
	Filter blocked in the water system	Clean filter in the water system
	Value changing of water inlet / outlet temperature sensor	Detect the resistance of the temperature sensor and replace.

5.3 Failure Analysis

(A) Communication failure

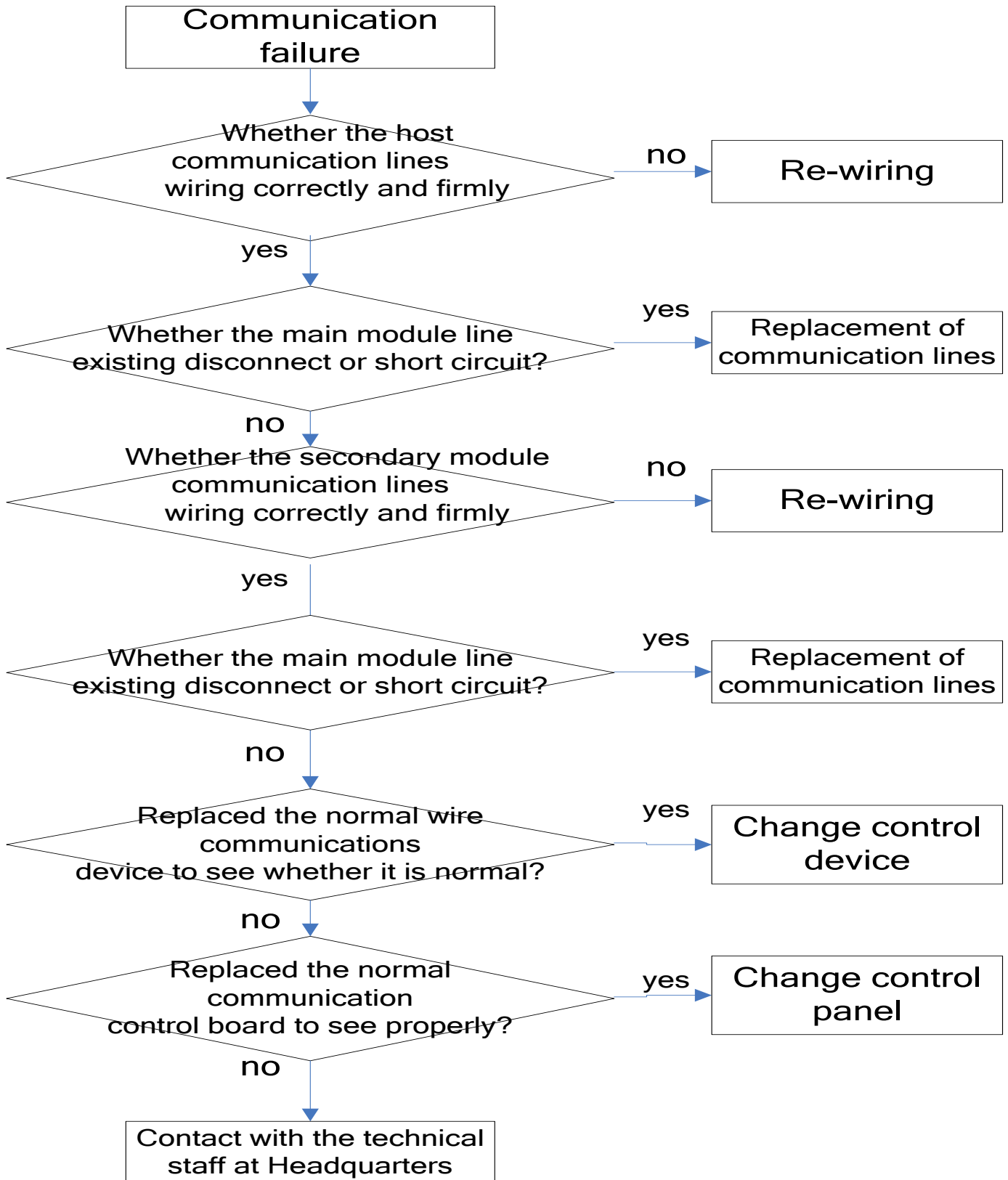

(B) Phase sequence protection

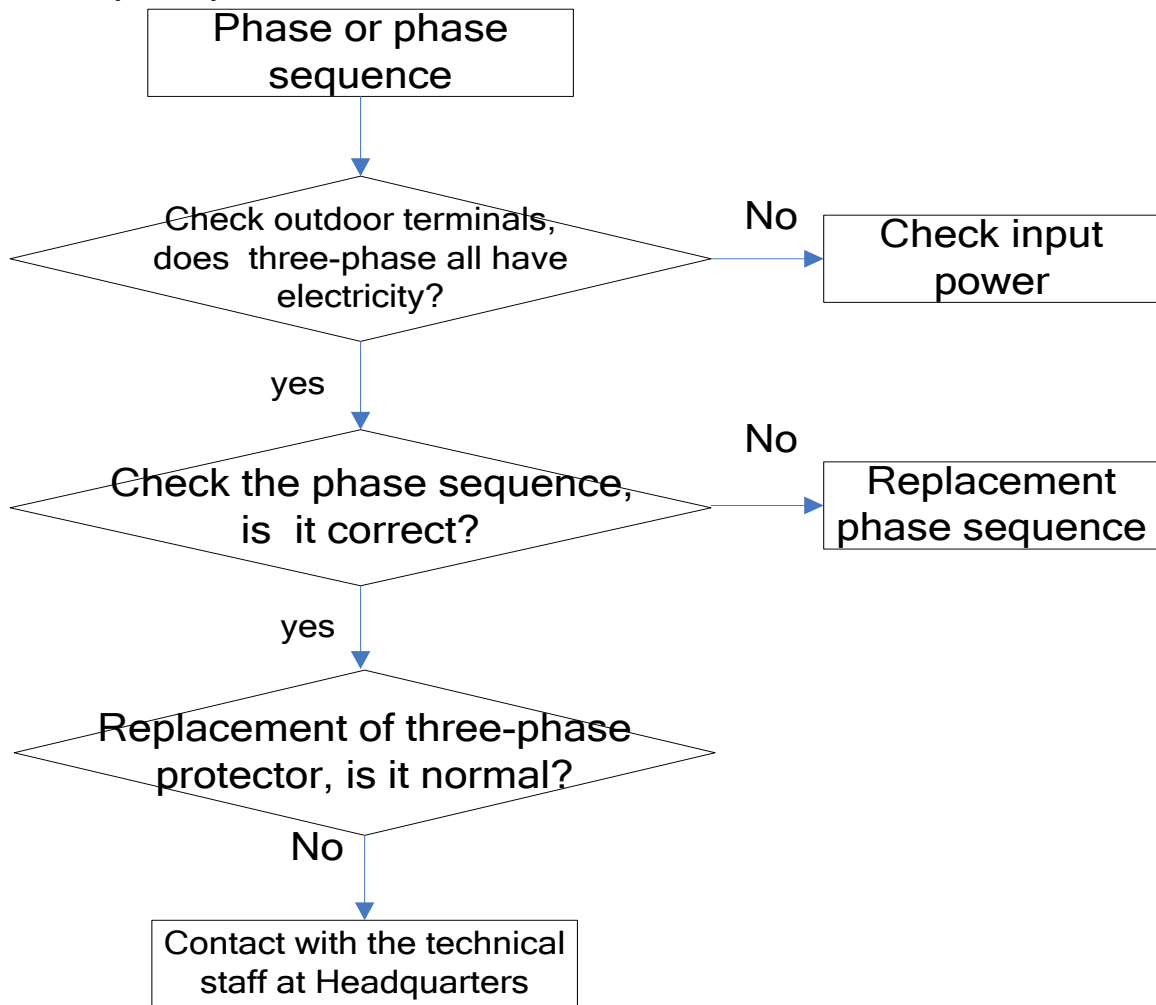

(C) Cooling high pressure protection

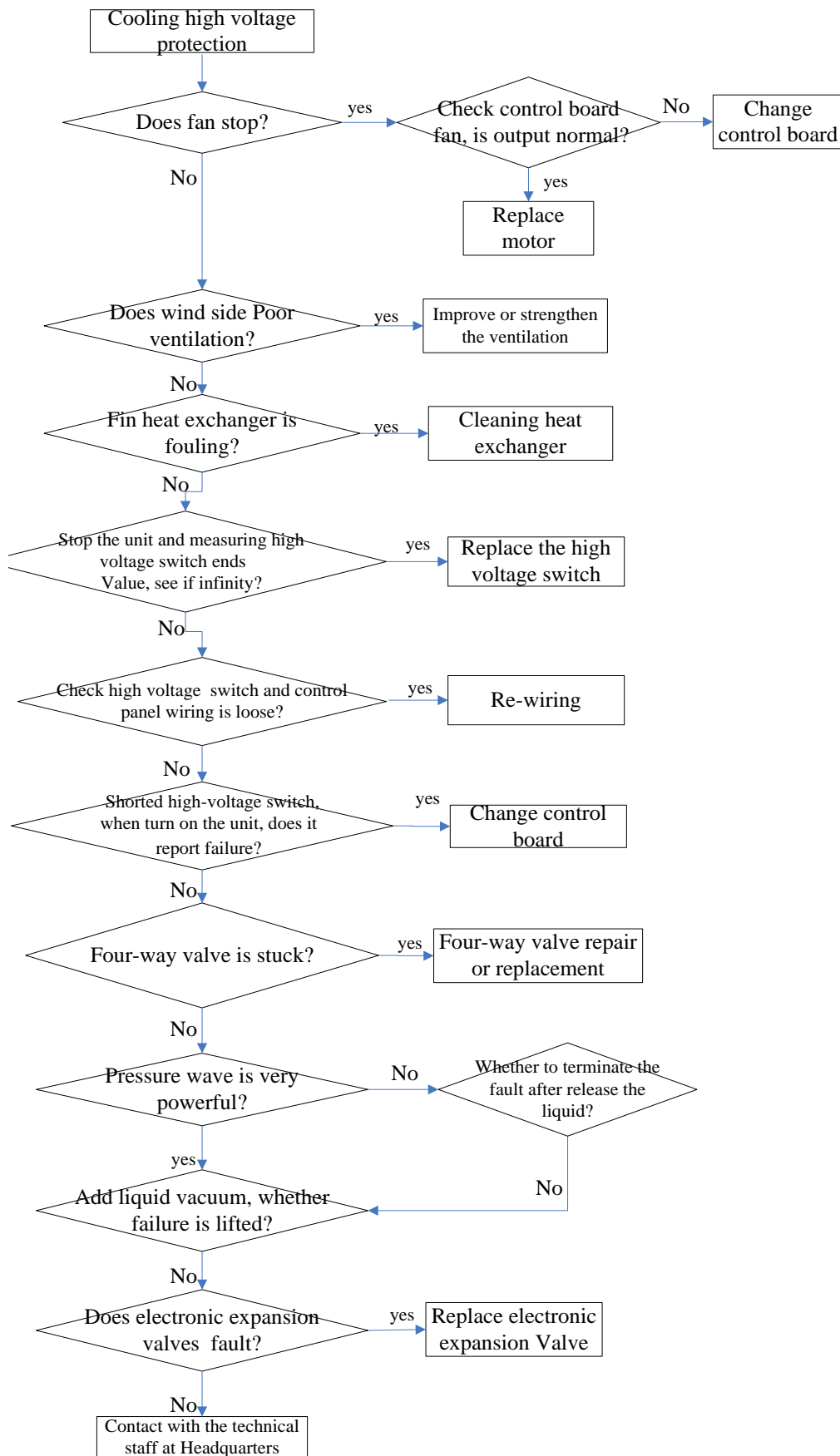

(D) Heating high pressure protection

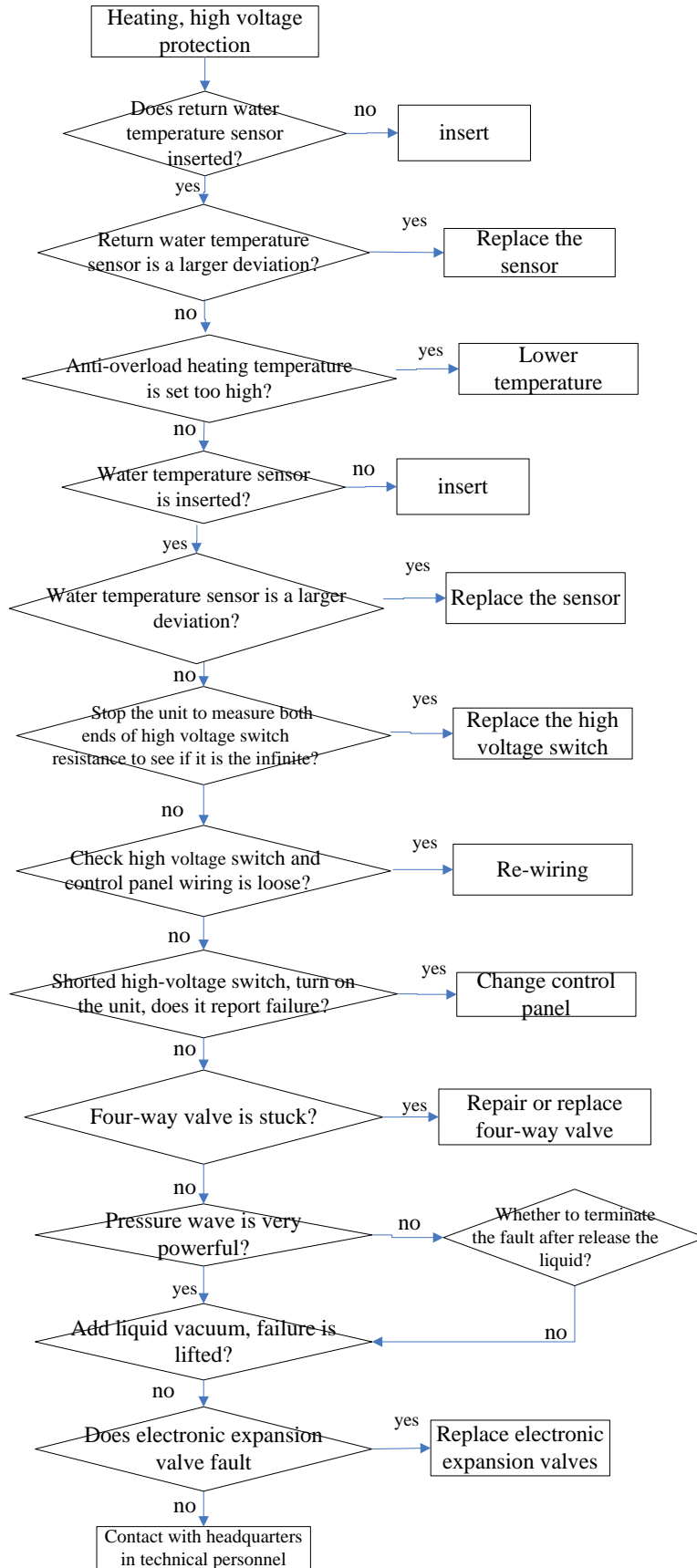

(E) Refrigeration low pressure protection

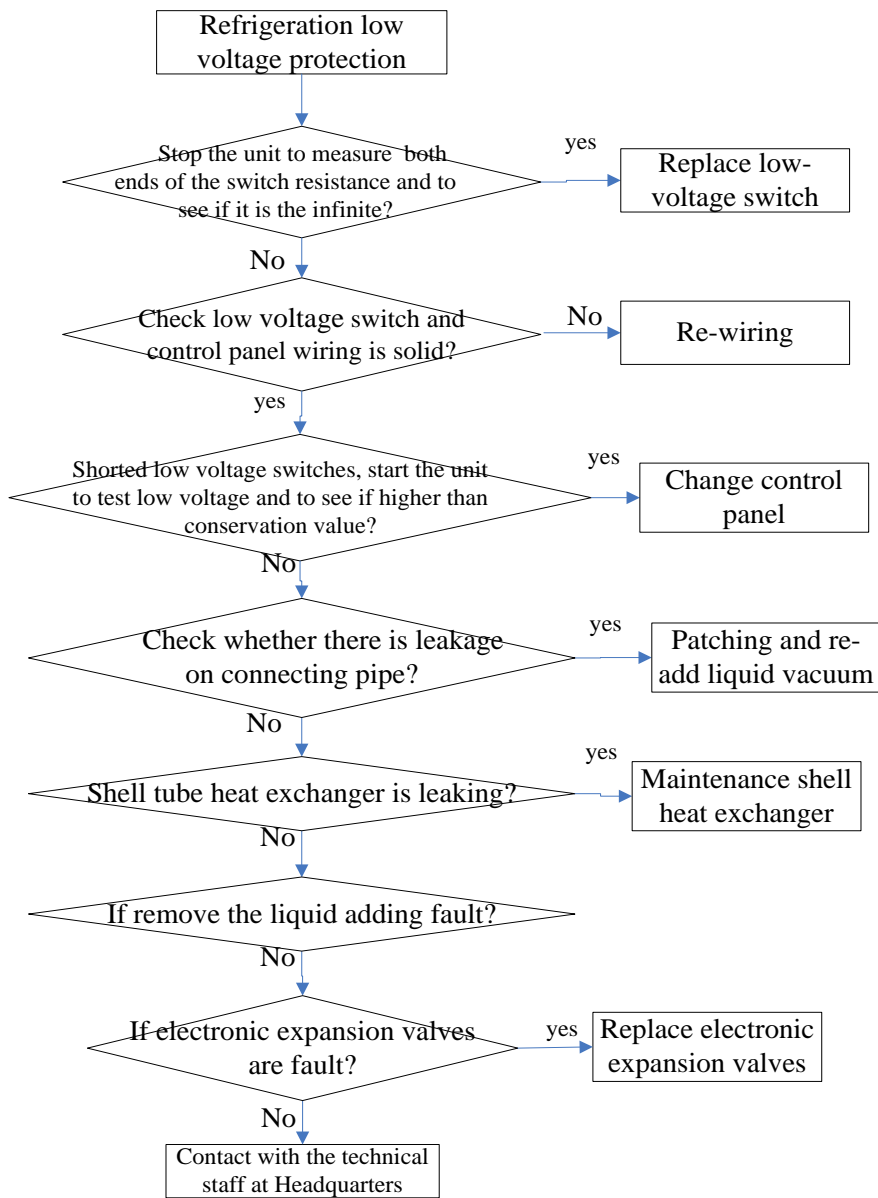

(F) Heating low pressure protection

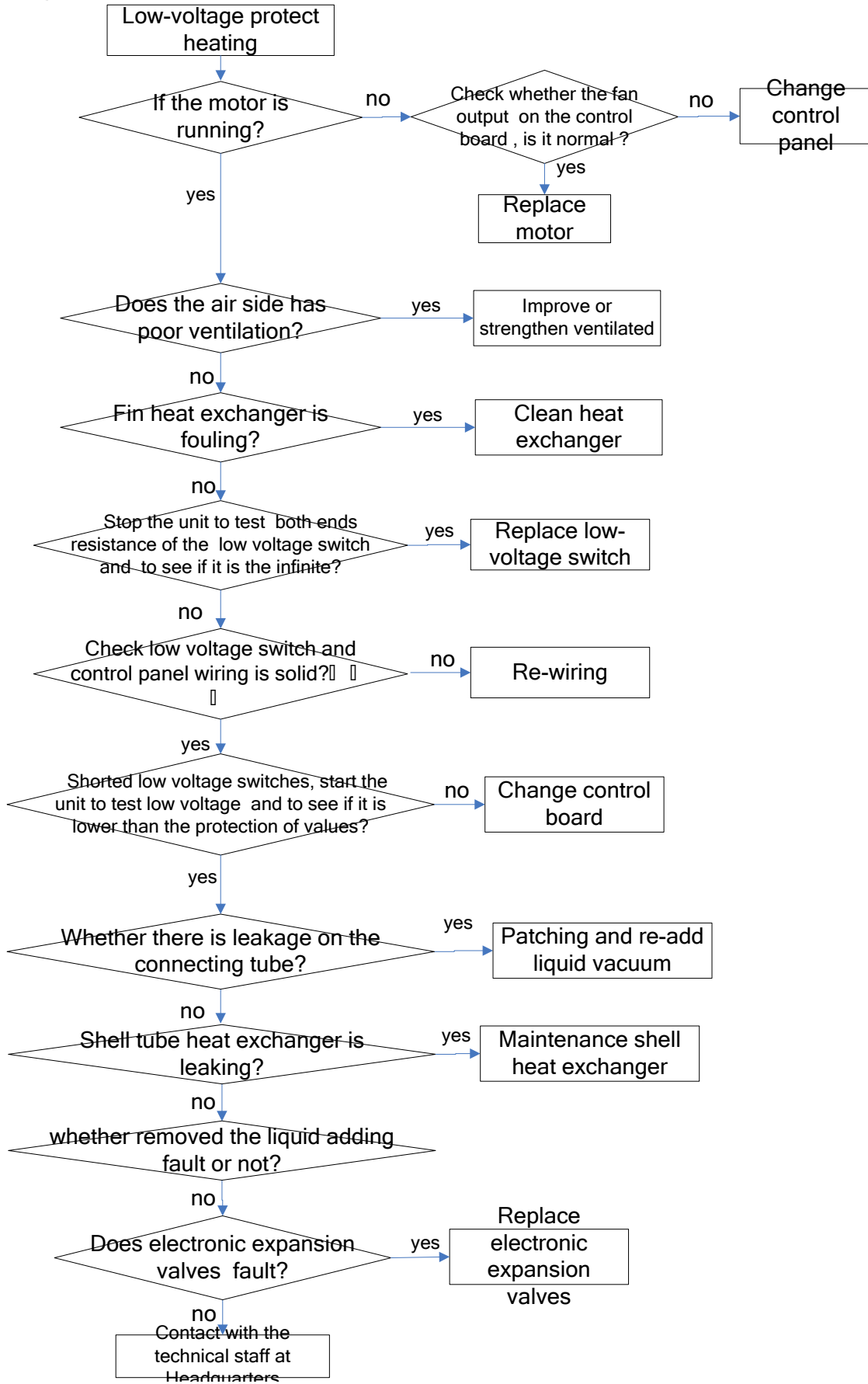

(G) Heating discharge temperature protection

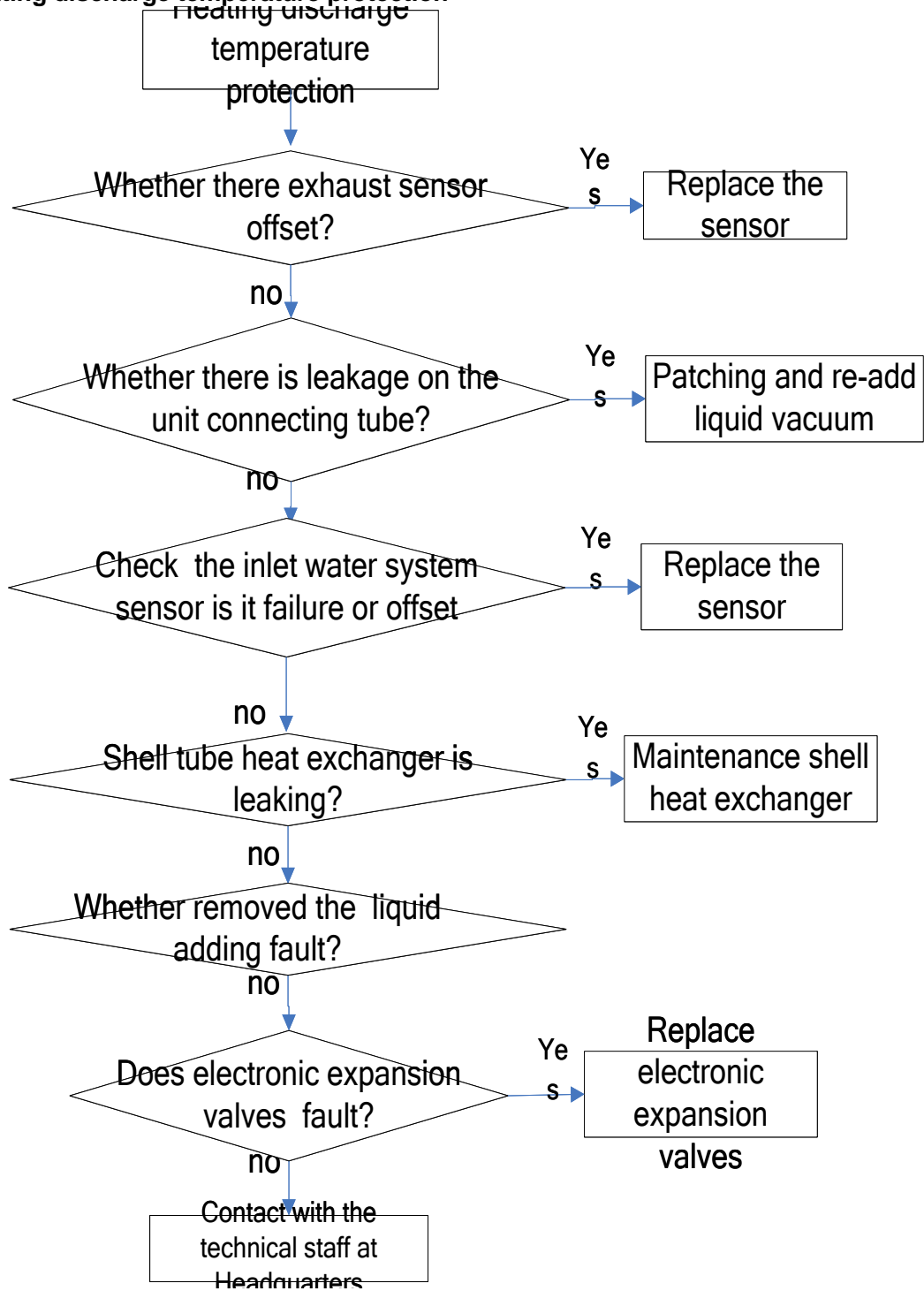

(H)Sensor Failure

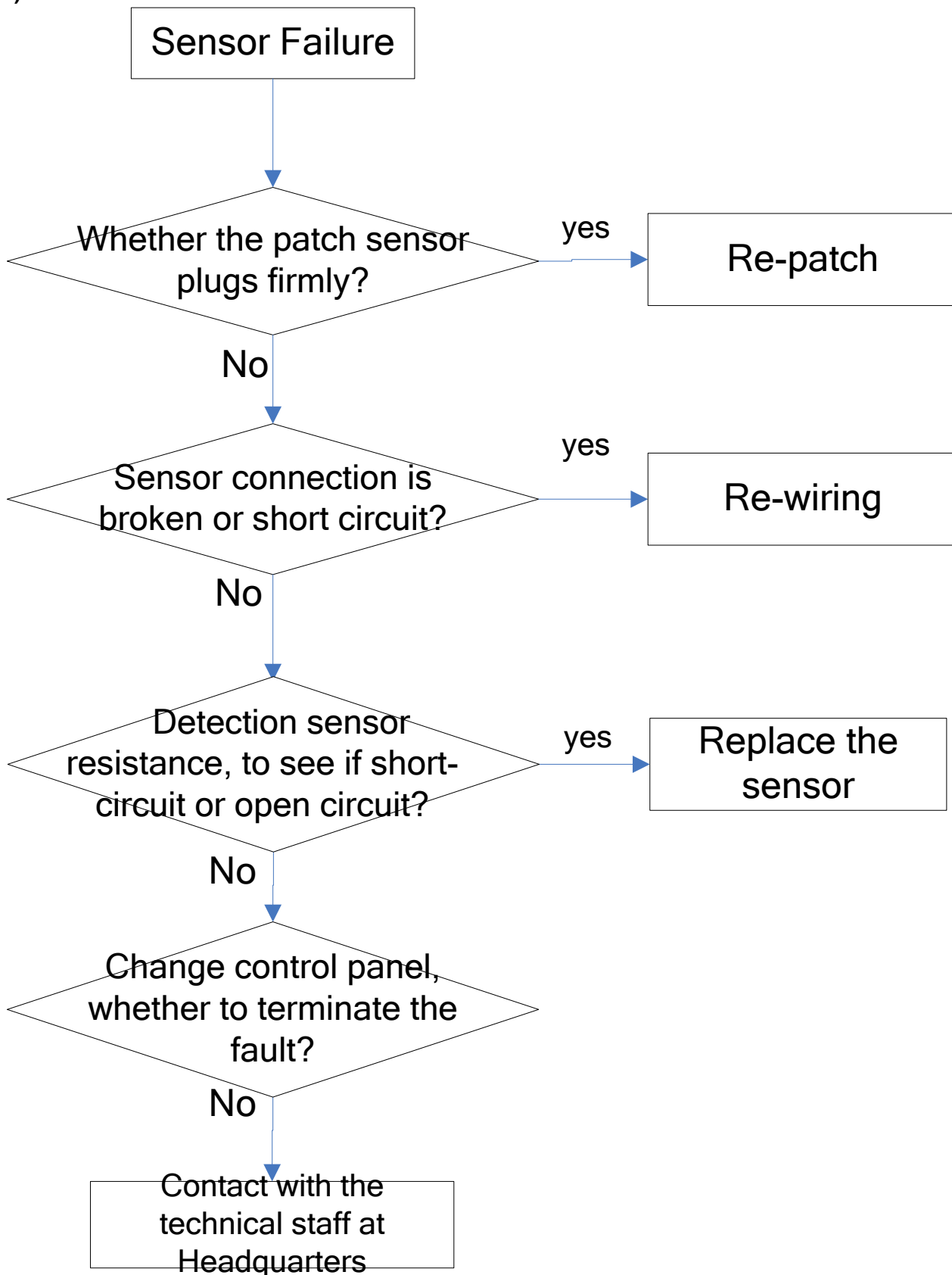

(I) Does not start after power on

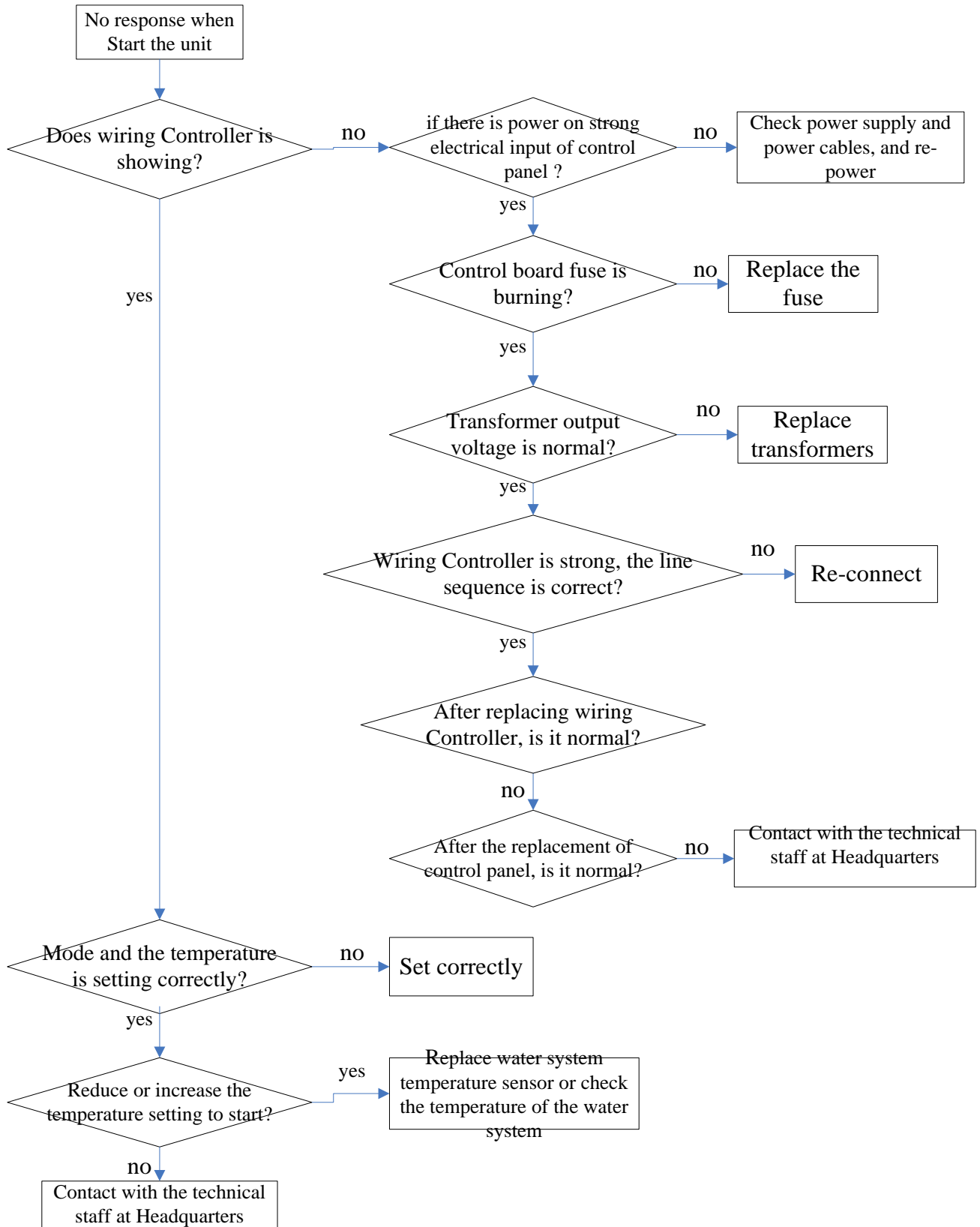

(J) After start to open the air switch jump

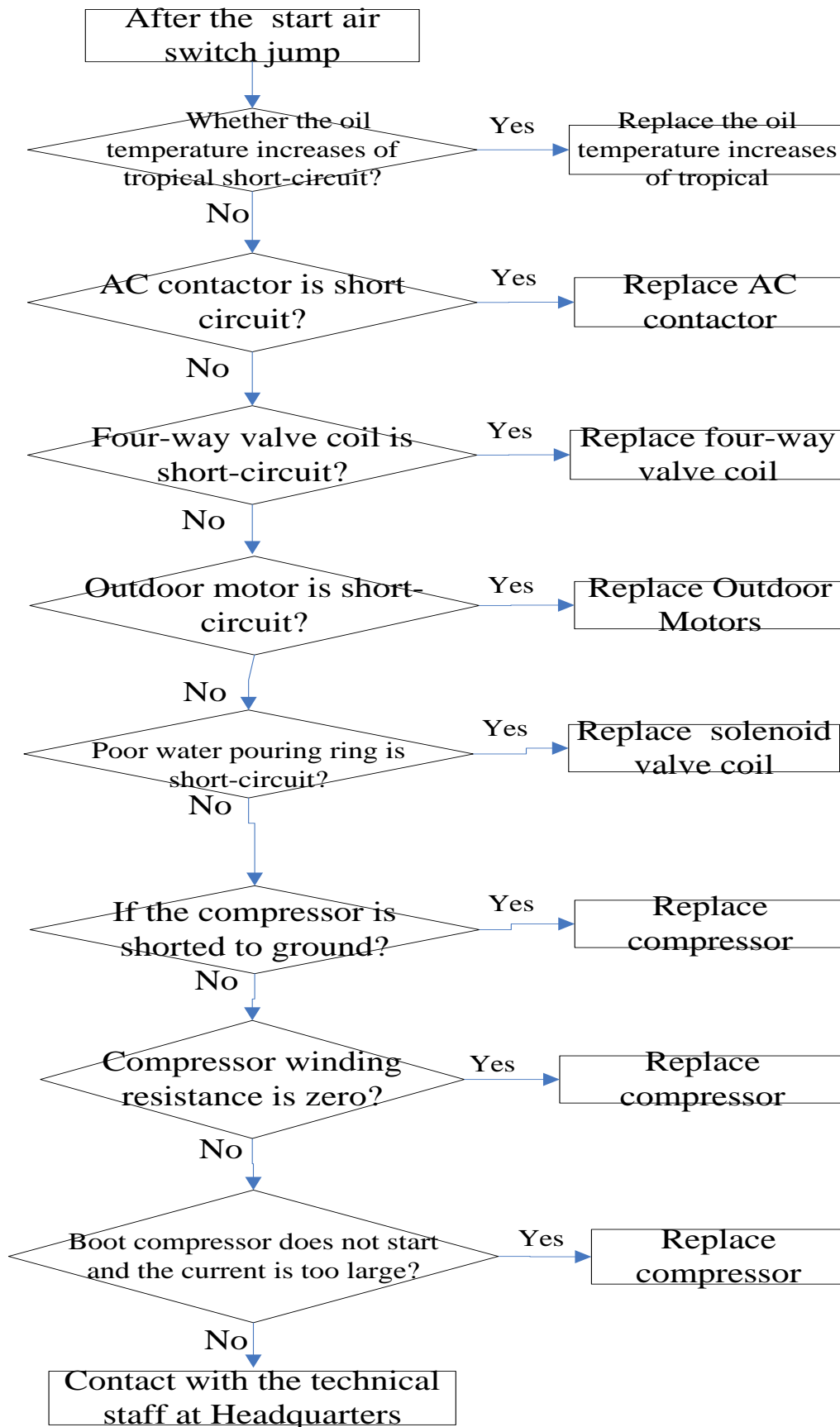

(K) Poor cooling and heating effects

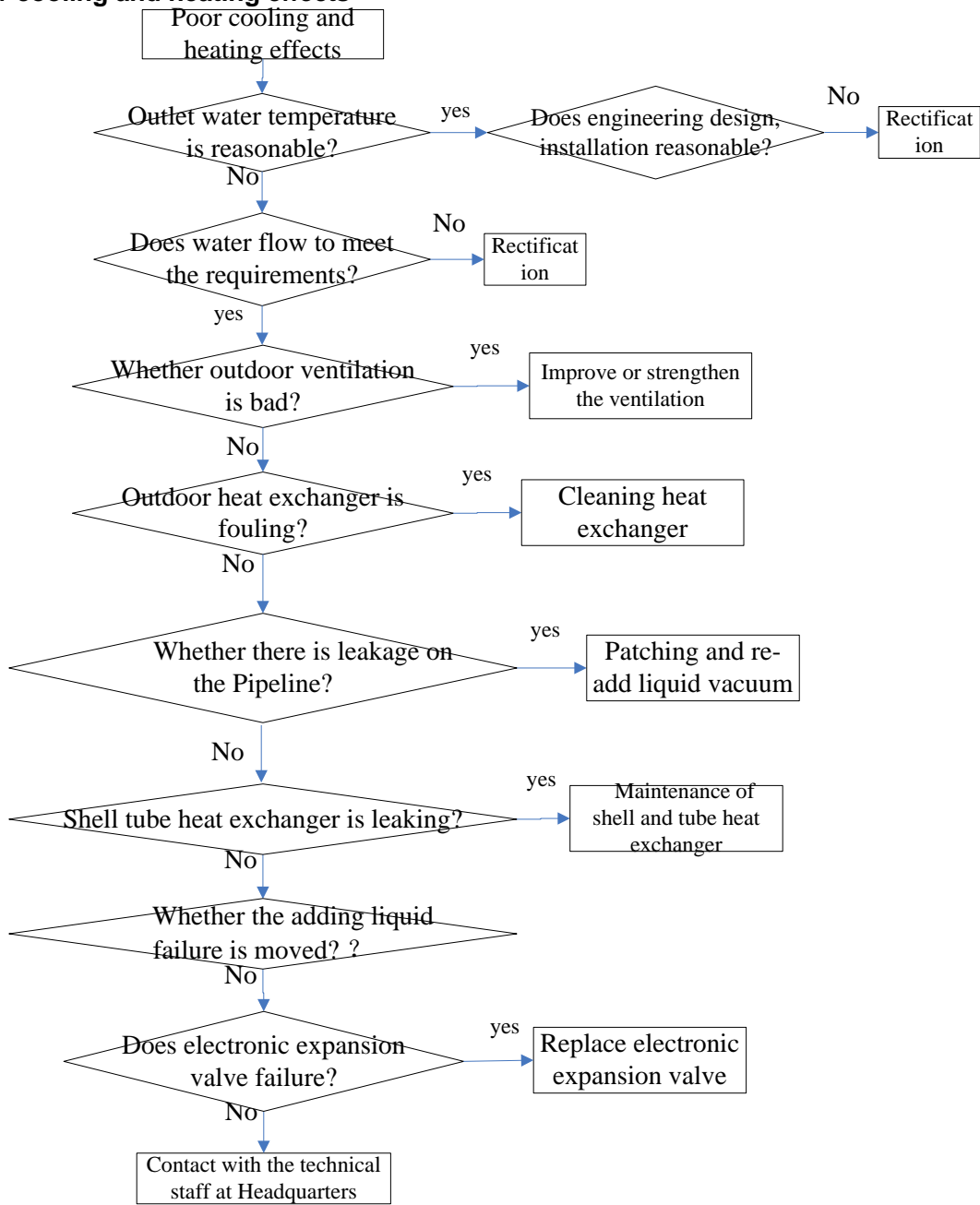

(L) Host abnormal sound

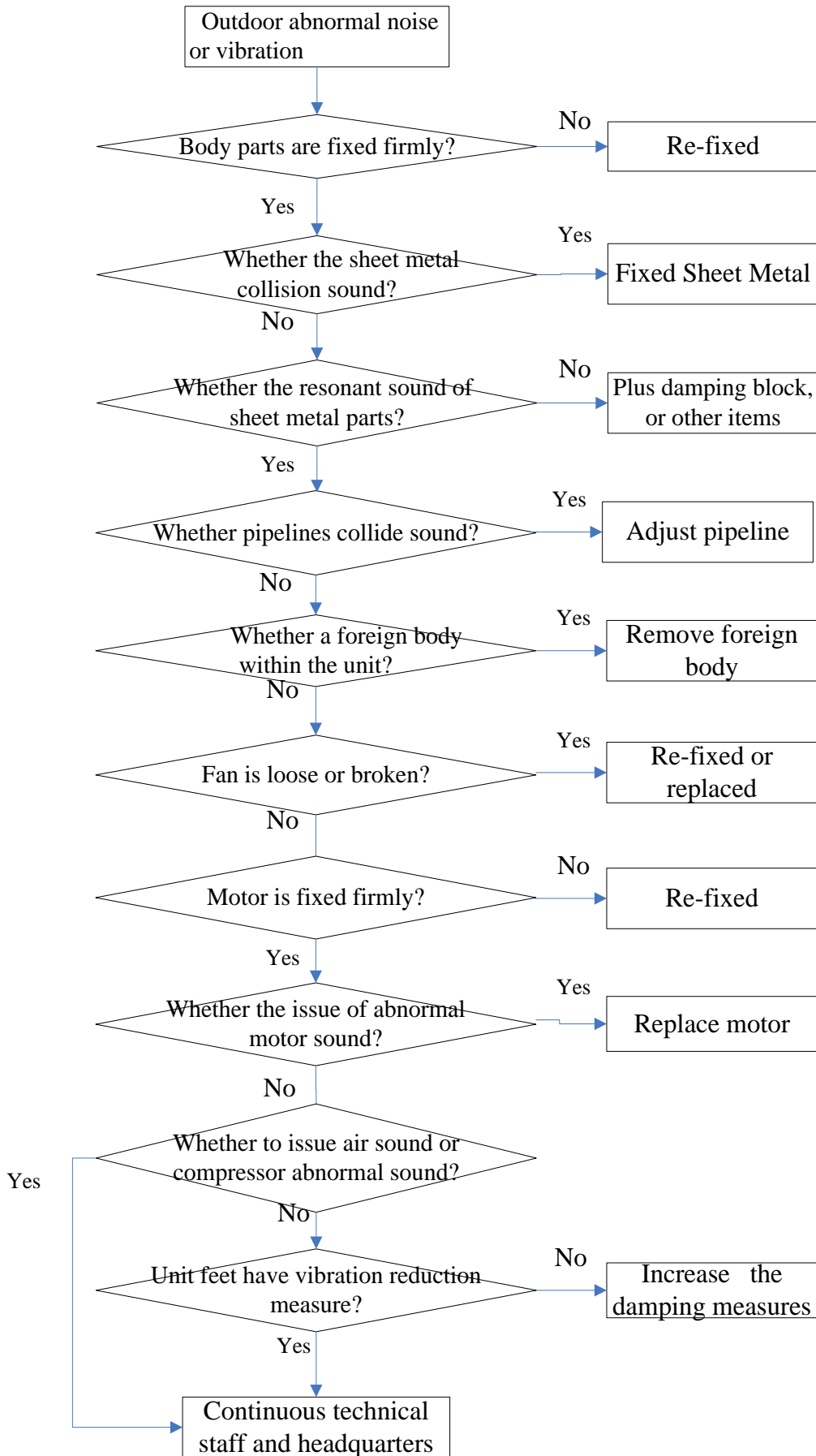

(M) Flow switch off protection

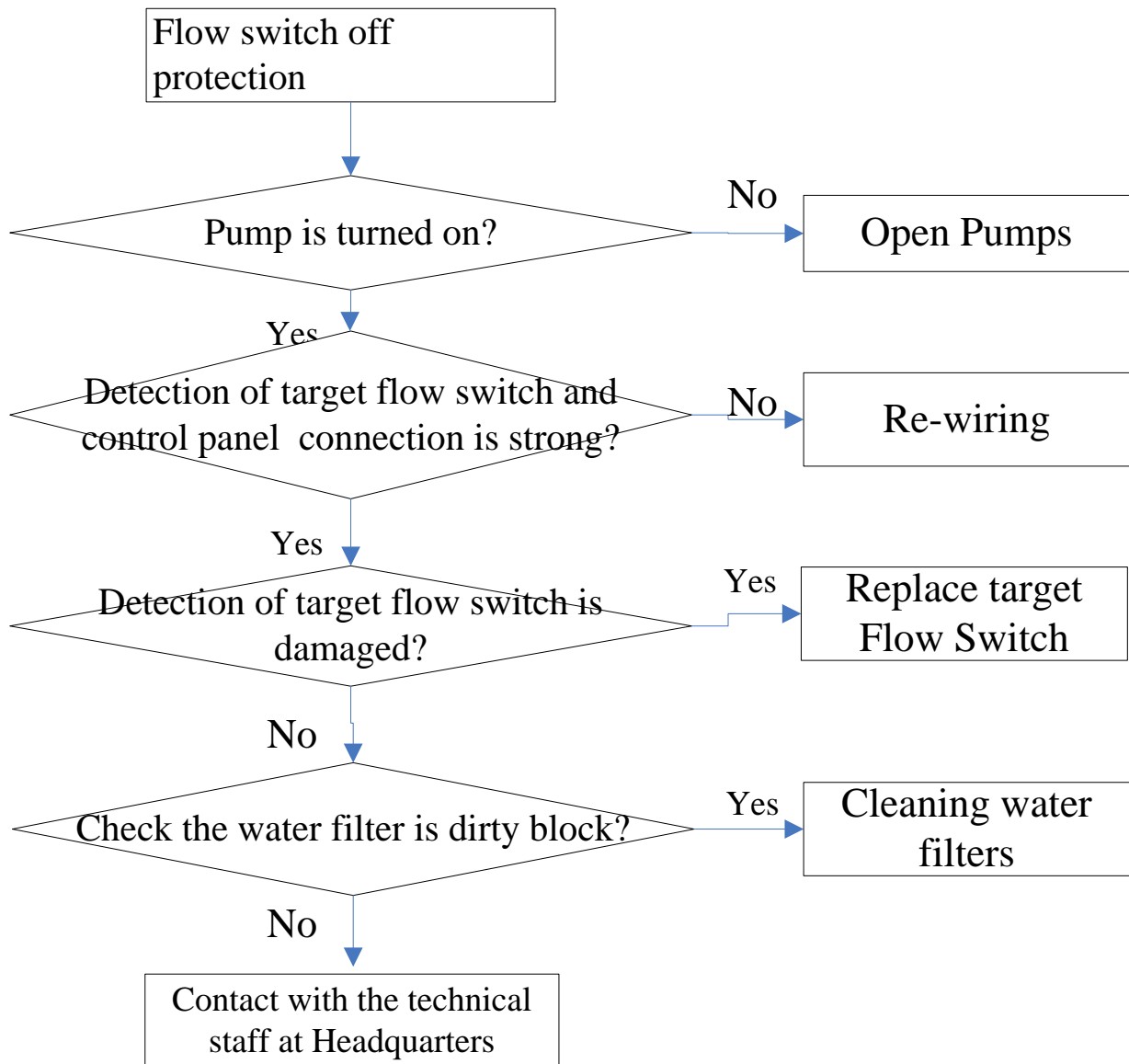

(N) Freezing point switch protection

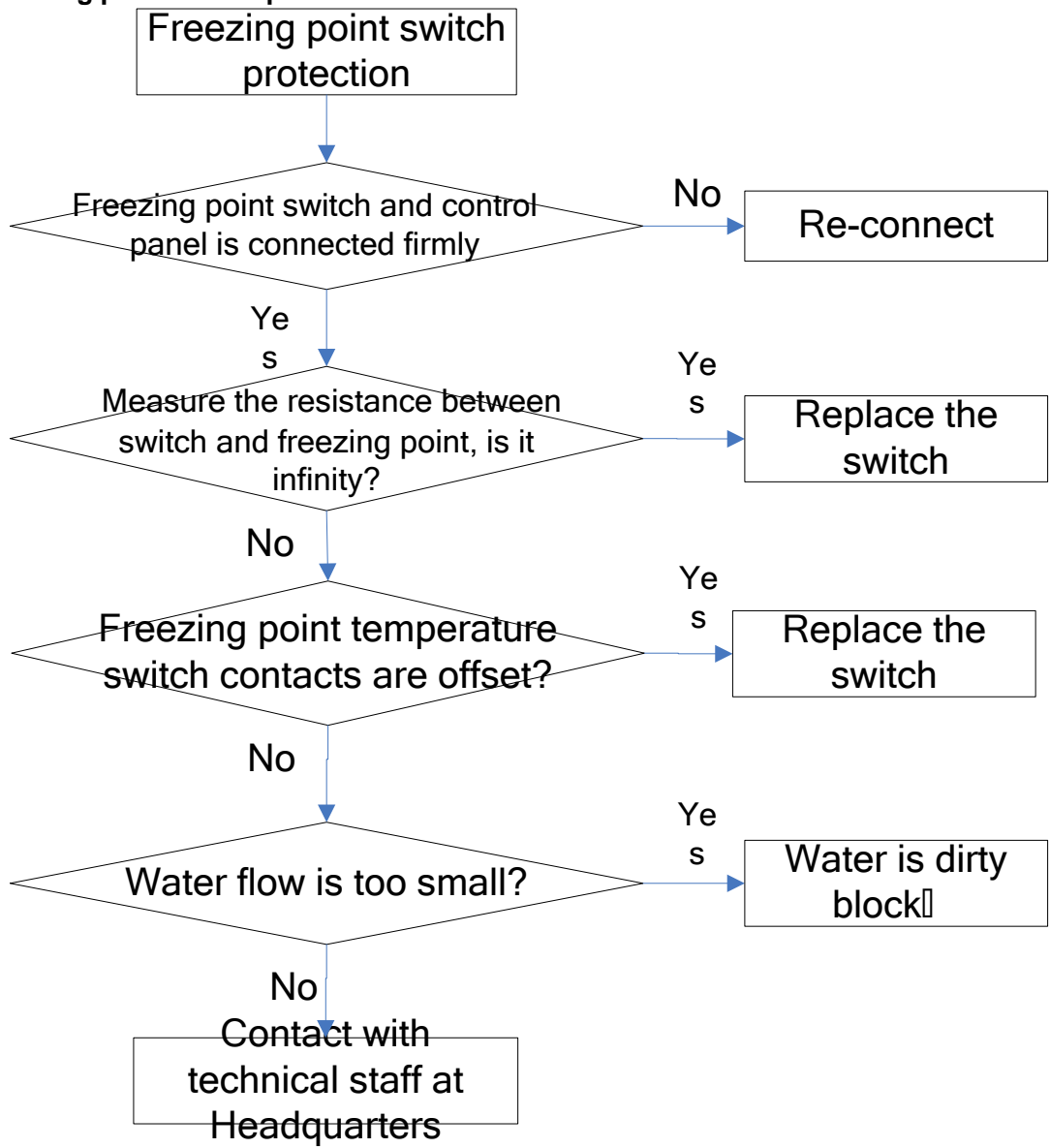

(O) Heating over-temperature protection

